

# 2

## Snap-Action Switches

Installation guide  
S800, S814, S820,  
S826/S926, S840,  
S847/S947, S850,  
S870/S970, S880

Manual SE-M.en

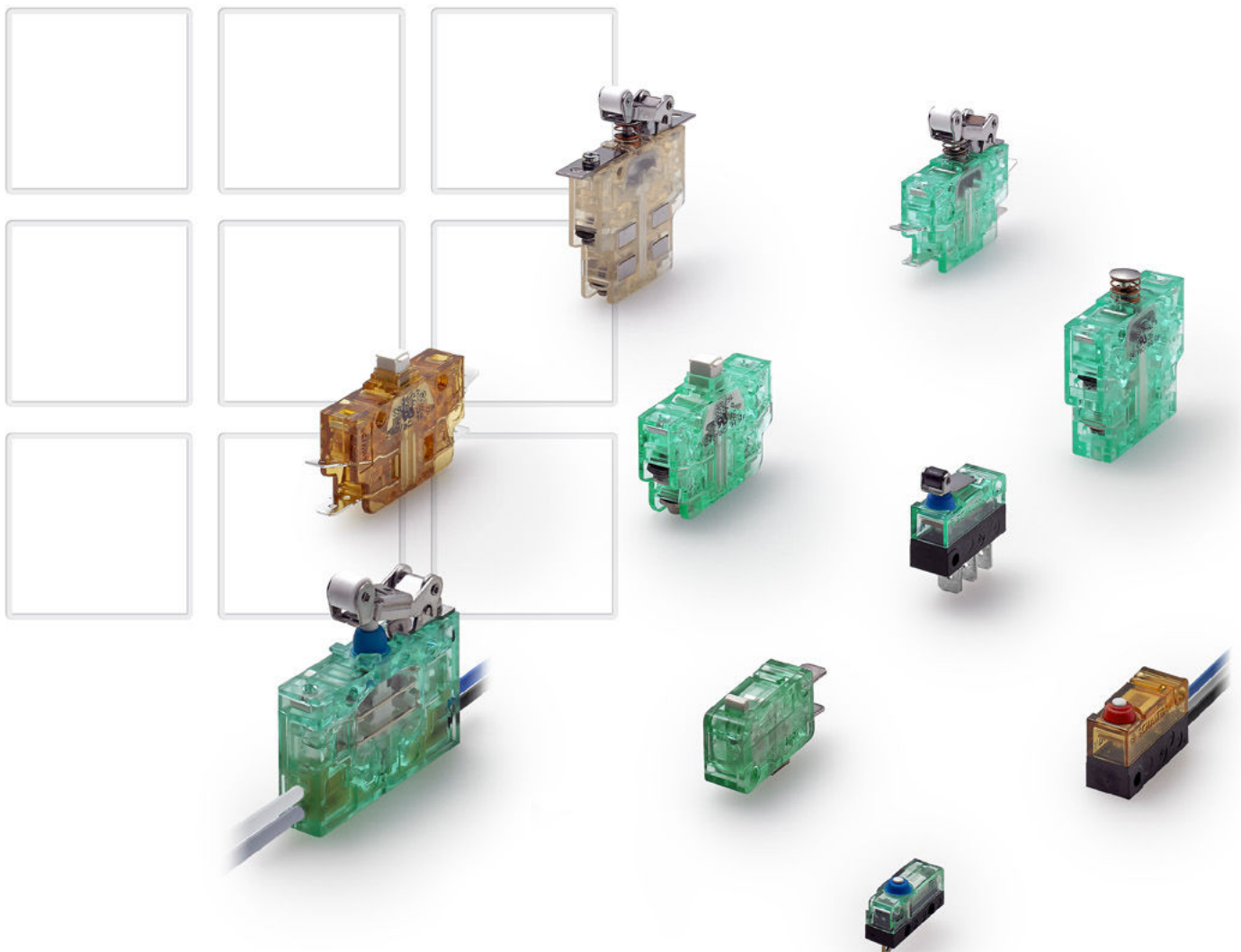

## Content

1	Types of assembly .....	5
1.1	Front mount S800/S820/S826/S926/S847/S947/S850.....	6
1.1.1	Front mount with mounting brackets .....	6
1.1.2	Front mount without mounting brackets .....	7
1.2	Lateral mount S800/S820/S826/S926/S847/S947/S850 .....	8
1.2.1	Collar screw - variant A.....	10
1.2.2	Threaded M4-bolt without collar - variant B .....	11
1.2.3	Duo clip or spring lock washer - variant C .....	12
1.3	Lateral Mounting of S870 / S970 / S880 .....	15
2	Terminals.....	16
2.1	Flat tab terminal S800/S826/S926/S847/S947/S870/S970 .....	16
2.2	Screw terminal S800/S826/S926/S847/S947/S850 .....	17
2.2.1	M3-screw with saddle clamp S800/S820/S826/S926/S847/S947/S850..	18
2.2.2	Screw Terminal M3 with mounting plate S870/S970 .....	20
2.2.3	M3-screw with spring washer S800/S820/S826/S926/S847/S947/S850	21
3	Mounting and Termination of S814 .....	22
4	Packet assembling S800/S820/S826/S926/S847/S947/S850 .....	23
4.1	Ganging via mounting brackets S800/S820/S826/S926/S847/S947/S850:....	25
5	Circuit board mounting S870/S970/S880: .....	26
5.1	S870 circuit board mounting.....	26
5.2	S880 circuit board mounting.....	28
6	Screw lock and marker .....	30
6.1	Screw lock adhesive .....	30
6.2	Sealing paint .....	30
6.3	Marker .....	30
7	Actuation of the roller lever	
	S800/S820/S826/S926/S847/S947/S850/S870/S970/S880 .....	31
7.1	Actuation S800/S820/S826/S926/S847/S947/S850 .....	32
7.2	Actuation S870 .....	33

---

7.3	Actuation S880 .....	34
8	Appendix .....	35
8.1	Schaltbau collar screw short version "BS-SK-K":.....	35
8.2	Schaltbau collar screw long version "BS-SK-L":.....	35



This symbol indicates possible danger.



This symbol indicates background information for the reader.

**This installation guide is valid for the switch series S800, S814, S820, S826/S926, S840, S847/S947, S850, S870/S970 and S880.**



### General advice:

- Snap action switches should only be mounted by qualified professional staff.
- Always determine the appropriate handling of the switch according to the specification, product catalogue and data sheet.
- Observe the required clearance and creepage current distances. This is also applicable for connected wires.
- It is necessary to use insulating plates when ganging or mounting switches on conductive surfaces. This is also recommended when placing several switches next to each other.
- In general, only screwdrivers with a torque indicator should be used. The specified tightening torques must not be exceeded.
- Inappropriate handling of switches, for example through
  - mechanical overload during installation and operation or
  - a hard impact or
  - the use of chemicals (among other things detergents, adhesives etc.) which are not compatible with the materials used,

may cause breakage, visible cracks and distortion. Because of this, the electrical insulation capacity of the housing or the insulation between the circuits could decrease.

---

## 1 TYPES OF ASSEMBLY



### Assembly advice:

- When mounting the switches make sure to use two fastening elements (e.g. screws) per switch.
- The switches can be mounted in any orientation.
- The surface on which the switch is mounted, must be level, clean and free of burr in order to reduce the mechanical stress on the switch housing.
- The switch must only be in contact with materials which are compatible with the housing material. This also applies for all surfaces on which the switch is mounted, as well as the fastening elements used, such as screws, nuts or similar. Furthermore, it must be taken into consideration that all chemicals used on or near the switches (e.g. detergents, adhesives, oil, grease...) are also compatible with the housing material. That is Polycarbonate (PC) for the S8XX-series and Polyetherimide (PEI) for the S9XX-series. See also chapter 6.
- All here mentioned tightening torques apply to screw threads that are free of grease and oil.
- **Caution:** It is not permissible to tighten the terminal screws without connecting a terminal lead

## 1.1 FRONT MOUNT S800/S820/S826/S926/S847/S947/S850

### 1.1.1 FRONT MOUNT WITH MOUNTING BRACKETS

- Both mounting surfaces (customer side) on which the switch is mounted, must lie in the same plain to prevent mechanical stress being induced into the switch housing.

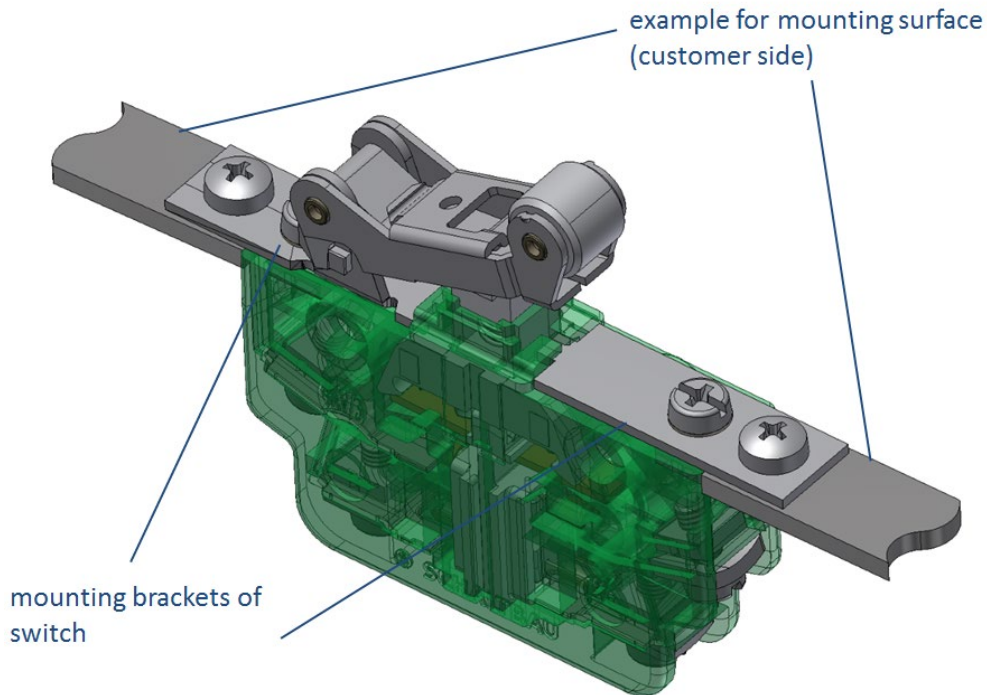

- The two mounting surface holes (customer side) must be adjusted to those of the switches mounting bracket holes.

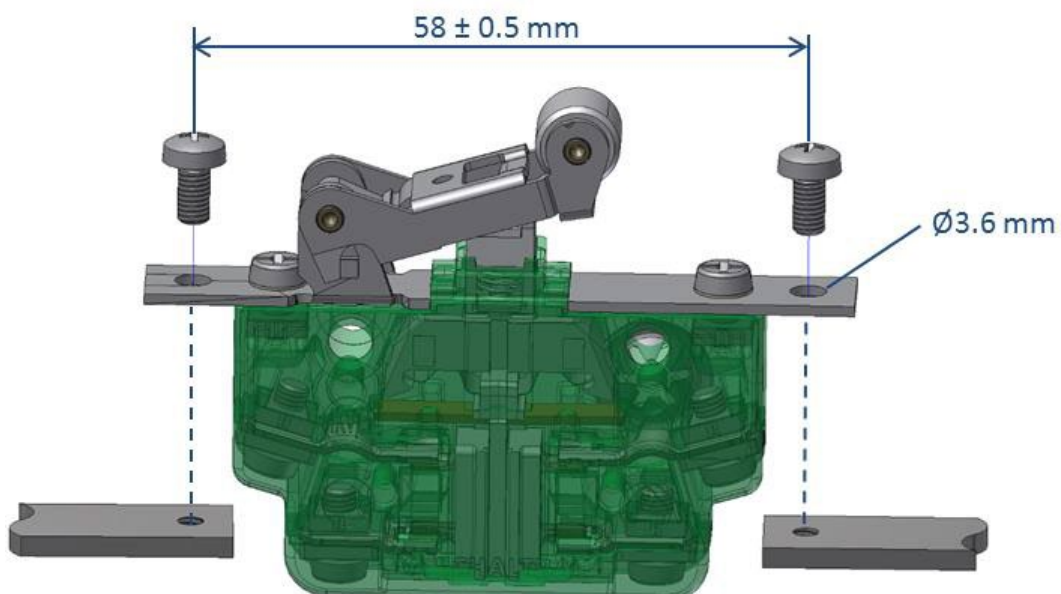

### 1.1.2 FRONT MOUNT WITHOUT MOUNTING BRACKETS

- In order to prevent damage to the housing of the switch, the maximum penetration depth of the screw, measured from the top surface of the housing to the end of the screw, must not exceed 5 mm.
- It is recommended to use either (zinc) galvanized screws or screws made from stainless steel.

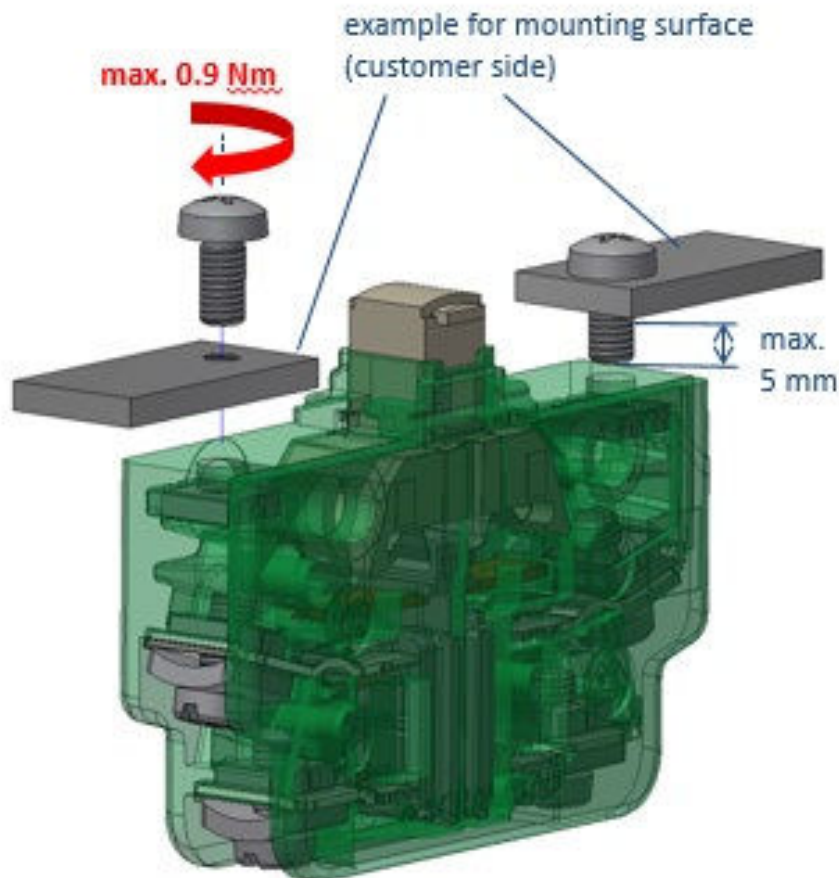



1.2 LATERAL MOUNT S800/S820/S826/S926/S847/S947/S850

Variant A: collar screw  $\varnothing 4$  mm with M3-thread (see appendix 8.1).

Variant B: M4-screw or M4-threaded bolt with nut and washer.

Variant C: bolt  $\varnothing 4$  mm combined with either duo clip or spring lock washer.

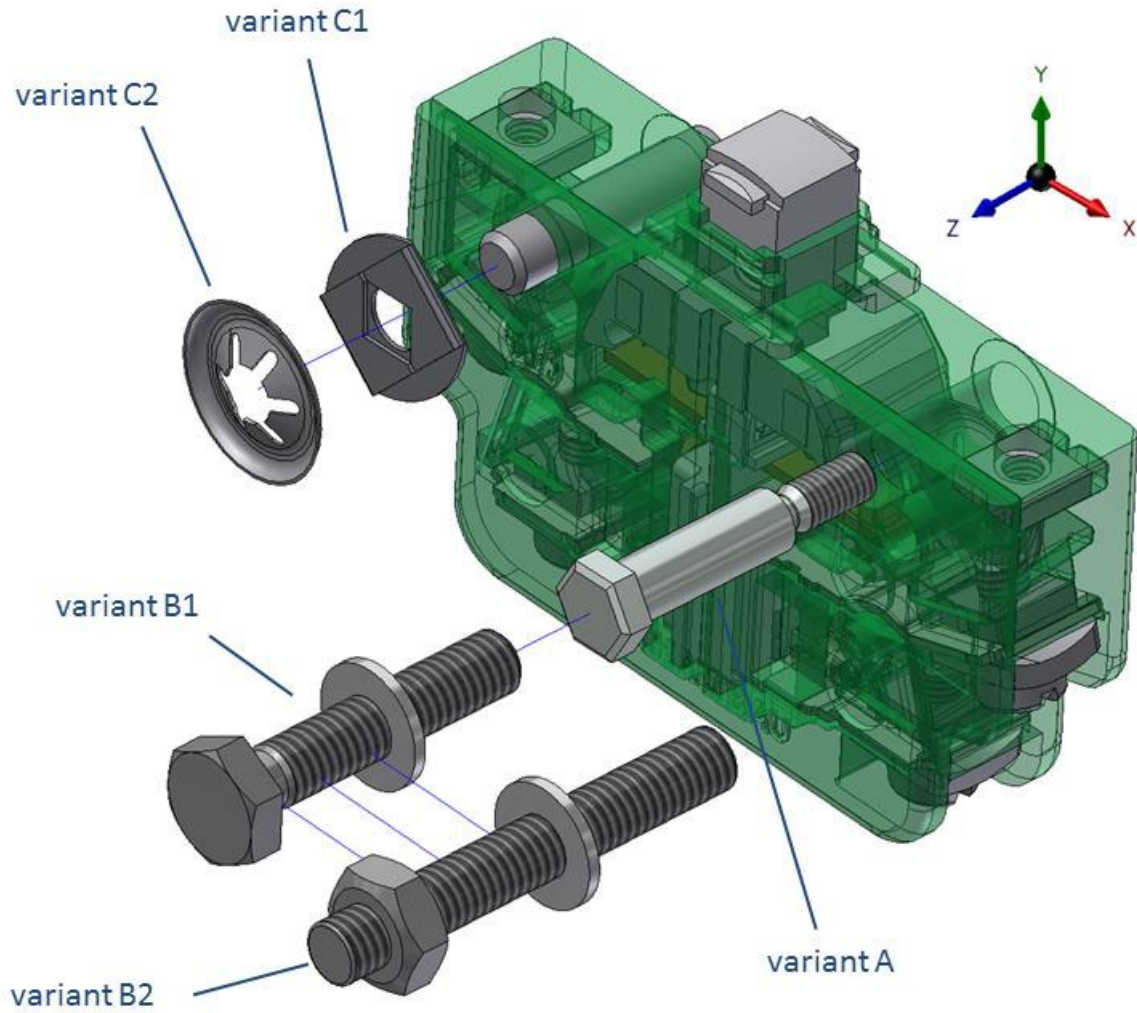
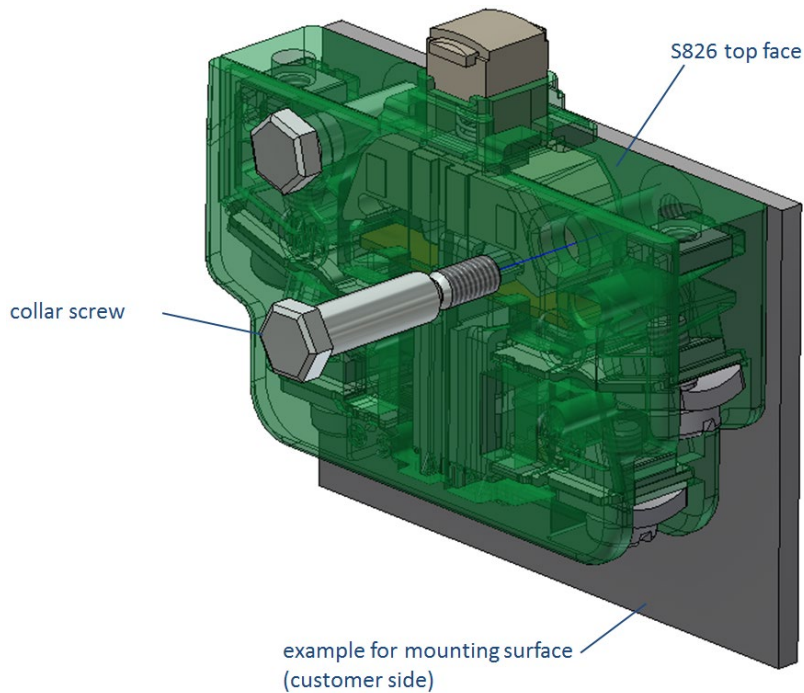



Table: Relative comparison of variants A-C, when mounted correctly:

	variant A	variant B	variant C
force on switch housing	does not exist	dependend on tightening torque	force transmission via spring
clearance in Z-direction	ca. 0.2 mm	no clearance	self-adjusting due to spring

### 1.2.1 COLLAR SCREW - VARIANT A



- Lateral mounting with a collar screw  $\varnothing 4$  mm with M3-thread (see appendix 8.1) has the advantage that, when correctly tightened, the housing of the switch cannot be mechanically overloaded. This is due to the protrusion of the screw collar, see diagram below.

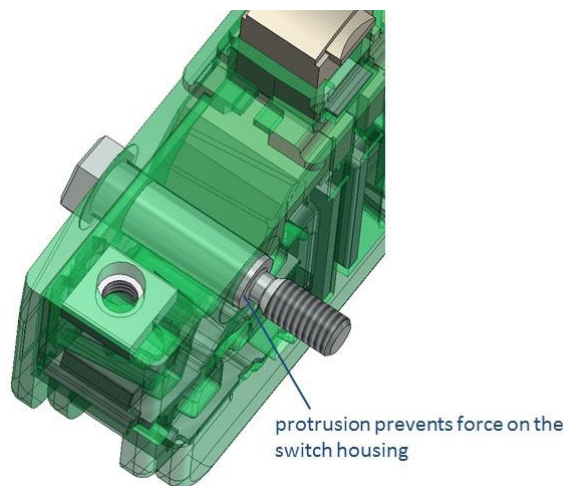

- The use of washers is not allowed, because this would apply a force to the switch housing and the advantage of the collar screw would be lost.
- The Schaltbau collar screw can be ordered under the article description “BS-SK-K” for one switch and “BS-SK-L” for use with two switches together.
- When using a roller lever on the switch, observe that the mounting surface is flush with the top surface of the switch. This prevents blocking of the roller lever.

### 1.2.2 THREADED M4-BOLT WITHOUT COLLAR - VARIANT B

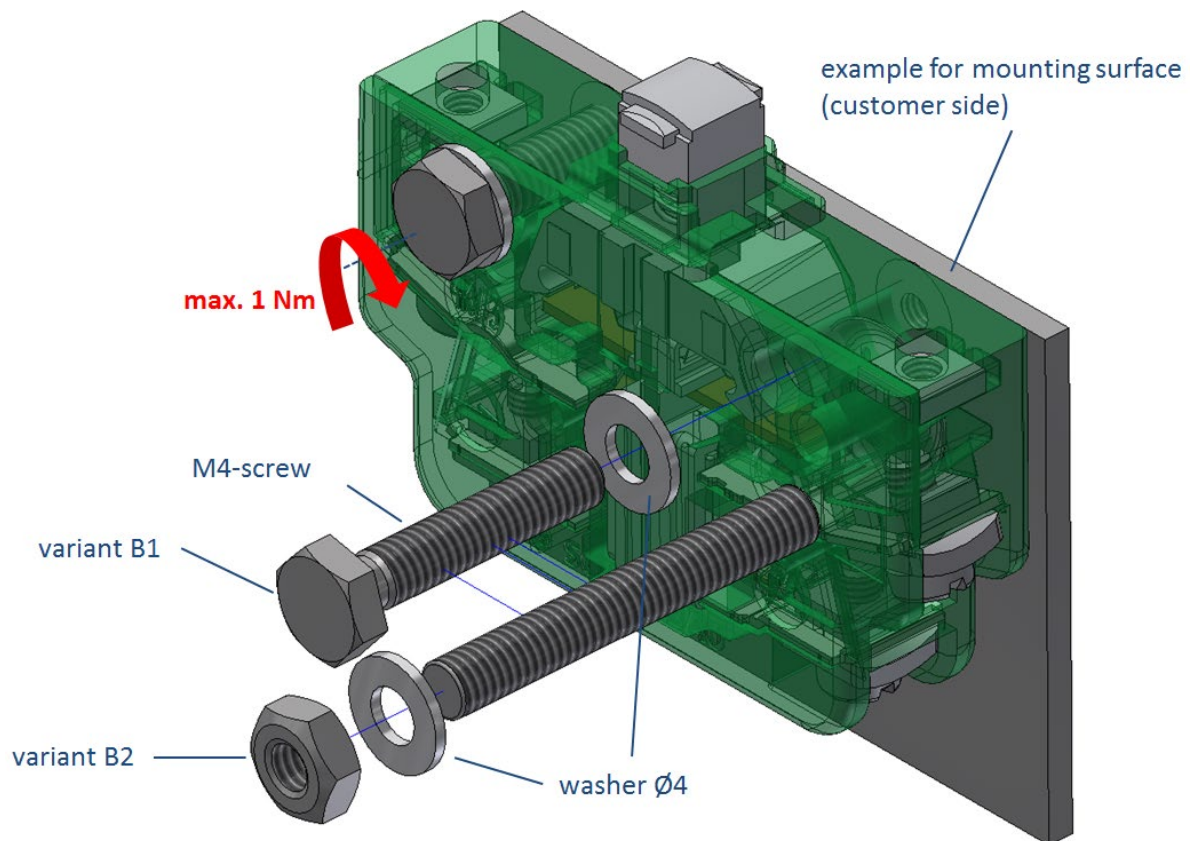

- It is recommended to use a screw or threaded bolt with M4-thread. This has the advantage that no misalignment can occur during operation.
- When using a roller lever on the switch, observe that the top surface is flush with the mounting surface. This results in a smooth actuation of the roller lever.
- The use of safety nuts with a polymer locking element is not allowed since this would result in a reduction of tightening force.



1.2.3 DUO CLIP OR SPRING LOCK WASHER - VARIANT C

**Functionality:**



Both the duo clip and the spring lock washer use the principle of wedging or self-locking, and both can only be moved in one direction when placed on the bolt since the other direction is locked. That is because the spring lock surfaces slide onto the bolt in one direction but they clamp on the bolt in the locked-direction and apply a spring force. There is no play when the spring lock washer is pushed against the switch housing.

**Duo clip (available from Schaltbau with the article description „DC4“):**

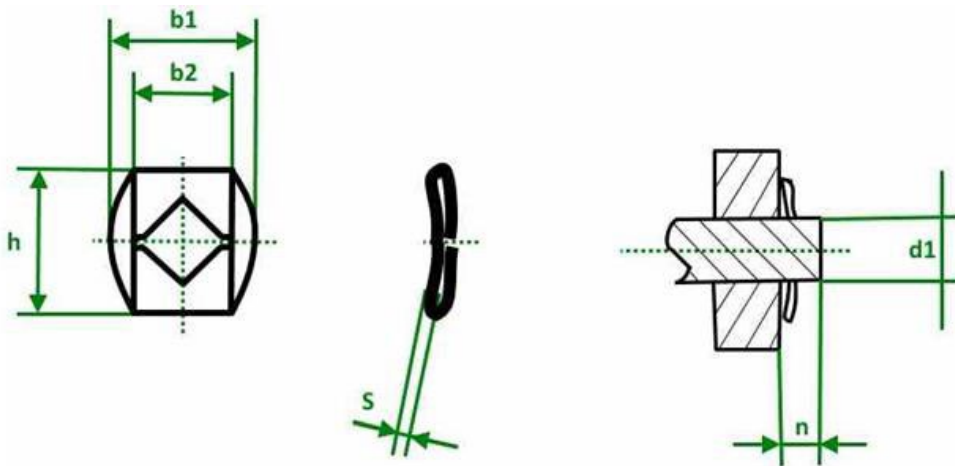

Duo clip	d1	b1	b2	h	s	n
	4.0 mm	9.3 mm	6.1 mm	10 mm	0.3 mm	>3.0 mm

**Spring lock washer:**

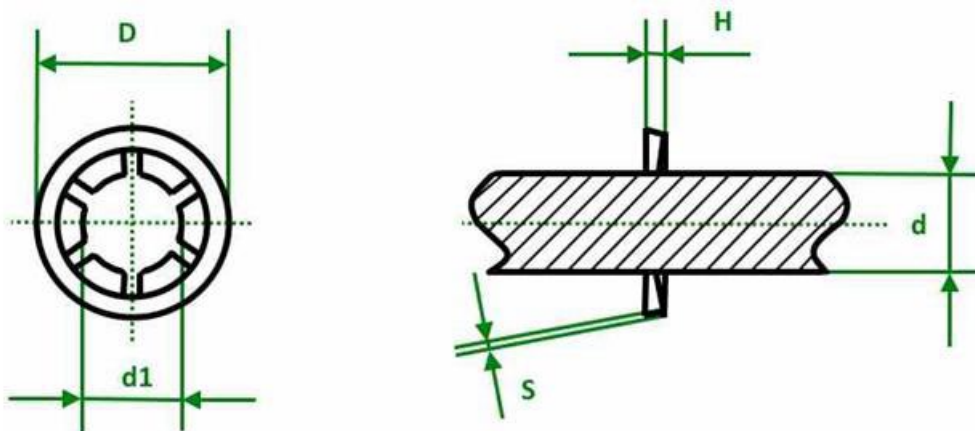

locker washer	d	D	d1	H	s	n
	4 mm	11.5 mm	3.7 mm	1.3 mm	0.2 mm	>1.0 mm

- A new duo clip or spring lock washer must be used for every mounting.
- The bolt ( $\varnothing 4$  mm) should be chamfered to make installation easier.
- Duo clips can be slid onto the bolt without a tool, but for the spring lock washer, a tool is necessary.
- Duo clips can be removed easier than spring lock washers. To do this, one of the clamping surfaces has to be bent open.
- Duo clips and spring lock washers must not be removed by applying a tool between these and the switch housing, since it would cause damage.

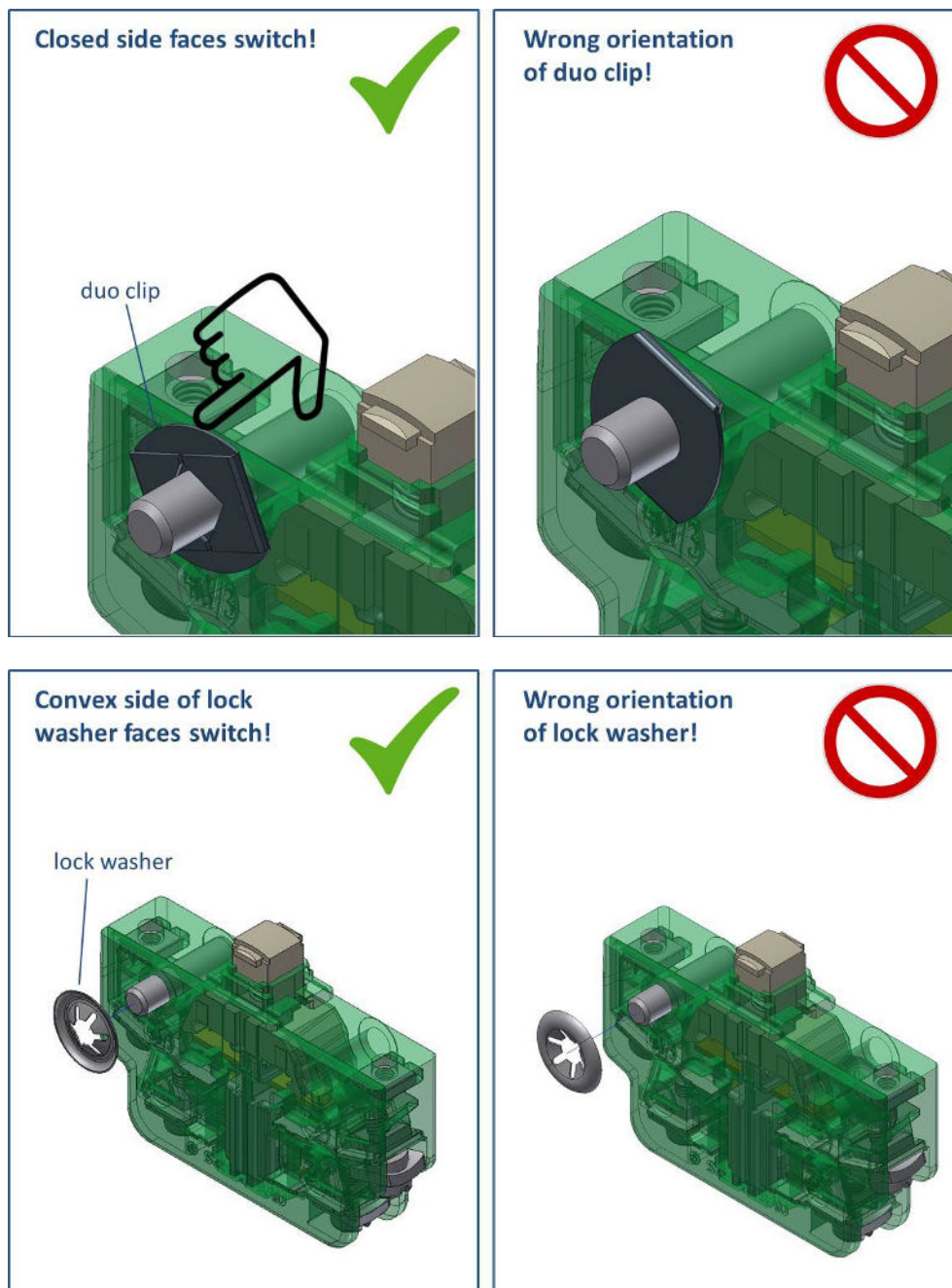



- Such a tool makes the installation of the spring lock washer much easier and quicker, especially when difficult to access.
- Assembly is done in the axial direction of the bolt.



### 1.3 LATERAL MOUNTING OF S870 / S970 / S880

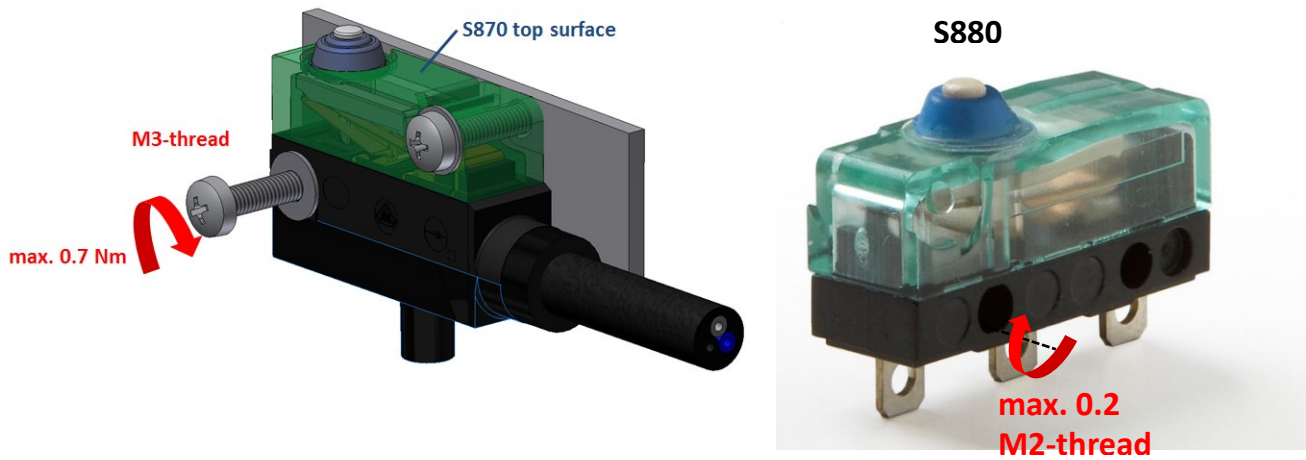

- All advice is valid for the S870, S970 und S880 unless specifically mentioned.
- When using a roller lever on the switch, observe that the top surface is flush with the mounting surface. This results in a smooth actuation of the roller lever.
- The use of safety nuts with a polymer locking element is not allowed since this would result in a reduction of tightening force.





## 2 TERMINALS



### Terminal advice:

- The insulation of the wire and the terminal should be abutting.
- Prevent load transmission onto the switch terminals, and ensure that connected wires have sufficient strain relief.
- When using versions with blowout magnets observe the correct polarity, see the plus/minus symbol on the switch or data sheet.
- The terminals must be secured against automatic loosening by a force-fit and form-fit connection.

### 2.1 FLAT TAB TERMINAL S800/S826/S926/S847/S947/S870/S970

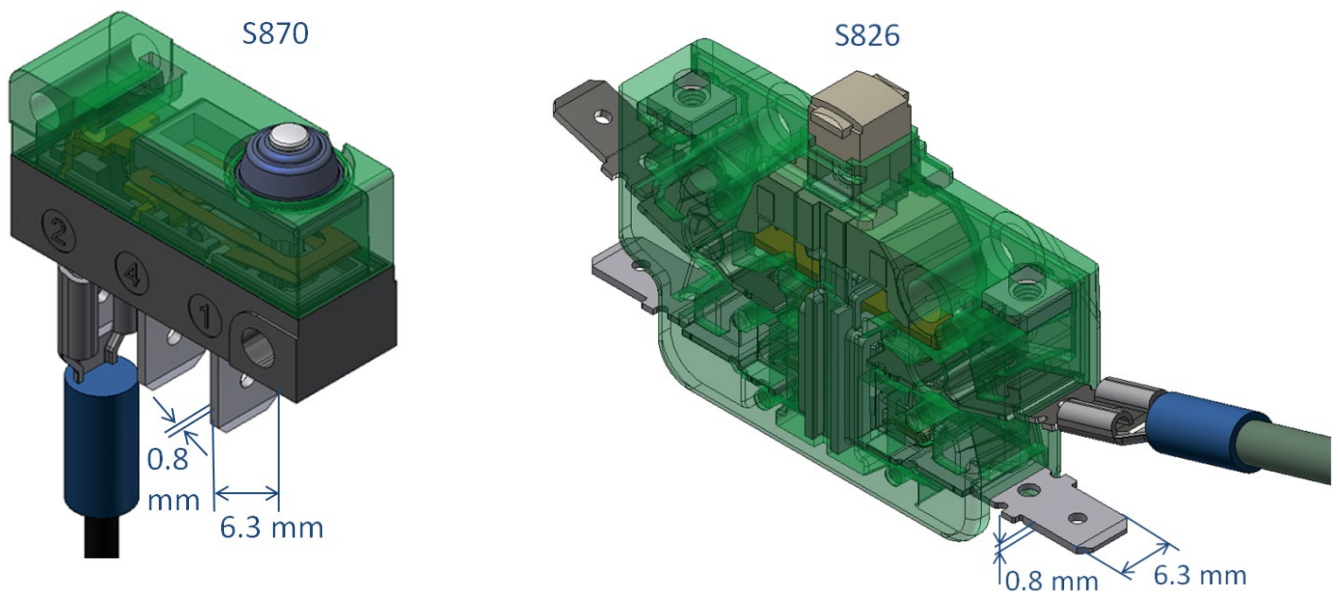

- Flat tab connections should not be plugged-in more than once.
- Flat tabs and their corresponding push-on receptacles must not be bent or twisted.
- Flat tabs and their corresponding push-on receptacles must be clean and free of particles before installation.
- Flat tabs and their corresponding push-on receptacles must not be greased, because that would impinge on both contact resistance and mating retention forces.
- Suitable push-on receptacles: 6.3 mm x 0.8 mm

## 2.2 SCREW TERMINAL S800/S826/S926/S847/S947/S850

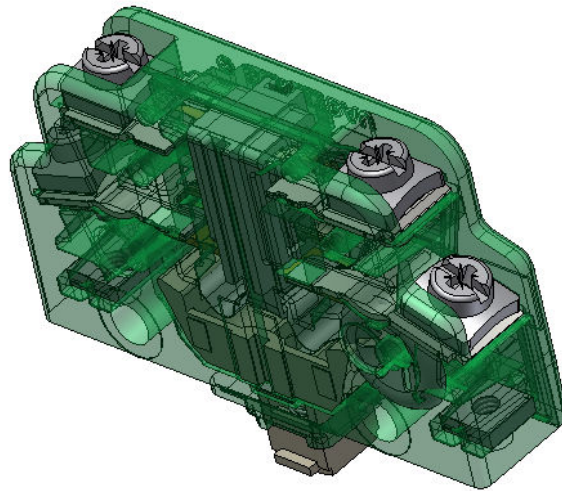

- **Caution:** It is not permissible to tighten the terminal screws without connecting a terminal lead
- When using customer screws, the length of the screw has to be considered. The end of the screw is not allowed to push against the inner switch housing. As seen in the figure below, the maximum distance between the top surface of the terminal and the end of the screw must be smaller than 5.4 mm. This refers to all of the above mentioned switches.

S800/S826/S926/S850

S847/S947

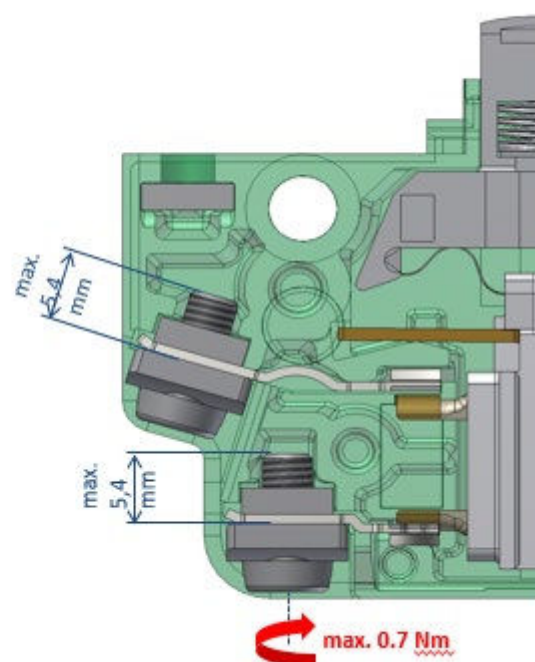
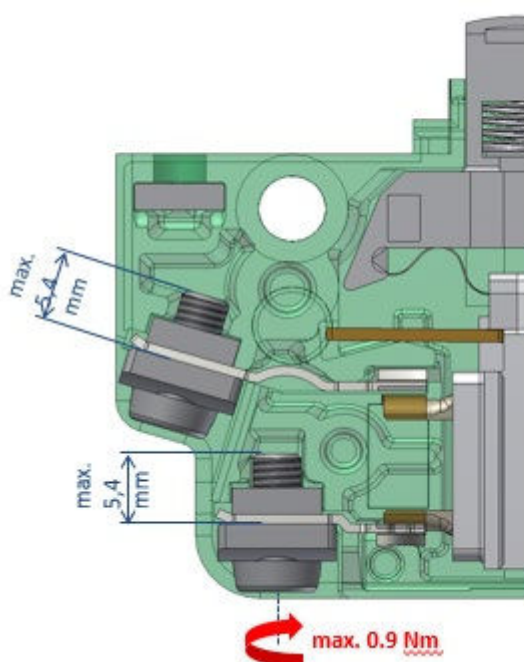

- Maximum tightening torque of the terminal screw: 0.9 Nm.  
0.7 Nm (S847 / S947)
- **Caution:** It is not permissible to tighten the terminal screws without connecting a terminal lead
- It is recommended to use the screw seen below from Schaltbau, which can be ordered with the article description „AS-KKA“.



#### 2.2.1 M3-SCREW WITH SADDLE CLAMP S800/S820/S826/S926/S847/S947/S850

- The wire insulation must be stripped back 8-9 mm.
- When using multi-core wires, end ferrules should be used. The maximum cable cross-section for these is 1.5 mm<sup>2</sup>.
- When using single-core wires, the maximum cable cross-section is 0.75 mm<sup>2</sup> to 2.5 mm<sup>2</sup> without end ferrules.

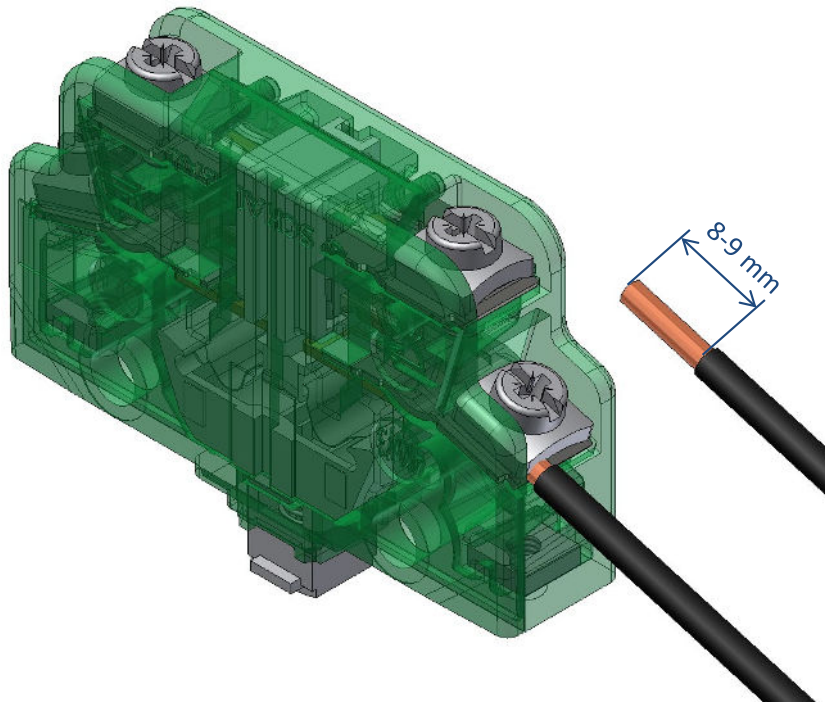

### 2.2.2 SCREW TERMINAL M3 WITH MOUNTING PLATE S870/S970

- The insulation of the leads and cable is according to 2.2.1.

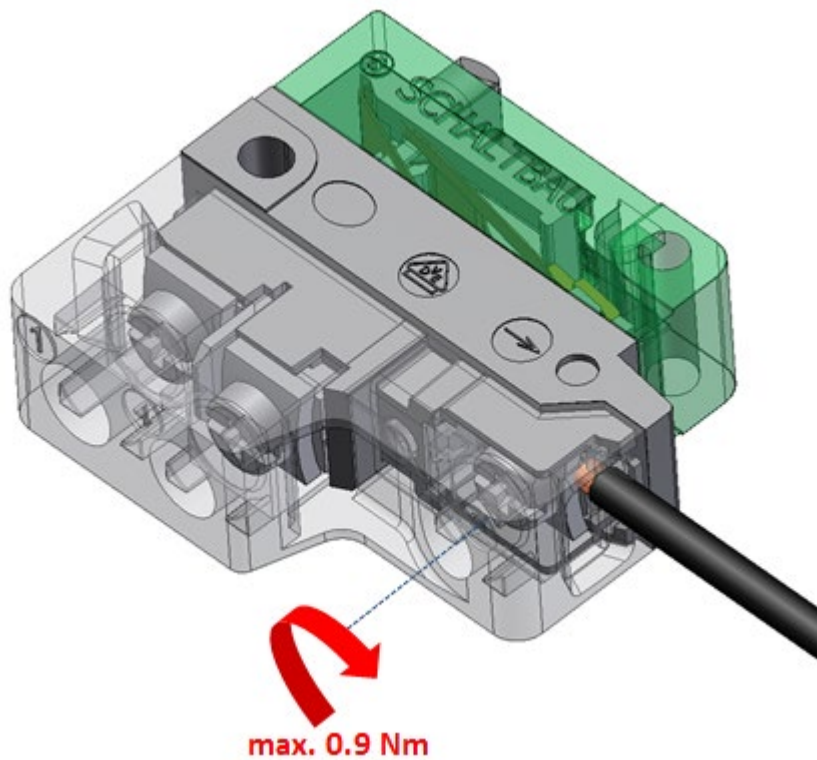

### 2.2.3 M3-SCREW WITH SPRING WASHER S800/S820/S826/S926/S847/S947/S850

- **Caution:** It is not permissible to tighten the terminal screws without connecting a terminal lead
- When using screws without a saddle clamp, it is only allowed to mount them with cable shoes or ring connections.
- A screw lock, e.g. a fan-shaped washer, should be used.

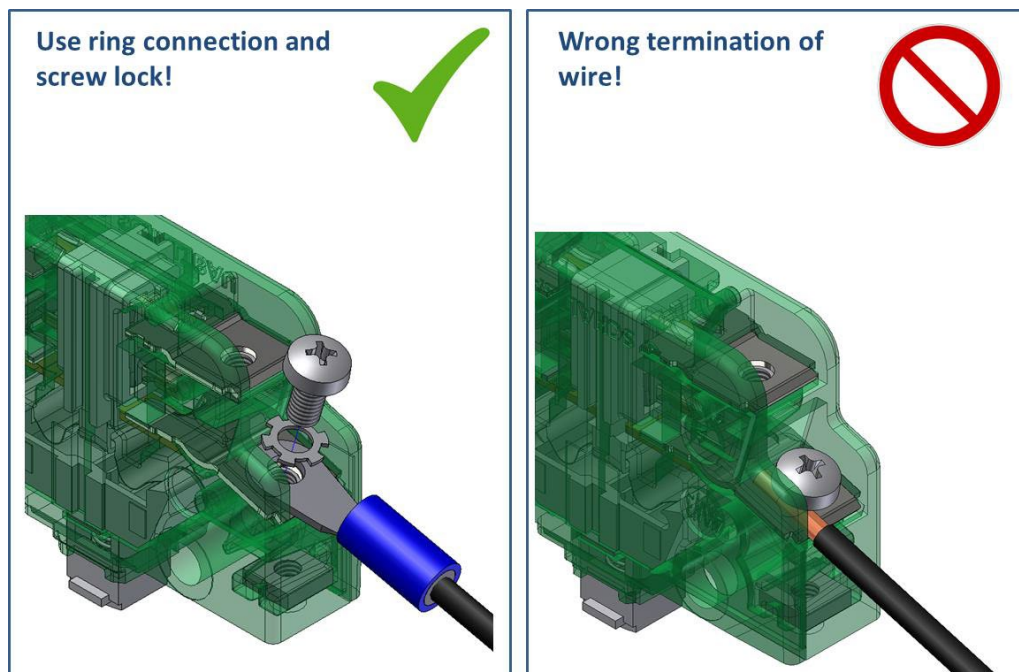



### 3 MOUNTING AND TERMINATION OF S814



#### Advice:

- **Caution:** It is not permissible to tighten the terminal screws without connecting a terminal lead
- In general all advice from chapters 1.2 und 2 is also valid.
- The maximum tightening torque must not exceed 1.0 Nm.

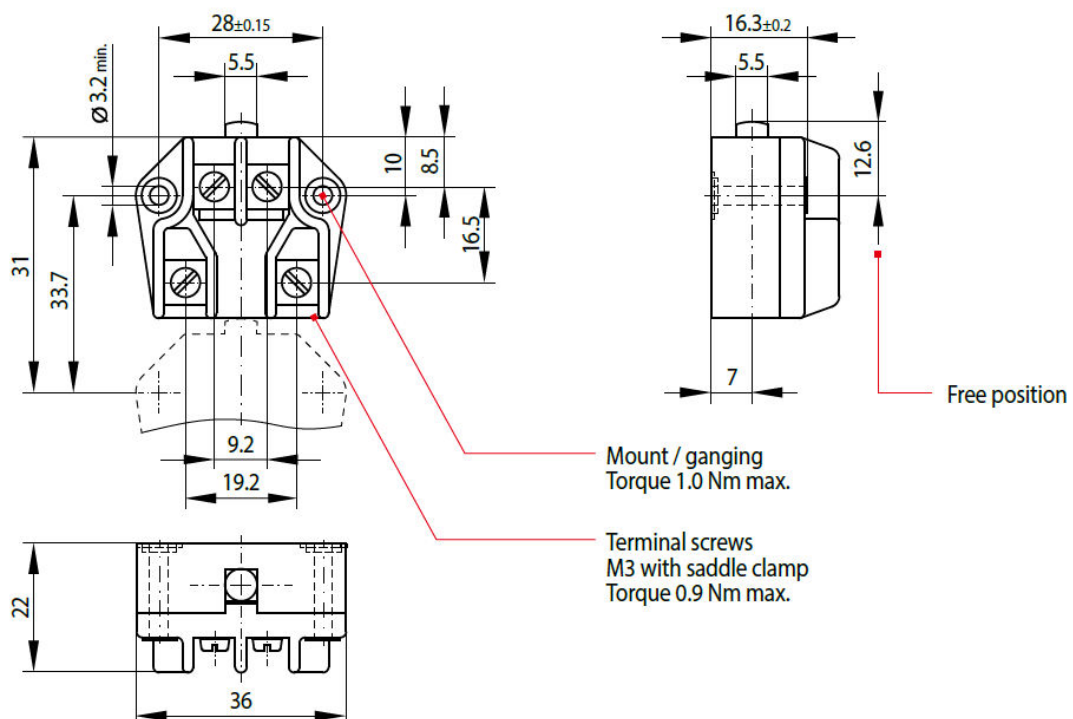
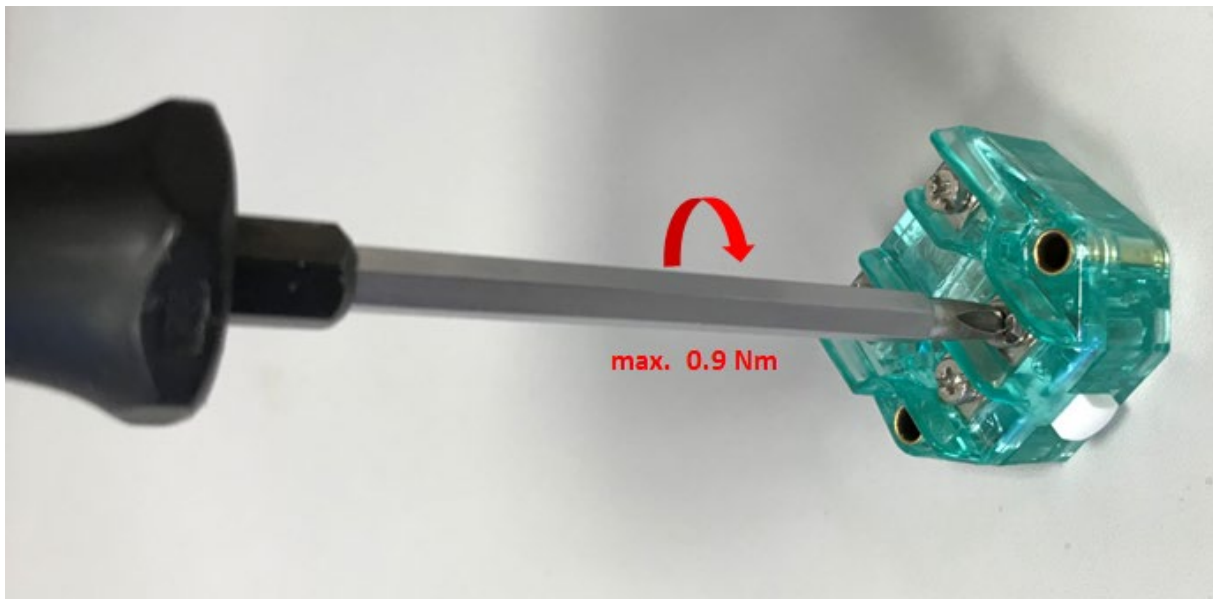



## 4 PACKET ASSEMBLING

### S800/S820/S826/S926/S847/S947/S850



Packet assembling can be either the ganging of several switches via the mounting brackets or via the lateral mounting holes of the switches.



#### Packet assembling advice:

- When ganging several switches, it must be taken into account that the fixing elements need to have a certain robustness to ensure an equal actuator travel.
- Stability can be considerably increased by using a fixation on both ends of the mounting rod or mounting frame.
- When ganging switches next to each other, it is recommended to place an insulation foil or insulation plate between them.

#### Example for ganging S826 via the mounting holes:

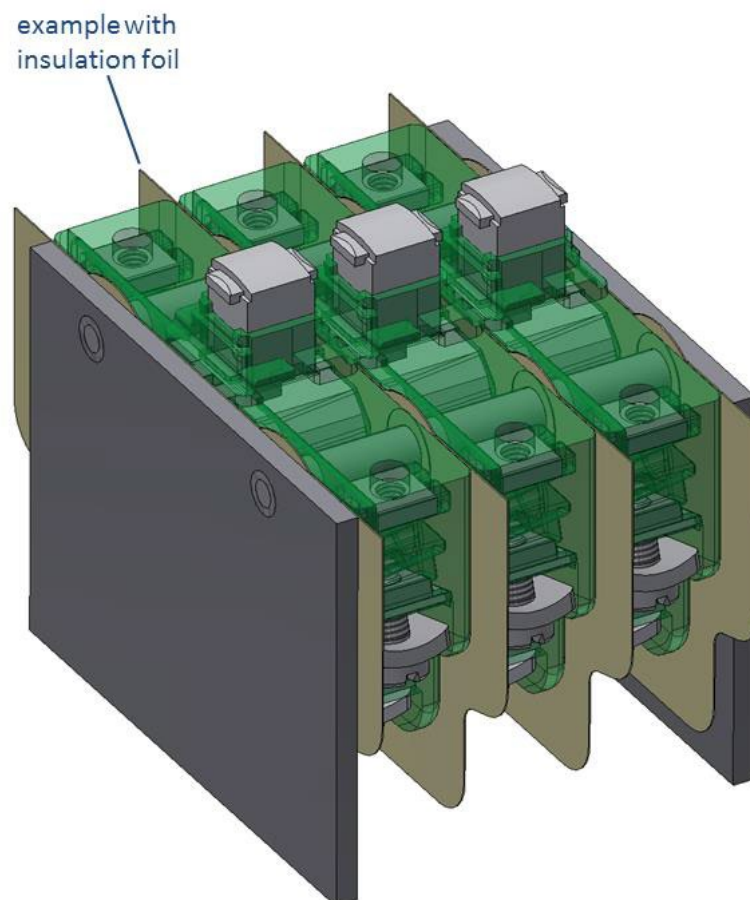

Example of ganging S870 via the mounting holes:

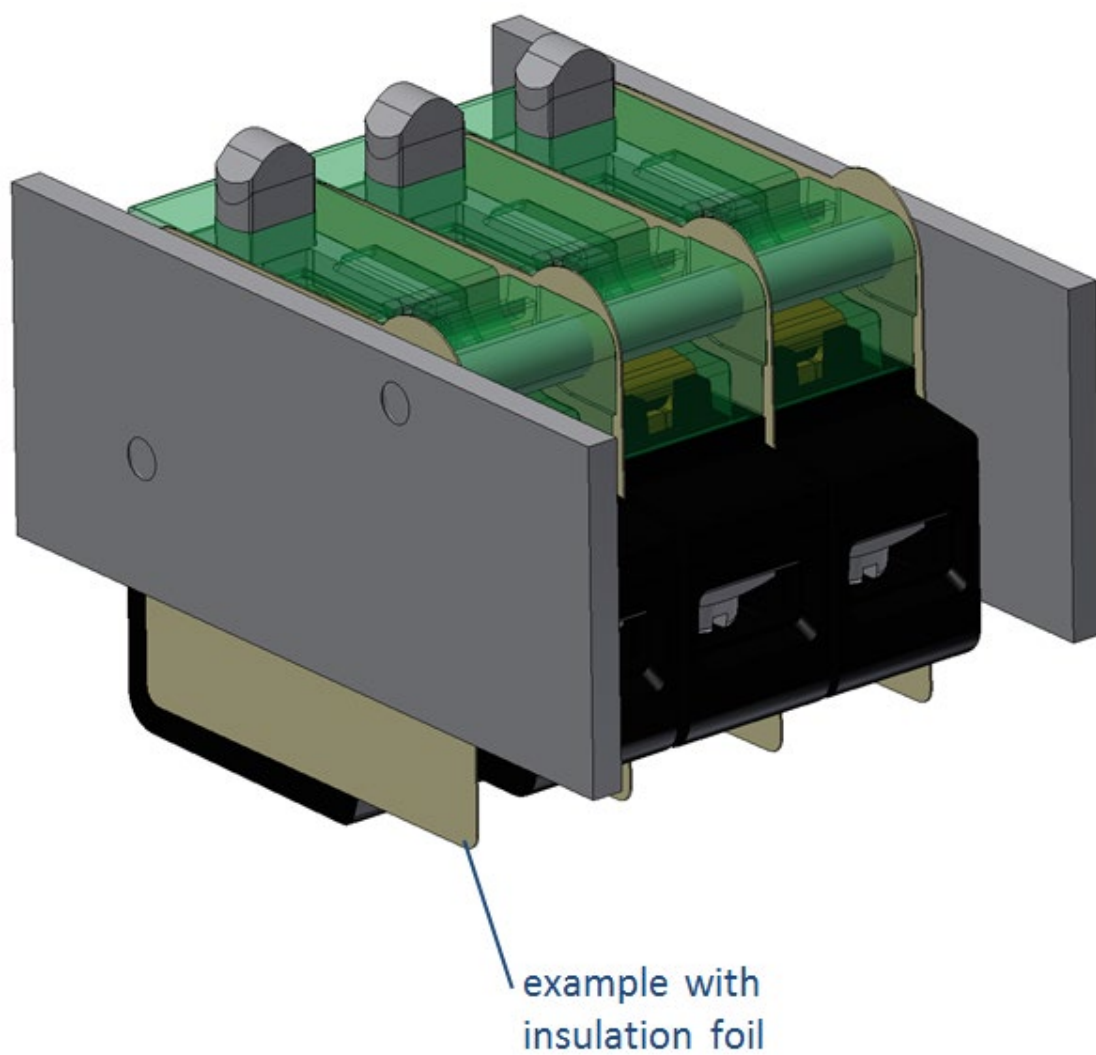

#### 4.1 GANGING VIA MOUNTING BRACKETS S800/S820/S826/S926/S847/S947/S850:

- Each switch must be installed according to chapter 1.2.1.

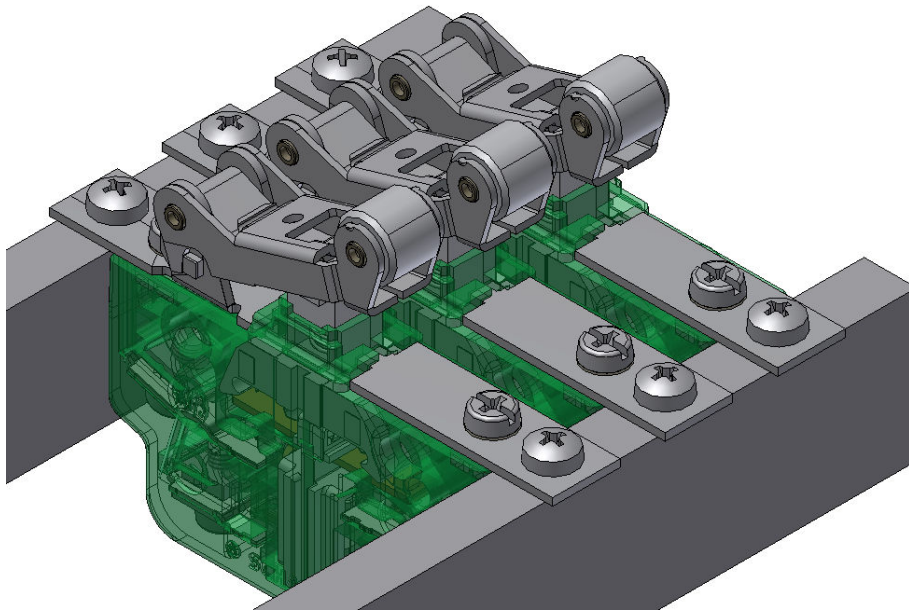

If two circuits are to be switched at once, Schaltbau provides a double switch with a double roller lever for the series S800, S826, S926, S847, S947. To mount two switches, Schaltbau offers a long version of the collar screw that can be ordered with the article description “BS-SK-L”, see appendix 8.2.

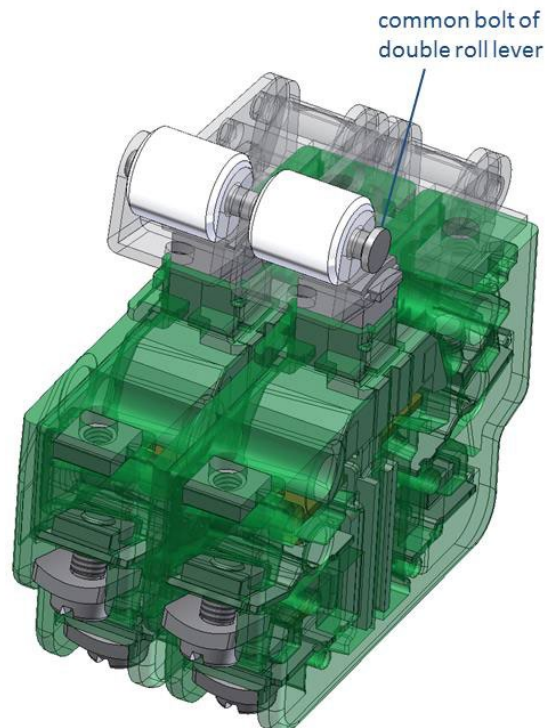

## 5 CIRCUIT BOARD MOUNTING S870/S970/S880:



### Circuit board mounting advice:

For reasons of health and environmental pollution, only lead-free solder\* should be used.

### 5.1 S870 CIRCUIT BOARD MOUNTING

- **Hand soldering:** A hand-held soldering iron with lead-free flux-filled solder wire should be used. Temperature: 400°C, Duration: max. 5 s.
- **Selective soldering:** A lead-free solder for selective soldering should be used. Temp.: 300°C, duration: max. 2.5 s, wave distance: 3 mm.
- **Wave soldering:** A wave soldering station with one Wörthmann Wave and lead-free solder should be used. Temperature: 260°C, duration: 5 s, width of wave: 66 mm; speed: 0.8 m/min, preheating: ca. 113 s at 110-145°C.

### PCB terminals, straight, style F:

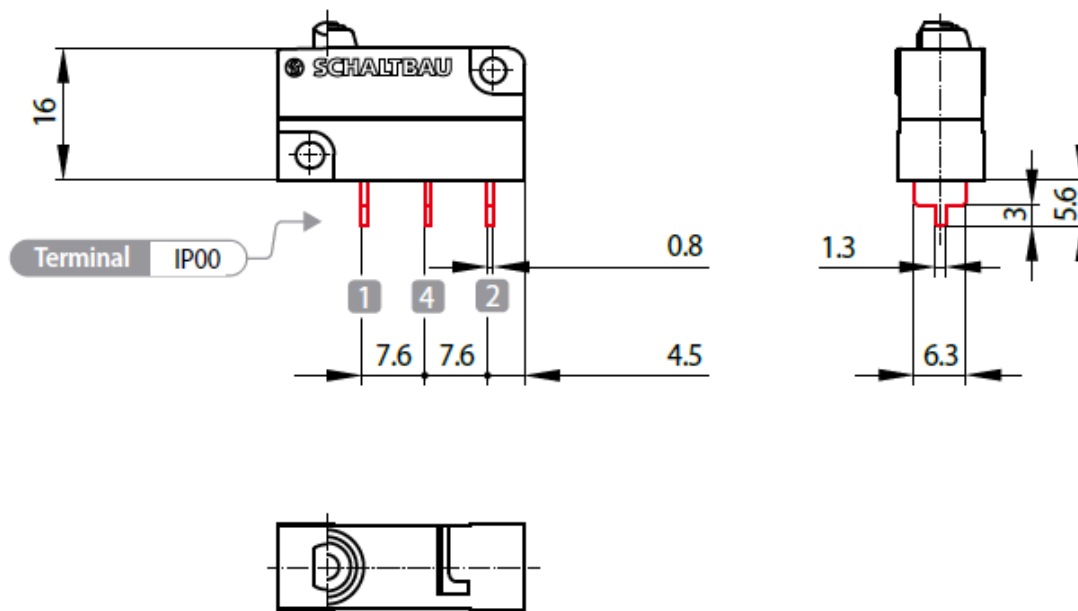

\*Advice regarding leaded solder is provided on enquiry!

## Solder lugs, straight, style G

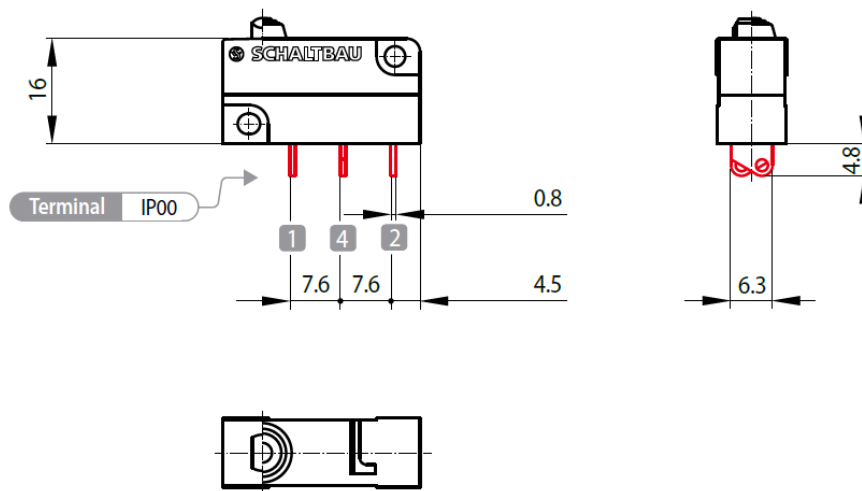

## 5.2 S880 CIRCUIT BOARD MOUNTING

### PCB terminals, straight, style F:

- **Hand soldering:** A hand-held soldering iron with lead-free flux-filled solder wire should be used. Temperature: 350°C, Duration: max. 3 s.
- **Selective soldering:** A lead-free solder for selective soldering should be used. Temp.: 300°C, duration: max. 1.5 s, wave distance: 3 mm.
- **Wave soldering:** A wave soldering station with one Wörthmann Wave and lead-free solder should be used. Temperature: 260°C, duration: 3 s, width of wave: 66 mm; speed: 1.3 m/min, preheating: ca. 70 s at 110-130°C.

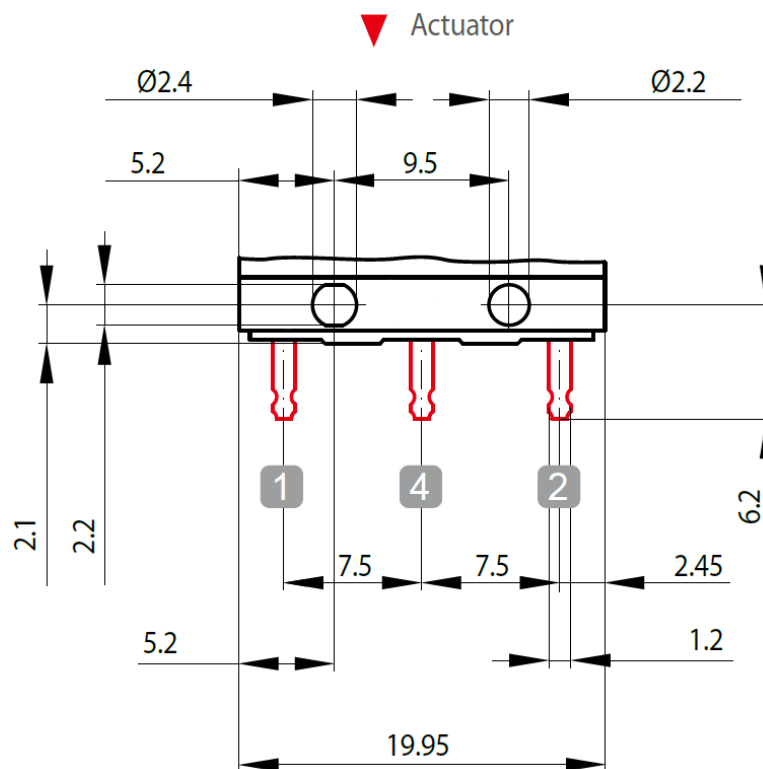

### Solder terminals, straight, style G:

- **Hand soldering:** A hand-held soldering iron with lead-free flux-filled solder wire should be used. Temperature: 370°C, Duration: max. 2 s.

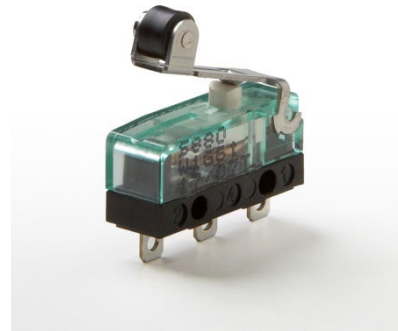
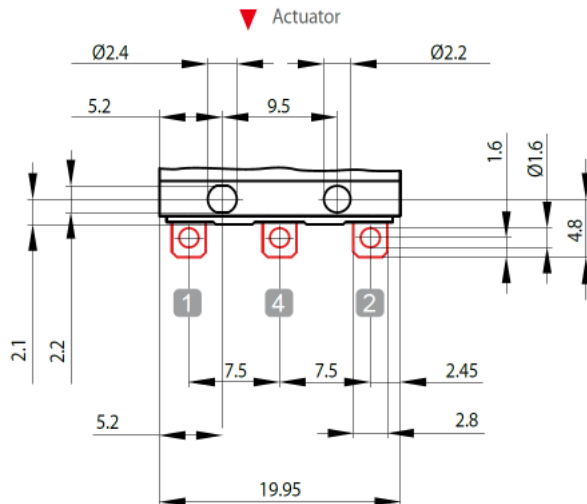

### PCB terminals, 90° LH-side(J), RH-side(P) with tilted pins (T):

- **Hand soldering:** A hand-held soldering iron with lead-free flux-filled solder wire should be used. Temperature: 350°C, Duration: max. 4 s.
- **Selective soldering:** A lead-free solder for selective soldering should be used. Temp.: 300°C, duration: max. 1.5 s, wave distance: 3 mm.
- **Wave soldering:** A wave soldering station with one Wörthmann Wave and lead-free solder should be used. Temperature: 260°C, duration: 3 s, width of wave: 66 mm; speed: 1.3 m/min, preheating: ca. 70 s at 110-130°C.

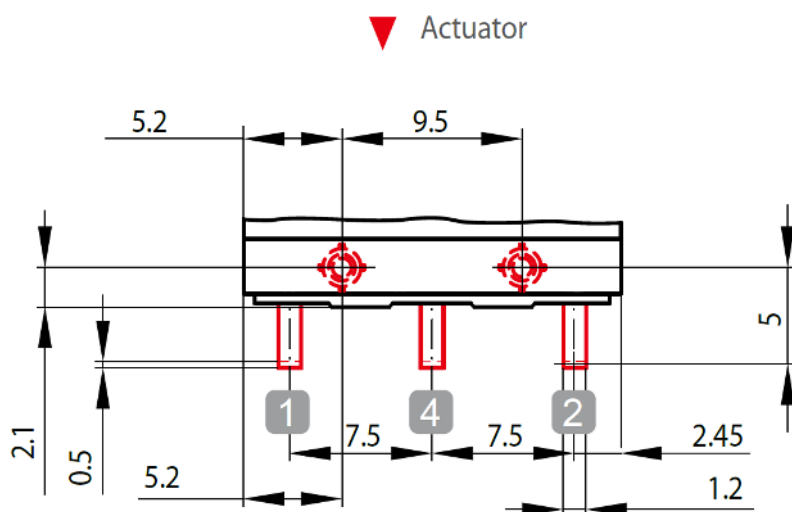



## 6 SCREW LOCK AND MARKER

The following terms are defined:



- **Screw lock adhesive** should prevent an unwanted and automatic loosening of the screw or nut, respectively.
- **Sealing paint** should indicate an unauthorized opening of the screw or nut, respectively.
- **Marker** can be used to mark a certain position of two parts and thus indicate a change in position, e.g. the angle of a mounted screw.

The following compatible products are recommended for PC (S8XX-series) and PEI (S9XX-series).

### 6.1 SCREW LOCK ADHESIVE

The screw lock adhesive from Three Bond with the article description TB1401 is recommended. The available colours are transparent, green and red.

### 6.2 SEALING PAINT

Sealing paint from PPG Industries with the article description ALO811003CE is recommended. The available colour is red.

### 6.3 MARKER

The marker from Zhi Pai with the article description ZP610, as well as the marker by Zebra with the article description 200M is recommended.



#### **Screw lock advice:**

The compatibility of the above mentioned paint, adhesive and marker with the plastic housing of the switch cannot be guaranteed by Schaltbau, because the manufacturer may change the content without notice. Therefore the applied paint, adhesive and marker should be re-verified by the customer before use.

## 7 ACTUATION OF THE ROLLER LEVER S800/S820/S826/S926/S847/S947/S850/S870/S970/S880



### Actuation advice:

- A roller lever is required if the direction of actuation deviates more than 15° from the plunger axis.
- The actuator should not be pre-tensioned when in the free position.
- For reliable operation, the actuator should travel for at least 50% of the pre-defined travel from „operating position“ to “total travel position”, see catalogue.
- For reliable operation including the positive opening function, the actuator must reach “total positive opening travel”, see catalogue.
- The actuation of the switch must not exceed the “total travel position”, see catalogue.
- High-impact actuation of the switch can have a negative effect on its mechanical life.
- The maximum actuating speed, specified in the catalogue, must not be exceeded.
- The roller lever must not be actuated laterally. Lateral force  $\vec{F}$  on the roll lever may cause damage.
- There must not be located oil or grease between the roll of the roller lever and the linear cam actuator or disk actuator, respectively.

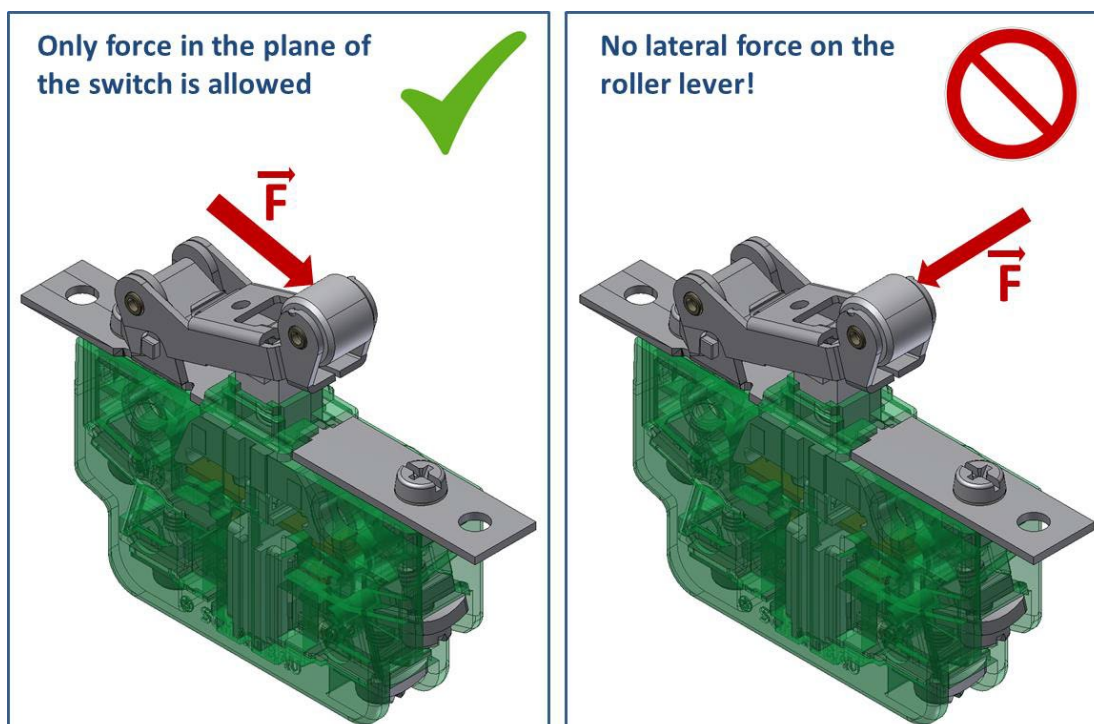

7.1 ACTUATION S800/S820/S826/S926/S847/S947/S850

- The flank angle of the linear cam actuator must be  $\geq 40^\circ$ .
- The width of the actuator should exceed the width of the roller.
- The surface of the actuator should be as smooth as possible.

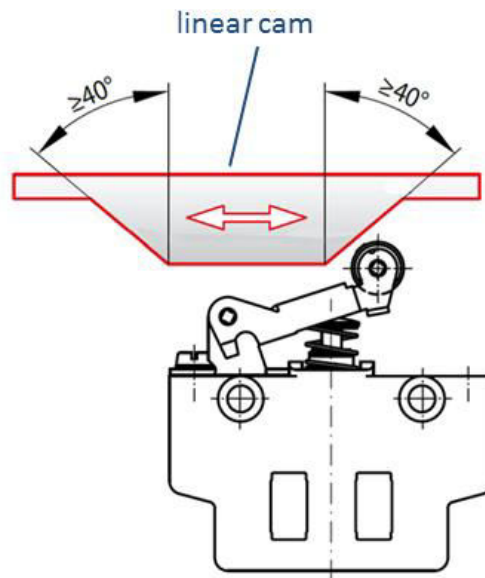

- Disks made from aluminum should not be used.
- The width of the actuator should exceed the width of the roller.
- The surface of the actuator should be as smooth as possible.

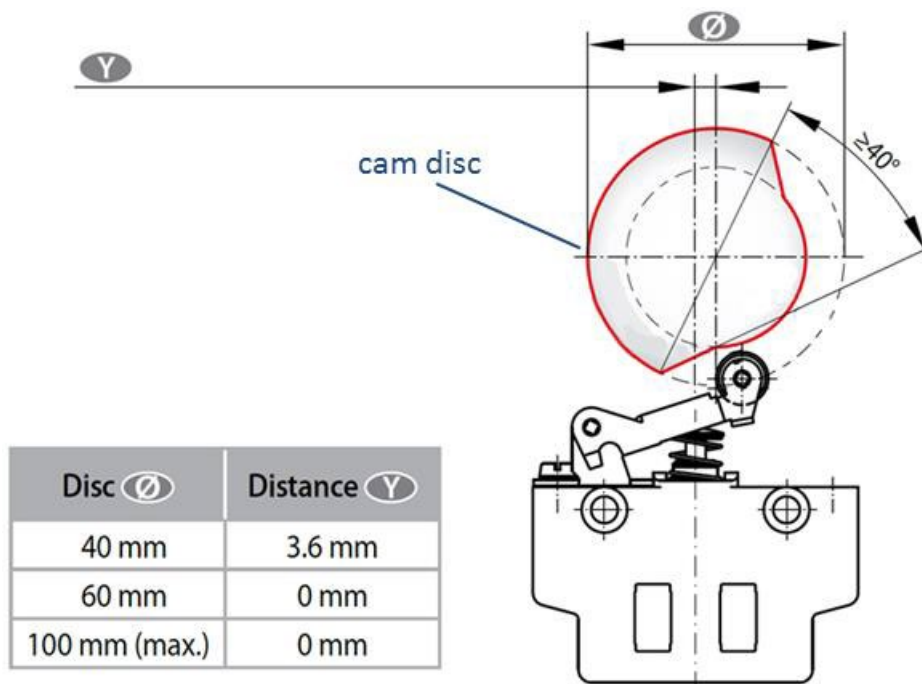

## 7.2 ACTUATION S870

- The flank angle of the linear cam actuator must be  $\geq 40^\circ$ .
- The width of the actuator should exceed the width of the roller.
- The surface of the actuator should be as smooth as possible.

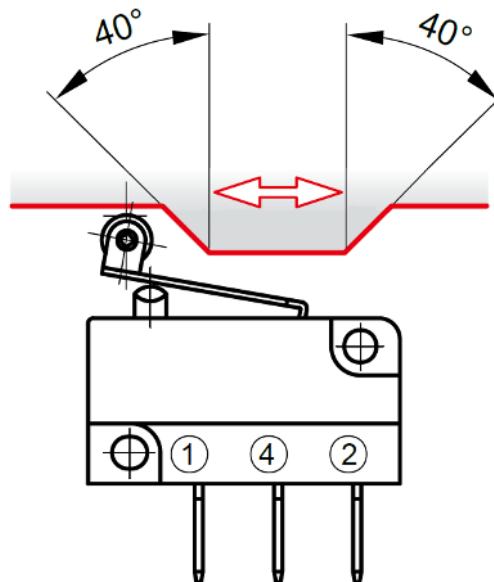

- Disks made from aluminum should not be used.
- The width of the actuator should exceed the width of the roller.
- The surface of the actuator should be as smooth as possible.

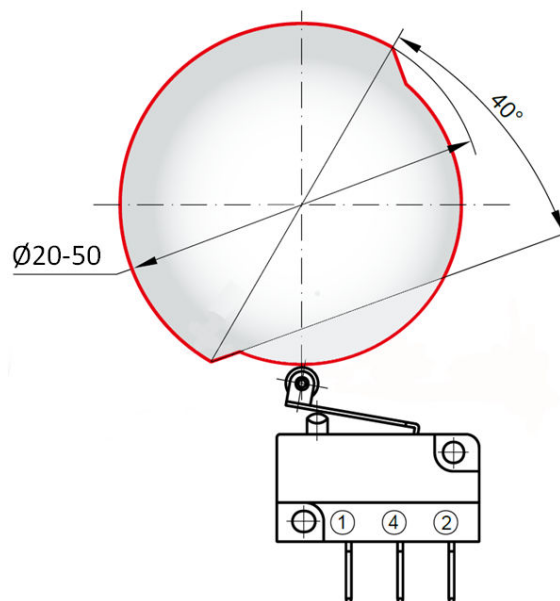

### 7.3 ACTUATION S880

- The flank angle of the linear cam actuator must be  $\geq 50^\circ$ .
- The width of the actuator should exceed the width of the roller.
- The surface of the actuator should be as smooth as possible.

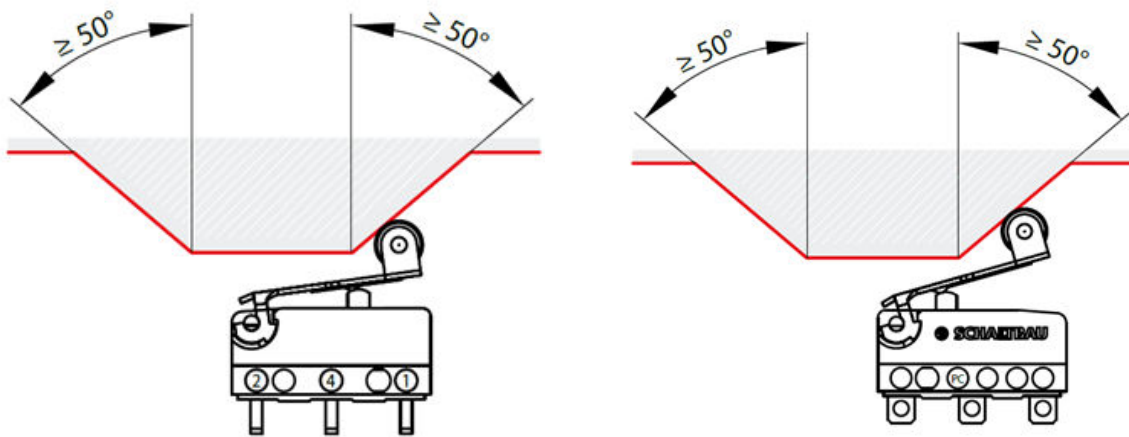

- Disks made from aluminum should not be used.
- The width of the actuator should exceed the width of the roller.
- The surface of the actuator should be as smooth as possible.

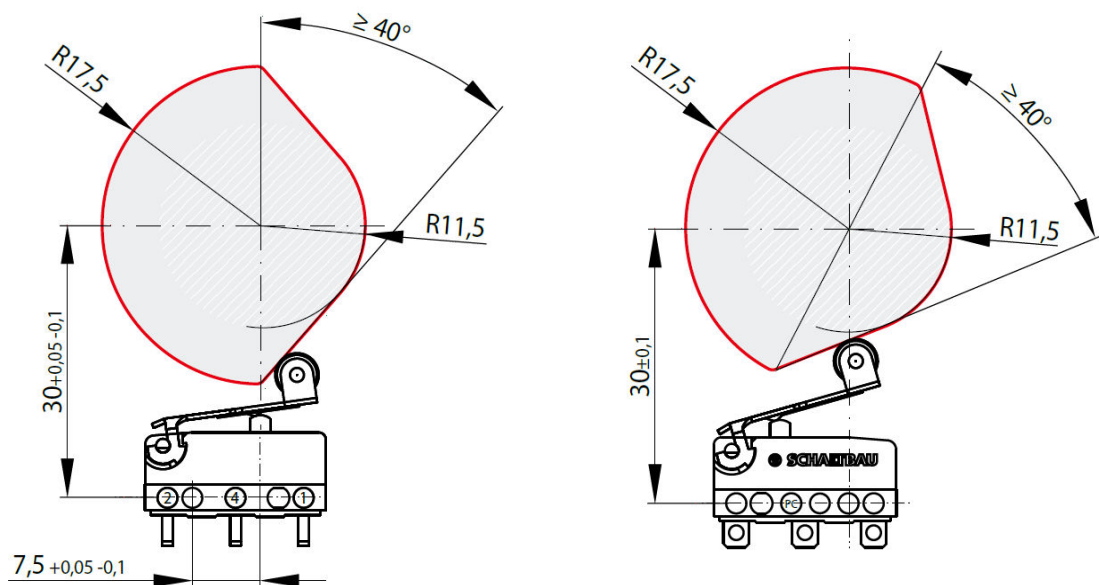

## 8 APPENDIX

### 8.1 SCHALTBAU COLLAR SCREW SHORT VERSION "BS-SK-K":

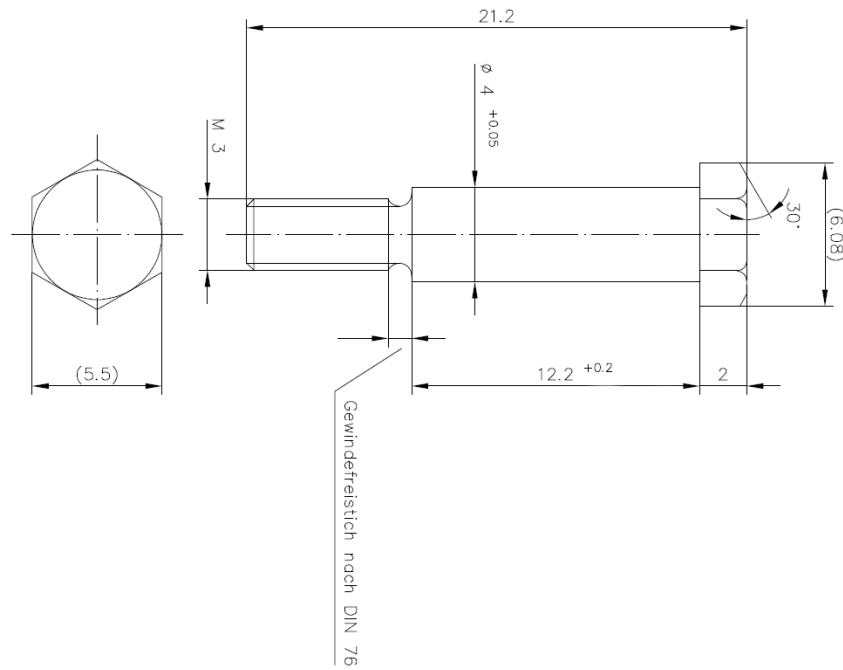

### 8.2 SCHALTBAU COLLAR SCREW LONG VERSION "BS-SK-L":

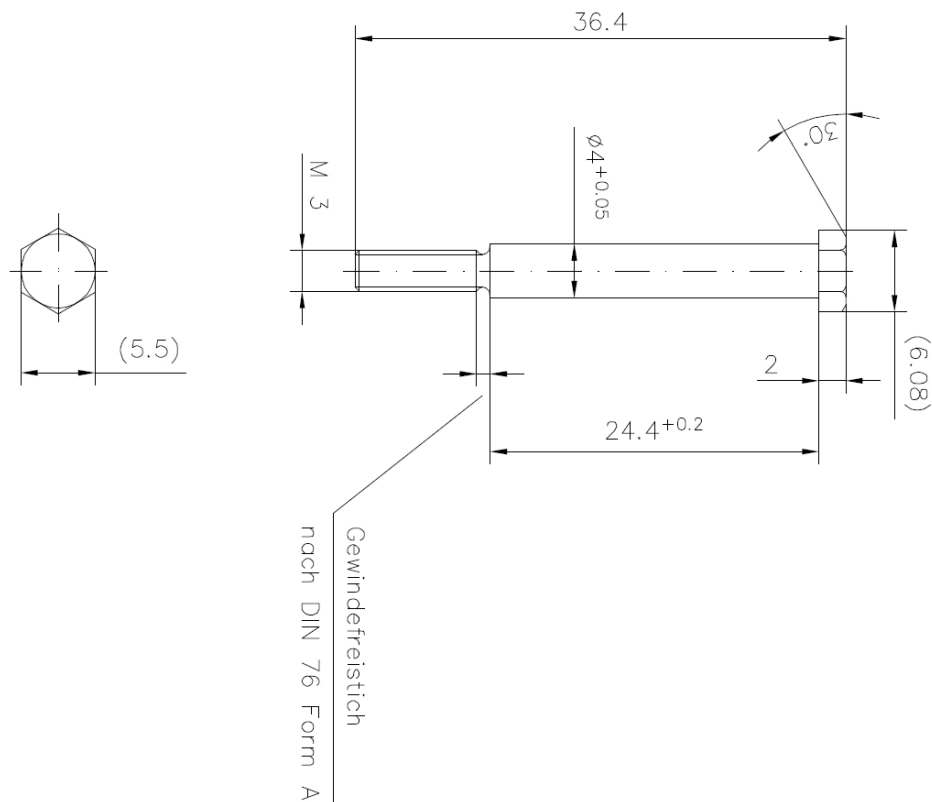

# Schaltbau GmbH

For detailed information on our products and services visit our website – or give us a call!

Schaltbau GmbH  
Hollerithstrasse 5  
81829 Munich  
Germany



Phone +49 89 9 30 05-0  
Fax +49 89 9 30 05-350  
Internet [www.schaltbau.com](http://www.schaltbau.com)  
e-Mail [contact@schaltbau.de](mailto:contact@schaltbau.de)

with compliments:



The production facilities of Schaltbau GmbH have been IRIS certified since 2008.



Certified to DIN EN ISO 14001 since 2002. For the most recent certificate visit our website.



Certified to DIN EN ISO 9001 since 1994. For the most recent certificate visit our website.

## Electrical Components and Systems for Railway Engineering and Industrial Applications

### Connectors

- Connectors manufactured to industry standards
- Connectors to suit the special requirements of communications engineering (MIL connectors)
- Charging connectors for battery-powered machines and systems
- Connectors for railway engineering, including UIC connectors
- Special connectors to suit customer requirements

### Snap-action switches

- Snap-action switches with positive opening operation
- Snap-action switches with self-cleaning contacts
- Snap-action switch made of robust polyetherimide (PEI)
- Snap-action switch with two galvanically isolated contact bridges
- Special switches to suit customer requirements

### Contactors Emergency disconnect switches

- Single and multi-pole DC contactors
- High-voltage AC/DC contactors
- Contactors for battery powered vehicles and power supplies
- Contactors for railway applications
- Terminal bolts and fuse holders
- DC emergency disconnect switches
- Special contactors to suit customer requirements

### Electrics for rolling stock

- Equipment for driver's cab
- Equipment for passenger use
- High-voltage switchgear
- High-voltage heaters
- High-voltage roof equipment
- Equipment for electric brakes
- Design and engineering of train electrics to customer requirements