

3

Contactors

C360K/150/300/500
C360A/150/300/500
C360S/150/300/500

1 pole
AC and bi-directional DC NO contactors
for 150 A, 300 A and 500 A
for railway applications

Installation and
maintenance instructions

Manual C360-M.en

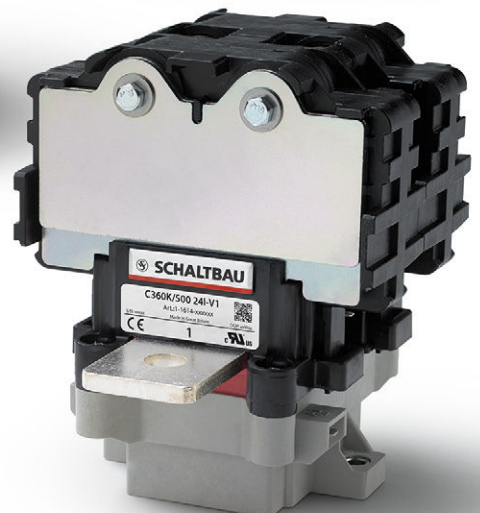

Document Revision History

Date	Rev. version	Description	Pages
2021-11-11	1.0	Initial version	All

Content

1. Important basic information	4
1.1 Legal notes	4
1.2 Conventions for this manual.....	4
2. General and safety information	4
2.1 Observing the manual.....	4
2.2 Duties of the operating company.....	5
2.3 Intended use	5
2.4 Ambient conditions.....	5
3. Hazards and safety precautions.....	6
3.1 Electrical hazards.....	6
3.2 Other hazards	6
3.3 Measures for avoiding damage and malfunctions	7
4. Product information.....	8
4.1 C360 – 1 pole AC and bi-directional DC NO contactors for railway applications	8
4.2 Features	8
4.3 Reliable, robust and economical	8
4.4 Application	8
4.5 Technical information and material properties.....	8
4.6 Overview	9
C360K/150/300/500	9
C360A/150/300/500.....	9
C360S/150/300/500	10
5. Storage.....	11
6. Unpacking.....	11
6.1 Unpacking the device.....	11
6.2 Check parts for transport damage.....	11
7. Installation	12
7.1 Mounting	12
Dimensions/interfaces and further technical specifications.....	12
Preparatory measures.....	12
Mounting holes.....	12
Mounting positions	12
Required minimum clearances	13
Ventilation requirements	15
Safety	15
Tools required.....	15
Installing the contactor.....	15

7.2	Electrical connection	17
	Electrical data and other technical specifications.....	17
	Preparatory measures.....	17
	Safety	18
	Tools required.....	18
	Connecting the S880 auxiliary switch	19
	Creating coil connections	19
	Connecting the main contacts.....	20
7.3	Checks	21
8.	Maintenance	22
8.1	Safety	22
8.2	Preventive maintenance.....	22
	Intervals for regular tests/checks	22
	Regular tests/checks	23
	Removing the arcing chambers.....	25
	Checking the arcing chambers (only with C360K and C360A types)	26
	Checking the main contacts	27
8.3	Corrective maintenance	28
	Replacing the S880 auxiliary switch.....	28
	Replacing the arcing chambers (only with C360A types).....	29
9.	Spare parts	31
10.	Technical data.....	31
11.	Disposal	31

1. Important basic information

1.1 Legal notes

Without prior written consent of SCHALTBAU GmbH, this manual is not allowed to be electronically or mechanically reproduced – as a whole or in parts – be distributed, changed, transmitted, translated into another language or used in any other way.

SCHALTBAU GmbH cannot be held liable for damage caused by non- or only partial observation of the manual.

1.2 Conventions for this manual

This manual describes the installation and maintenance of the contactors.

Cross references are presented in *bold italics*.

To highlight particularly important safety instructions and other information, the following symbols are used in this manual:

DANGER

Indicates a directly threatening dangerous situation. Death or severe injuries will result if it is not prevented.

WARNING

Indicates a possibly dangerous situation. Death or severe injuries may result if it is not prevented.

CAUTION

Indicates a possibly dangerous situation. Medium or minor injuries may result if it is not prevented.

ATTENTION

Indicates a possibly detrimental situation. If it is not prevented, assemblies, the system or property in its surroundings could be damaged.



Indicates technical features and methods to simplify working or indicates information of particular importance.

This manual describes single pole contactors of the following types:

- C360K/150/300/500
- C360A/150/300/500
- C360S/150/300/500

2. General and safety information

The contactors dealt with in this document are intended for use with electrical systems for special applications. They are designed and tested in compliance with generally accepted codes of practice. However, improper use, operation, handling, maintenance of or tampering with electric equipment can cause serious or fatal injury to the user or others, and the appliance or other property can be damaged. Consequently, the operation, maintenance and installation instructions for the contactors must be strictly followed.

If anything is not clear, clarification must be sought with any queries stating the device type and the serial number.

Only authorised and trained personnel are allowed to plan and carry out all mechanical and electrical installations, transport, commissioning, as well as maintenance and repair work.

This applies to the observation of the general installation and safety regulations for electrical systems as well as the proper use of tools approved for this purpose. Electrical equipment requires protection from moisture and dust during installation, operation and storage.

2.1 Observing the manual

- ▶ All personnel must read and understand the instructions in this manual and adhere to them when working with the device.
- ▶ **Always adhere strictly to all safety instructions!**

2.2 Duties of the operating company

- ▶ Observe all applicable national regulations, all safety, accident prevention and environmental protection regulations as well as the recognised technical rules for safe and correct working.
- ▶ Regularly check all fitted protection and safety equipment for correct function.
- ▶ Work on electrical equipment must only be carried out by a qualified electrician or by instructed persons under the supervision and control of a qualified electrician in accordance with electrical regulations.
- ▶ A specialist is someone who, on the basis of their technical training, knowledge and experience as well as knowledge of the relevant regulations, is able to assess the work assigned to them and identify possible dangers.
- ▶ Work on the contactors must only be carried out by personnel who meet the requirements set out in this manual.
- ▶ Personnel must be clearly informed about who is responsible for the maintenance of the contactors.
- ▶ Always perform complete checks after any installation work and/or after any other conversions, alterations or maintenance, in accordance with the following standards:
 - EN/IEC 60077-2
 - EN/IEC 60947-4-1

2.3 Intended use

- ▶ The contactors have been designed and tested according to national and international standards. Due to their unique features they can also be used in a wide range of industrial applications.
- ▶ The contactors must only be used under operating conditions according to the technical specifications and the instructions in this manual.
- ▶ None of the conditions of use, such as voltages, currents or ambient conditions, defined in the corresponding technical data sheets or in our **C360 catalogue** may be overridden. The **C360 catalogue** is available under: https://www.schaltbau.com/media/c360_en.pdf

- ▶ The contactors may only be used when all protective devices are present, have been correctly installed and are fully operational.
- ▶ Contactors may not be used without other safety precautions in potentially explosive atmospheres and/or in aggressive media.
- ▶ Operation without a correctly installed arc chute is not permitted.
- ▶ The device contains unprotected live parts.
- ▶ The prescribed clearances relative to other live parts or earth and other parts must be complied with as well as the safety regulations of the applicable standards.
- ▶ Switching at close to the maximum breaking capacity may require increased minimum clearances! Do not hesitate to ask our advice in respect of any dimensioning.
- ▶ Improper handling of the contactors, e.g. impacts on the floor, may result in breakage, cracks or deformation. Always handle the device with care.
- ▶ Only use the contactors for the specified application and only with original parts. Any other usage of or tampering with the contactors is considered contrary to their intended use. No liability is assumed for damages and accidents caused due to non-compliance with the instructions in this manual or improper use of the contactors.

2.4 Ambient conditions



ATTENTION

The contactors have been design for specific ambient conditions.



- ▶ Only operate the contactors in ambient conditions, such as temperature ranges, degree of soiling, etc., as defined in the corresponding data sheets and in our **catalogue C360**. The **C360 catalogue** is available under: https://www.schaltbau.com/media/c360_en.pdf



3. Hazards and safety precautions



3.1 Electrical hazards

	 DANGER
	<p>The contactors are used for voltage switching. Contact with live electrical parts can result in serious injuries or even death!</p> <p>Live parts are all metal parts belonging directly to one of the circuits or wires connecting to them. All other visible metal parts and wiring may also be live if a fault exists.</p> <p>Before starting any work on the contactors, always comply with the following safety rules:</p> <ul style="list-style-type: none"> ▶ Disconnect on all sides ▶ Secure to prevent switching back on ▶ Clearly identify the working area ▶ Check that a voltage-free state exists ▶ Earth and short circuit; this includes discharging any capacitors in the main circuit ▶ Besides the main power circuits, also disconnect additional and auxiliary circuits ▶ Cover or insulate adjacent live parts ▶ The presence of a voltage-free state can only be clearly identified by a qualified electrician. ▶ When the work has been concluded, follow the procedure in reverse.

3.2 Other hazards

	 WARNING
	<p>Contactors must only be used for the purposes specified in the specifications and data sheets. Incorrect use can cause accidents and severe personal injury.</p> <ul style="list-style-type: none"> ▶ The manufacturer will not be responsible for accidents arising from improper use of the product.

	 CAUTION
	<p>During continuous operation the contactors may become hot. Risk of burns!</p> <ul style="list-style-type: none"> ▶ Before beginning any checks or maintenance on the contactors ensure that the heated components have cooled down.

	 CAUTION
	<p>The contactors contain sharp-edged parts. Risk of injuries!</p> <ul style="list-style-type: none"> ▶ Use appropriate tools for installation and maintenance work on the contactors. ▶ Wear safety gloves when handling sharp-edged components.

3.3 Measures for avoiding damage and malfunctions

ATTENTION

Aggressive liquids may damage the contactors.

- ▶ Ensure the contactors do not come into contact with corrosive liquids.

ATTENTION

Improper handling of the contactors, e.g. dropping on the floor, can result in breaks, cracks and deformation.

- ▶ Ensure the contactors are always handled correctly.
- ▶ Do not throw the contactors on the floor.
- ▶ At regular intervals perform a visual check of the contactors for possible damage.
- ▶ Immediately replace any damaged parts.

ATTENTION

Depending on the product type, contactors can contain permanent magnets. Such magnets can attract ferromagnetic parts resulting in damage to the contactors.

- ▶ Ensure that the contactors are installed in a location where it is not possible for them to attract any ferromagnetic parts.

ATTENTION

Depending on the product type, contactors can contain permanent magnets. These permanent magnets can destroy the data on the magnetic strips of credit or similar cards.

- ▶ Keep credit or similar cards away from the contactors.

ATTENTION

During switching off, strong electromagnetic fields are generated in the vicinity of the contactors. These may influence other components close to the contactors.

- ▶ Make sure that the contactors are installed in a location where no other components are affected.

ATTENTION

In the case of damage, wear and/or soiling of the contactors - in the form of a partial break, sharp edges and discoloured surfaces - the functional reliability of the contactors is no longer ensured.

- ▶ Visually inspect the contactors regularly to detect wear and soiling.
- ▶ Replace damaged parts immediately.
- ▶ Immediately remove any soiling without leaving any residues.
- ▶ Immediately replace any parts with persistent soiling.

ATTENTION

Detent-edged rings and detent-edged washers have a limited life time. After screws secured with detent-edged rings or detent-edged washers have been undone three times, the rings or washers must be replaced by new ones.

- ▶ Record the frequency of undoing of the screws in the work log.
- ▶ Replace detent-edged rings or detent-edged washers with new ones after the screws have been undone three times.

4. Product information

4.1 C360 – 1 pole AC and bi-directional DC NO contactors for railway applications

Compact single-pole NO contactors for AC and DC up to 1,500 volt rated insulation voltage. Making current up to 2,500 amps; conventional thermal current up to 500 amps; short-time current up to 3,000 amps.

The bi-directional DC contactors switch high powers in a small space. With a making capacity of up to 2,500 amps, the compact switchgear is suitable for applications with high inrush current or high capacities.

All versions can continuously conduct up to 500 amps. In the event of a short circuit, 3,000 amps, can even flow for one second without the contacts welding. The full bidirectionality is important for many applications in railway vehicles. Many design variants are also available, matched to a wide range of applications, e.g. as the main contactor in traction and auxiliary converters of battery and hybrid vehicles or as a disconnecter in battery circuits with high currents.

4.2 Features

- ▶ Compact dimensions – high rated insulation voltage U_i up to 1,500 volts
- ▶ High making capacity I_{cm} of up to 2,500 amps
- ▶ High thermal continuous current I_{th} of up to 500 amps
- ▶ High short-time withstand current rating I_{cw} of up to 3,000 amps
- ▶ Full bidirectionality – reliable disconnection of high powers
- ▶ Auxiliary switch with mirror contact function

4.3 Reliable, robust and economical

Contactors of the C360 series are designed for continuous currents of 150 amps, 300 amps and 500 amps. The switchgear has both high making and breaking capacities, and a high short-time withstand current. This ensures high operational safety.

An integrated electronic coil control ensures a constant and reliable switching behaviour independent of the ambient temperature. In addition, the energy consumption and associated heat development of the monostable design is noticeably reduced when switched on.

Inherent to its design, the bistable version consumes no power in either end positions.

Dependent on the application, high requirements can be placed on electromechanical components. The new DC contactors are highly resistant to shock and vibration loads and meet the high requirements of ISO 16750.

4.4 Application

Thanks to many years of experience and competence developing electromechanical switchgear and the mastering DC arcs, Schaltbau has developed an innovative solution with new DC contactors that significantly simplifies applications with DC switching technology. The C360 series is therefore suitable for universal use in railway networks as a DC contactor for traction and auxiliary converters. As the switchgear also reliably masters switching in both current directions, it is ideally suited for applications with energy recovery. Typical examples are traction batteries that are charged and discharged during operation.

- ▶ **Traction contactor for battery or hybrid vehicles**
 - Main contactor in combination with a precharging contactor in traction converter of locomotives, railcars and trams
- ▶ **Contactor for auxiliary converter**
 - Main contactor in combination with a precharging contactor in auxiliary converter of locomotives, railcars and trams
- ▶ **Disconnecting contactor in battery circuits**
 - Disconnecting contactor for battery-powered functions in locomotives and multiple units
 - Contactor for battery-powered functions in passenger coaches
 - Deep discharge protection for batteries in emergency power supplies

4.5 Technical information and material properties

For technical information and material properties, refer to the corresponding data sheets and to our **C360 catalogue**. The **C360 catalogue** is available under:

https://www.schaltbau.com/media/c360_en.pdf

4.6 Overview

C360K/150/300/500

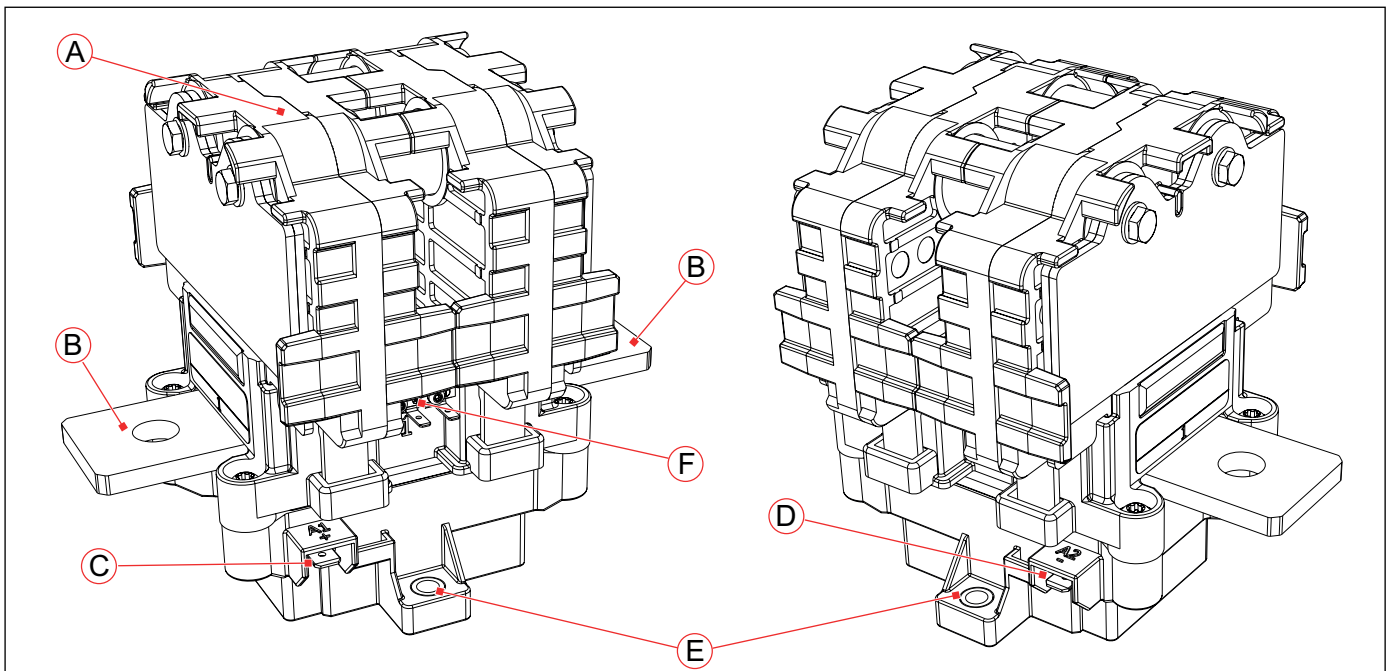

A Arcing chamber unit (removable)

B Main contacts, connection:

- M8 (4.8 ... 6 Nm) for C360K/150

- M10 (8 ... 10 Nm) for C360K/300/500

C Coil terminal A1 (+), flat plug 6.3 x 0.8 mm

D Coil terminal A2 (-), flat plug 6.3 x 0.8 mm

E Fastening holes, for M5 screws

F Auxiliary switch S880 W1R6 k, flat plug connections 2.8 x 0.5 mm (dependent on the design, up to 2 auxiliary switches per contactor are possible)

C360A/150/300/500

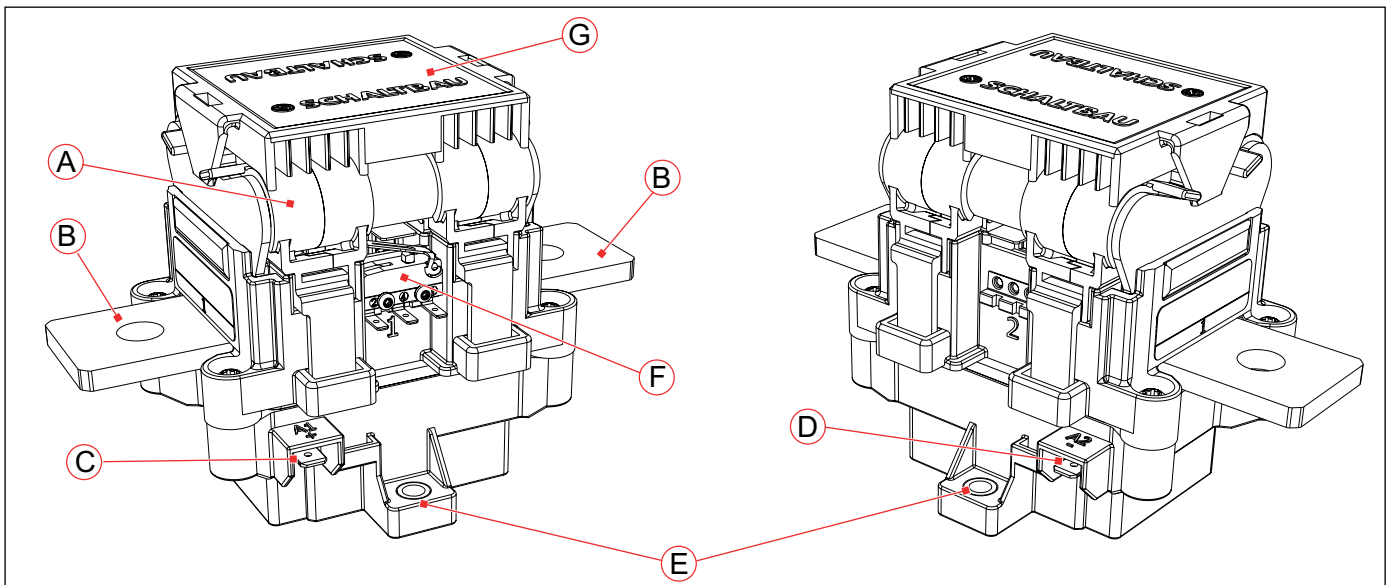

A Arcing chamber unit (removable)

B Main contacts, connection:

- M8 (4.8 ... 6 Nm) for C360A/150

- M10 (8 ... 10 Nm) for C360A/300/500

C Coil terminal A1 (+), flat plug 6.3 x 0.8 mm

D Coil terminal A2 (-), flat plug 6.3 x 0.8 mm

E Fastening holes, for M5 screws

F Auxiliary switch S880 W1R6 k, flat plug connections 2.8 x 0.5 mm (dependent on the design, up to 2 auxiliary switches per contactor are possible)

G Cover cap for arcing chambers (removable)

C360S/150/300/500

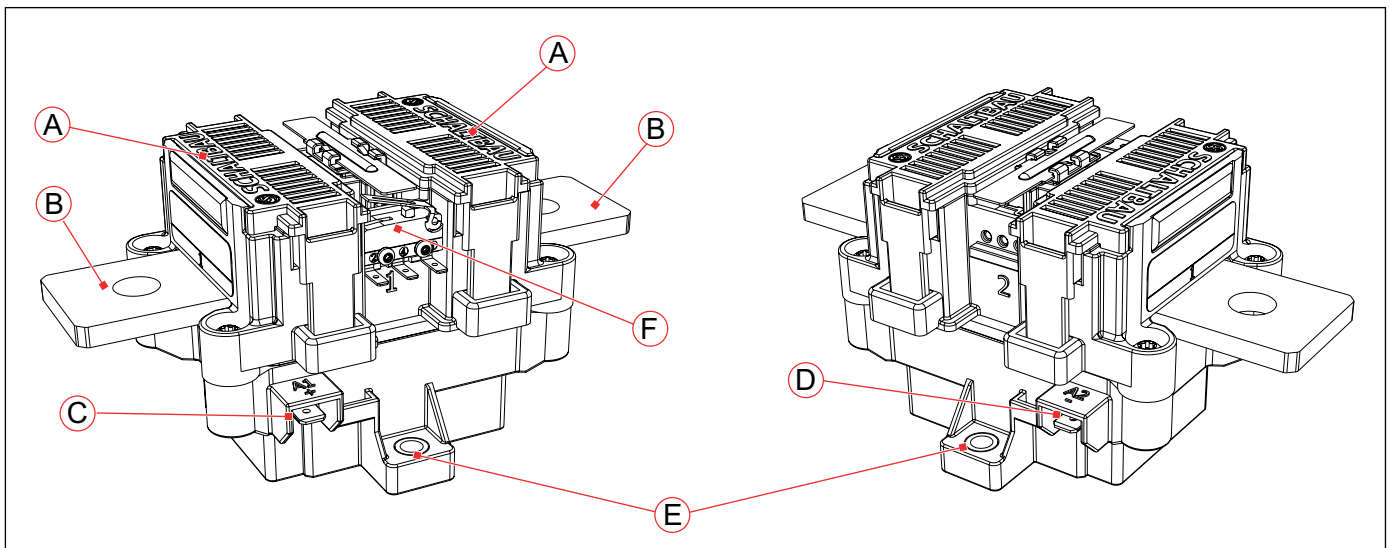

- | | |
|--|--|
| <p>A Arcing chambers (removable)</p> <p>B Main contacts, connection:
- M8 (4.8 ... 6 Nm) for C360S/150
- M10 (8 ... 10 Nm) for C360S/300/500</p> <p>C Coil terminal A1 (+), flat plug 6.3 x 0.8 mm</p> <p>D Coil terminal A2 (-), flat plug 6.3 x 0.8 mm</p> | <p>E Fastening holes, for M5 screws</p> <p>F Auxiliary switch S880 W1R6 k, flat plug connections
2.8 x 0.5 mm (dependent on the design, up to 2 auxiliary switches per contactor are possible)</p> |
|--|--|

5. Storage

ATTENTION

Moisture and dust can damage the contactors. If the device is to be stored for a prolonged period of time:

- ▶ Store the device in its original packaging,
- ▶ Store the device in a dry and dust-free location.

Return shipments

Schaltbau recommends retaining the original packaging for any return shipments.

If the original packaging is not available, care must be taken to pack the contactor in a way that prevents damage during shipment.

6. Unpacking

6.1 Unpacking the device

- ▶ Before opening the packaging, perform a visual inspection for any signs that could indicate damage having occurred during transport (impacts, bumps, dropping, etc.).
- ▶ If any signs indicate that the contactor has been subject to excessive impacts do not install it.

6.2 Check parts for transport damage

ATTENTION

If parts are damaged, functional reliability of the contactor has been lost.

- ▶ Before installing, check all parts for possible transport damage.
- ▶ Do not install damaged parts.

7. Installation

7.1 Mounting

Dimensions/interfaces and further technical specifications

The dimensions and other technical specifications are given in the respective data sheets or can be found in our *C360 catalogue*. The *C360 catalogue* is available under: https://www.schaltbau.com/media/c360_en.pdf

Preparatory measures

- ▶ A suitable mounting plate with 2 mounting holes in accordance with the following dimensional drawing (*Fig. 1*) must be provided for fastening of the contactors.
- ▶ The mounting holes can be either:
 - threaded holes (for threaded screws)
 - or through holes (for threaded screws and nuts)
- ▶ Fastening of the contactors on the mounting plate is performed using two M5 mounting screws.
 - The length of the mounting screws must be determined dependent on the structural circumstances.
 - To secure the mounting screws so that they do not come loose, appropriate screw locking elements must be provided. Schaltbau recommends using Schnorr washers (or similar).
 - The mounting screws must be equipped with washers (resting on the device). Installation without washers is not permitted!
 - The mounting screws must be tightened to a torque of 2.3 Nm (screws of strength class 4.6)

Mounting holes

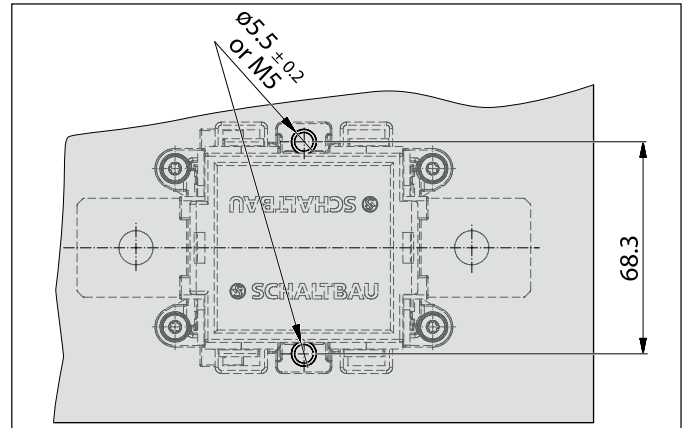

Fig. 1: Dimensions and layout of mounting holes

Mounting positions

The contactors are designed for horizontal or vertical mounting. Examples of correct installation positions are presented in *Fig. 2* to *Fig. 4* (*under A and B*). Incorrect mounting positions, suspended over head as shown in *Fig. 2* to *Fig. 4* (*under C*).

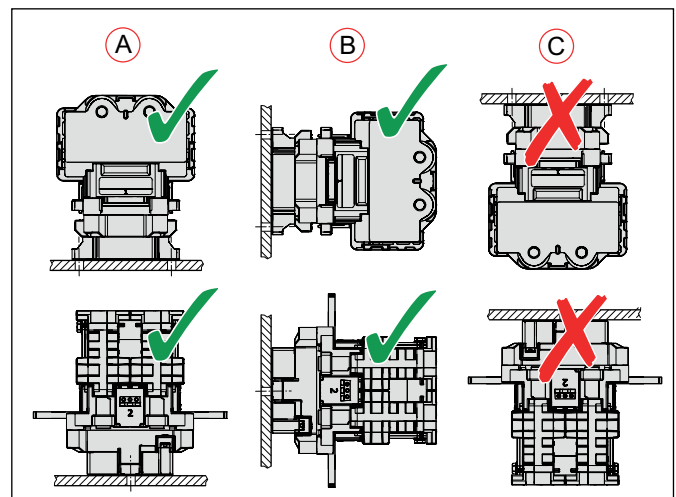

Fig. 2: C360K: Examples of correct installation positions (A and B) and incorrect installation position (C).

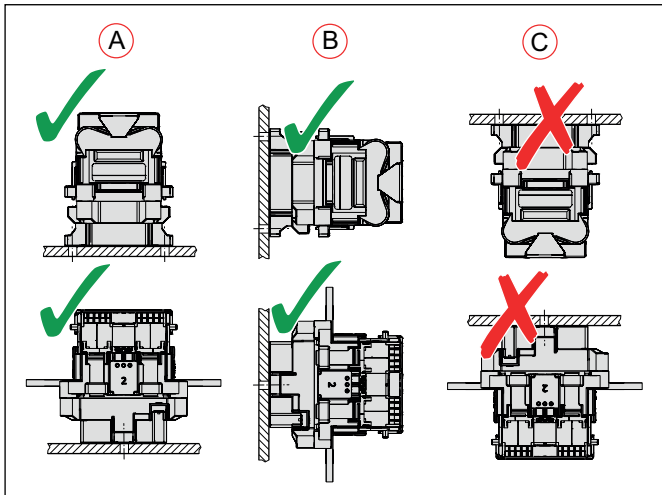

Fig. 3: C360A: Examples of correct installation positions (A and B) and incorrect installation position (C).

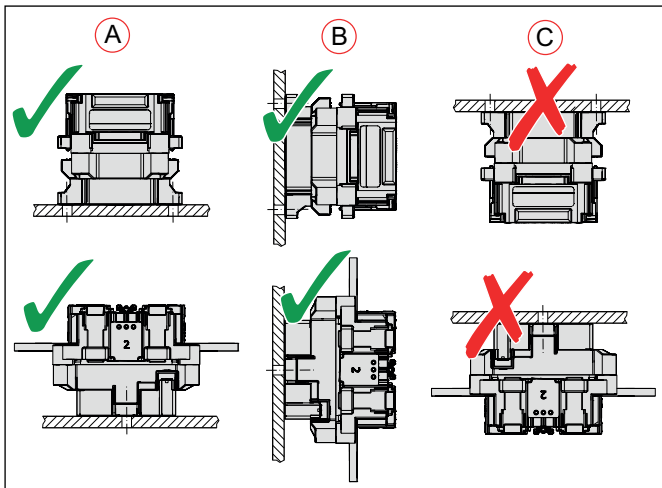

Fig. 4: C360S: Examples of correct installation positions (A and B) and incorrect installation position (C).

Required minimum clearances

▶ Switching of high voltage currents produces electric arcs and it is possible that plasma will escape from the openings of the arcing chambers. Therefore, it is extremely important to maintain the minimum clearances to ground/earth and the connecting bars to avoid flashovers.

Minimum clearances for type C360K contactors

A minimum clearance from magnetic or magnetised parts is required on all sides and above for type C360K contactors. See *C360 catalogue*.

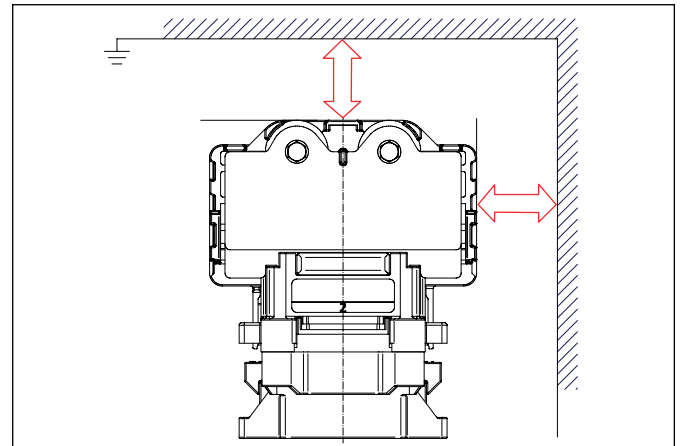

Fig. 5: C360K: Minimum clearance required from magnetic and earthed component. Clearances see *C360 catalogue*.

Minimum clearances for type C360A contactors

Operation with and without a cover cap (1) is possible for type C360A contactors.

- ▶ Operation with a cover cap (1):
 - Minimum clearance on all sides: see *C360 catalogue*.
 - When operating with a cover cap (1), a minimum upward clearance is not necessary

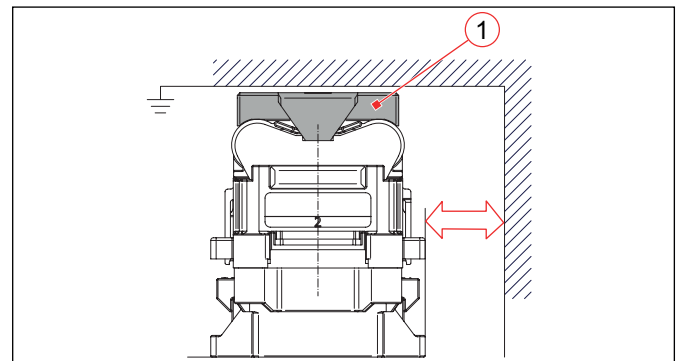

Fig. 6: C360A: See the *C360 catalogue* for the required minimum clearances for operation with a cover cap (1)

- ▶ For operation without a cover cap:
 - Minimum clearance on all side and above: see *C360 catalogue*

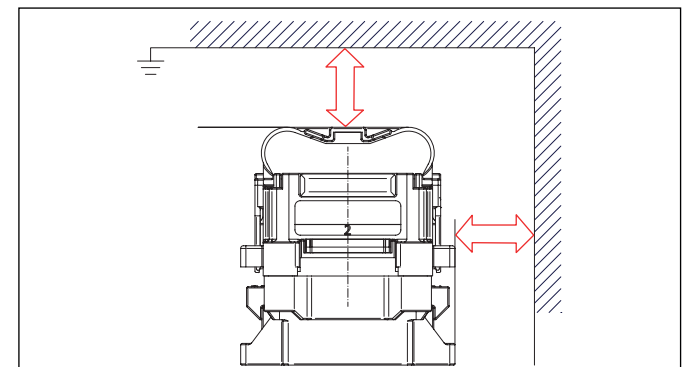

Fig. 7: C360A: See the *C360 catalogue* for the required minimum clearances for operation without a cover cap

- ▶ Operation with a cover cap (1) and additional side isolating plates (2):
 - The isolating plates (2) are inserted in the side lugs (3) on the contactor housing.

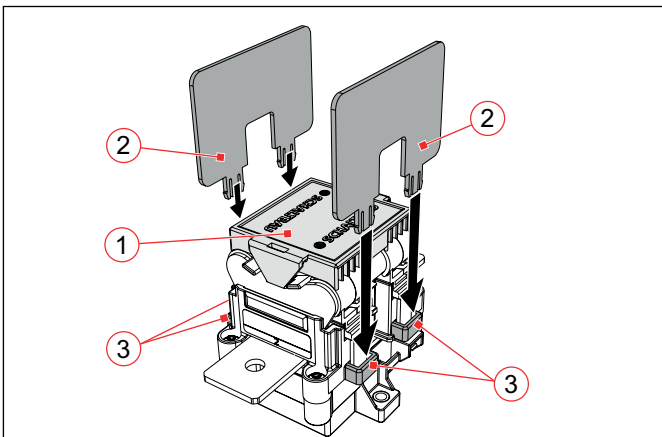

Fig. 8: C360A: Side isolating plates (2) for insertion in the lugs (3) on the housing reduce the required minimum clearance on the sides

- When operating with additional side isolating plates (2), a minimum clearance on the sides is fundamentally not necessary, see Fig. 9.
- With additional side isolating plates (2), two symmetrically inverted contactors can be installed next to each other without an intermediate space, see Fig. 10.

ATTENTION

When using side isolating plates (2), it is fundamentally possible to fit the contactors connected directly to earth.

However, you must ensure that there is sufficient space for routing the wires for auxiliary switches and coil terminals (Fig. 9/4) and Fig. 10/4).

Otherwise, if the wires are routed too tightly, the auxiliary switch connections and/or coil terminals can break off or bend.

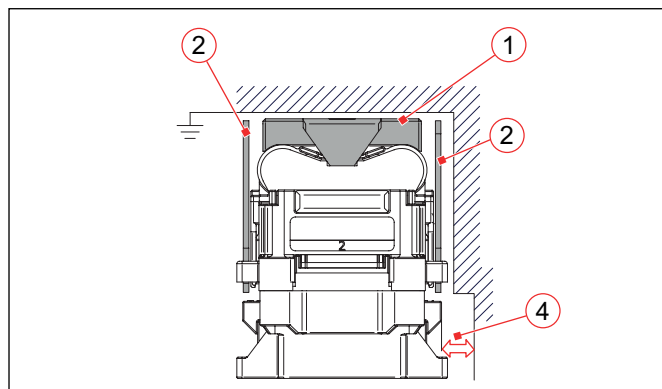

Fig. 9: C360A: When operating with a cover cap (1) and additional side isolating plates (2), no minimum clearances are necessary. However, there must be sufficient space for routing the wires for auxiliary switches and coil terminals (4).

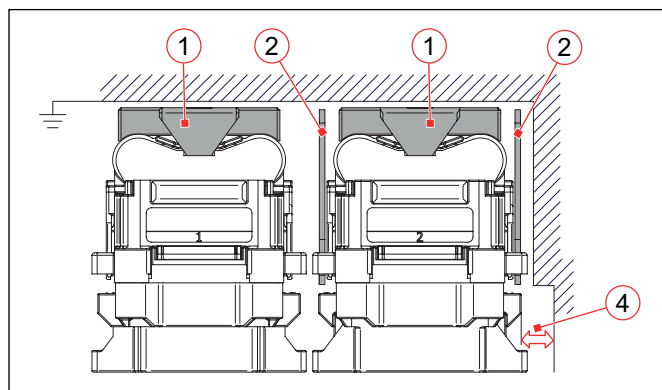

Fig. 10: C360A: When operating with additional side isolating plates (2), two symmetrically inverted contactors can be installed next to each other without an intermediate space. However, there must be sufficient space for routing the wires for auxiliary switches and coil terminals (4).

Minimum clearances for type C360S contactors

Type C360S contactors are operated as standard without cover caps.

- ▶ A minimum side clearance is not required
- ▶ Minimum upward clearance: see C360 catalogue

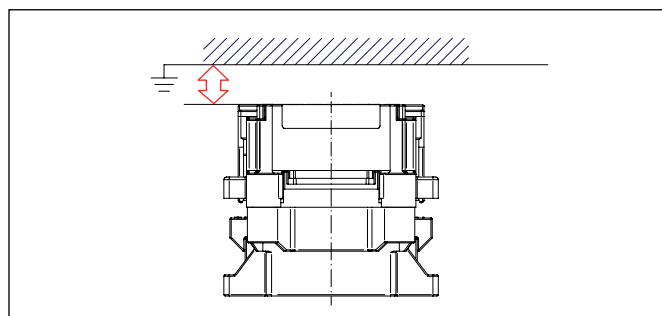

Fig. 11: C360S: Required minimum clearance, see C360 catalogue

Ventilation requirements

- ▶ Ensure sufficient ventilation in the installation area, especially when disconnecting heavy loads. This allows the plasma to be dissipated more quickly to reduce the risk of flash-overs and corrosion.

Safety

- ▶ Installation must be performed by qualified trained personnel.

ATTENTION

When installing, ensure that no dirt can get into the contactor as a result of surrounding building activities.

ATTENTION

Detent-edged rings and detent-edged washers have a limited life time. After screws secured with detent-edged rings or detent-edged washers have been undone three times, the rings or washers must be replaced by new ones.

- ▶ Record the frequency of undoing of the screws in the work log.
- ▶ Replace detent-edged rings or detent-edged washers with new ones after the screws have been undone three times.

Tools required

- ▶ Socket spanner set, hexagon nuts
- ▶ Open-ended spanner set
- ▶ Torque wrench
- ▶ Hex key set with ball end or angled hex keys

Installing the contactor

ATTENTION

- ▶ When screwing in and tightening the mounting screws, ensure that the tool does not collide with the contacts (1) of the auxiliary switch resulting in bending of the contacts.
- ▶ Use for example a hexagon socket screw (4) with washer and suitable screw locking elements and a hex key with ball head (2) or an angled hex key.

In this way, you can position the tool (2) at an inclination angle with sufficient clearance to the contacts (1), thus preventing any contact damage.

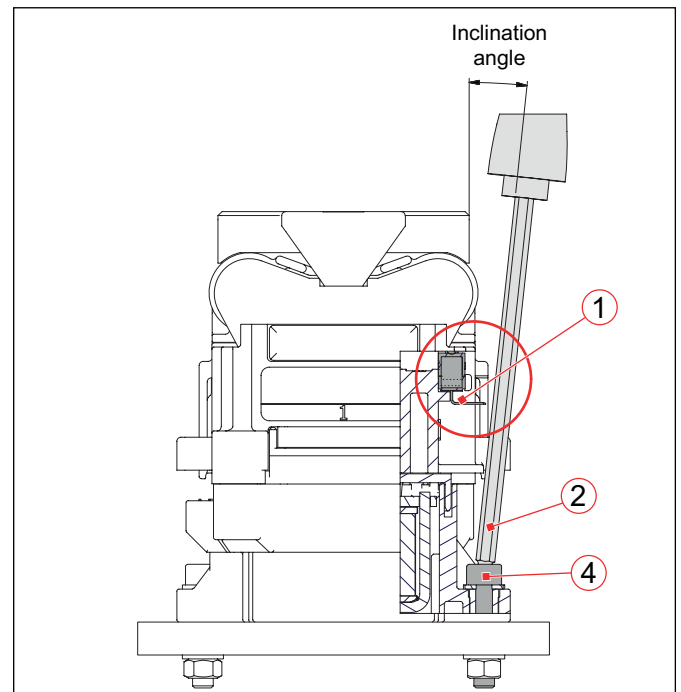

Fig. 12: When screwing in and tightening the mounting screws, position the tool at an angle to prevent bending of the auxiliary switch contacts.

- ▶ Ensure that the contact surfaces on the mounting plate (5) are free from dirt and other contamination (e.g. metal chips).
- ▶ Position the contactor (3) on the mounting plate (5) which is provided with mounting holes.

ATTENTION

- ▶ The mounting screws M5 (4) must be equipped with washers (resting on the device). Installation without washers is not permitted!
- ▶ Secure the contactor to the mounting flange with 2 mounting screws M5 (4) on the mounting plate (5).
 - In designs with the mounting holes implemented as threaded holes, screw the mounting screws into the holes directly, not forgetting the washers.
 - In designs with through holes, fit the mounting screws and washers and tighten the screws using suitable screw locking elements and nuts.
- ▶ The mounting screws (4) must be tightened to a torque of 2.3 Nm (screws of strength class 4.6)

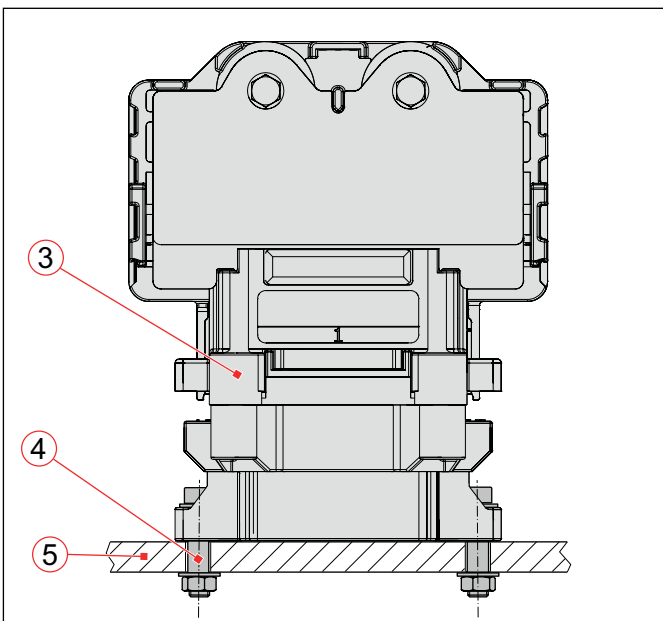

Fig. 13: C360K/150/300/500: Installing the contactor on the mounting plate

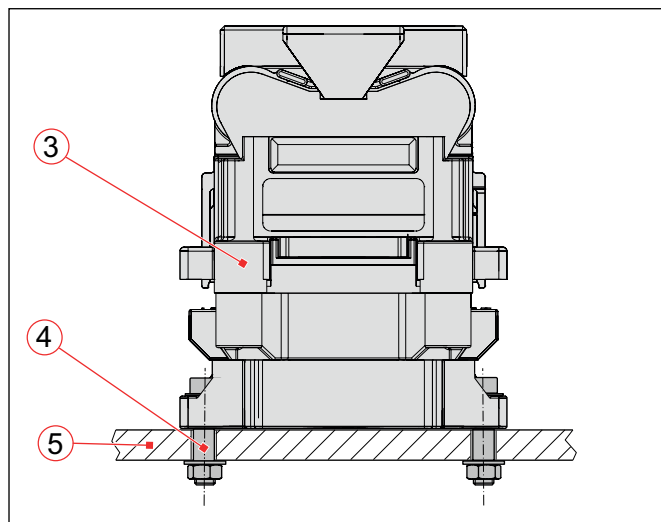

Fig. 14: C360A/150/300/500: Installing the contactor on the mounting plate

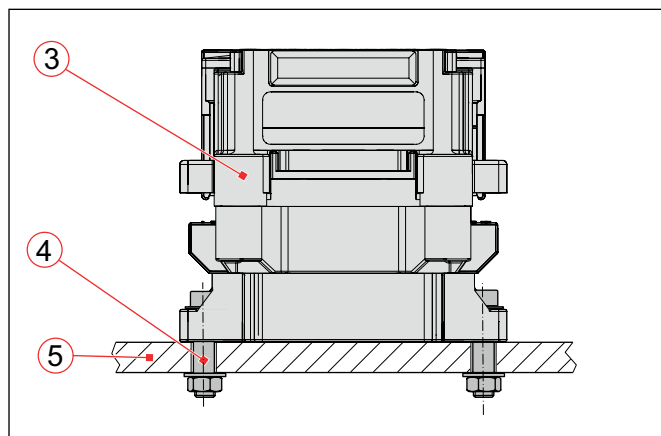

Fig. 15: C360S/150/300/500: Installing the contactor on the mounting plate

7.2 Electrical connection

Electrical data and other technical specifications

For the power consumption of the magnetic drive system and electrical data of the auxiliary switches as well as other technical specifications, refer to the respective data sheets and to our *C360 catalogue*. The *C360 catalogue* is available under:

https://www.schaltbau.com/media/c360_en.pdf

Preparatory measures

- ▶ Connection of the main power circuit can be implemented with wires or busbars.
- ▶ If connecting wires are used, they must be selected taking into consideration the insulation class and the ambient conditions.
- ▶ The minimum conductor cross-sections for the connecting wires are given in our *C360 catalogue* and must be adhered to.
The *C360 catalogue* is available under:
https://www.schaltbau.com/media/c360_en.pdf
- ▶ The connecting wires of the main power circuit must be fitted with appropriate ring terminals (for M8 or M10 terminal screws).
- ▶ The terminal screws for the main contacts and the maximum permissible torque are specified for the various contactors as follows:

Type	Terminal screws	Torque
C360K/150 C360A/150 C360S/150	M8	4.8 ... 6 Nm
C360K/300 C360A/300 C360S/300	M10	8 ... 10 Nm
C360K/500 C360A/500 C360S/500	M10	8 ... 10 Nm

- ▶ Schaltbau recommends Schnorr washers (or similar) to prevent the terminal screws from coming loose. The terminal screws must be tightened with the specified torque (see table).
- ▶ The connections for coils and auxiliary switches are made with flat plugs. Consequently, the control wires must be equipped with receptacles:
 - Coil terminal: Flat plug 6.3 x 0.8 mm
 - Auxiliary switch connection: Flat plug 2.8 x 0.5 mm
- ▶ The maximum permissible conductor cross-section of the auxiliary contact control wires is 1 mm²/AWG 18 stranded wire.

Safety

DANGER



The contactors are used for voltage switching. Contact with live electrical parts can result in serious injuries or even death!

Live parts are all metal parts belonging directly to one of the circuits or wires connecting to them. All other visible metal parts and wiring may also be live if a fault exists.

Before starting any work on the contactors, always comply with the following safety rules:

- ▶ Disconnect on all sides
- ▶ Secure to prevent switching back on
- ▶ Clearly identify the working area
- ▶ Check that a voltage-free state exists
- ▶ Earth and short circuit; this includes discharging any capacitors in the main circuit
- ▶ Besides the main power circuits, also disconnect additional and auxiliary circuits
- ▶ Cover or insulate adjacent live parts
- ▶ The presence of a voltage-free state can only be clearly identified by a qualified electrician.
- ▶ When the work has been concluded, follow the procedure in reverse.

ATTENTION

Detent-edged rings and detent-edged washers have a limited life time. After screws secured with detent-edged rings or detent-edged washers have been undone three times, the rings or washers must be replaced by new ones.

- ▶ Record the frequency of undoing of the screws in the work log.
- ▶ Replace detent-edged rings or detent-edged washers with new ones after the screws have been undone three times.

Tools required

- ▶ Socket spanner set, hexagon nuts
- ▶ Open-ended spanner set
- ▶ Torque wrench
- ▶ Continuity tester
- ▶ Cable ties

Connecting the S880 auxiliary switch

The control wires for the auxiliary contact must be fitted with receptacles (2.8 x 0.5 mm).

- ATTENTION**
- ▶ The maximum permissible conductor cross-section of the auxiliary contact control wires is 1 mm² / AWG 18 stranded wire.
 - ▶ Bending of the connection angles on the auxiliary switch is not permitted!
 - ▶ Move and route the control wires and receptacles only in the direction of plugging, see **Fig. 16**.
 - ▶ Mechanically secure the control wires to minimise feedback effects of forces caused by the wires (e. g. shock, vibrations) acting on the terminals.

▶ Plug the pre-assembled control wires with the receptacles (1) to the connections (2) of the auxiliary switch.

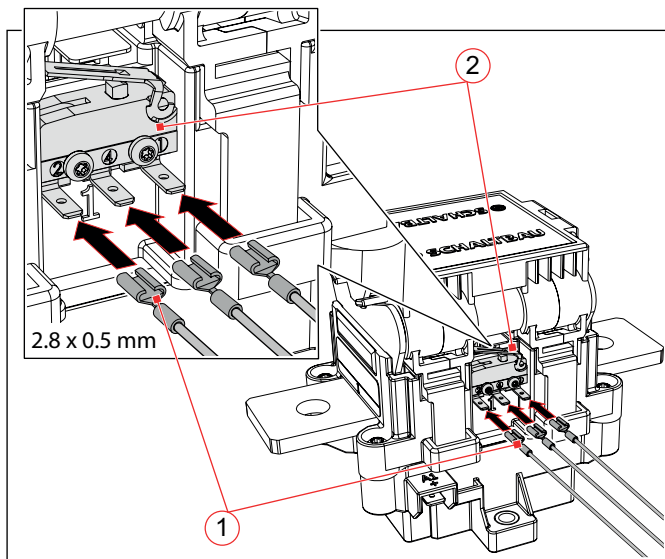

Fig. 16: Connecting the S880 auxiliary switch (the figure shows C360A, the procedure is identical for C360K and C360S)

Creating coil connections

The control wires for the coil terminal must be fitted with receptacles (6.3 x 0.8 mm).

- ATTENTION**
- ▶ Bending of the coil terminals is not permissible!
 - ▶ Move and route the control wires and receptacles only in the direction of plugging, see **Fig. 17**.
 - ▶ Mechanically secure the control wires to minimise feedback effects of forces caused by the wires (e. g. shock, vibrations) acting on the terminals.

▶ Plug the prepared control wires with the receptacles (1/3) to both coil terminals A1+ (2) and A2- (4).

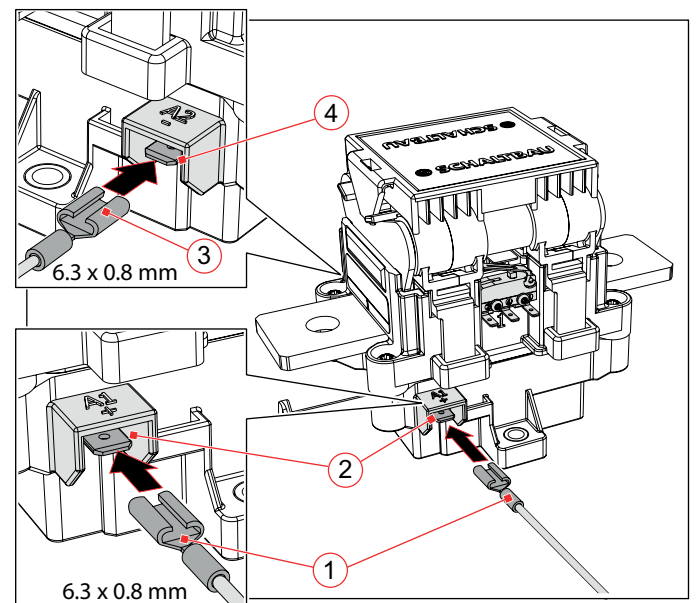

Fig. 17: Creating coil connections (the figure shows C360A, the procedure is identical for C360K and C360S)

Connecting the main contacts

ATTENTION

Ensure that the connection points for the main contacts are free from corrosion.

Connection example using wires

The connecting wires of the main power circuit must be fitted with appropriate ring terminals (for M8 or M10 terminal screws).

- ▶ Route the pre-assembled connecting wires to both main contacts (4).
- ▶ Screw the ring terminals (3) in place from above using the terminal screws (1), nuts (5) and suitable screw locking elements (2) to the main contact (4).
 - Schaltbau recommends using Schnorr washers (or similar).
- ▶ Tighten the screws (1) to the prescribed torque:
 - With M8 terminal screws: 4.8 ... 6 Nm
 - With M10 terminal screws: 8 ... 10 Nm

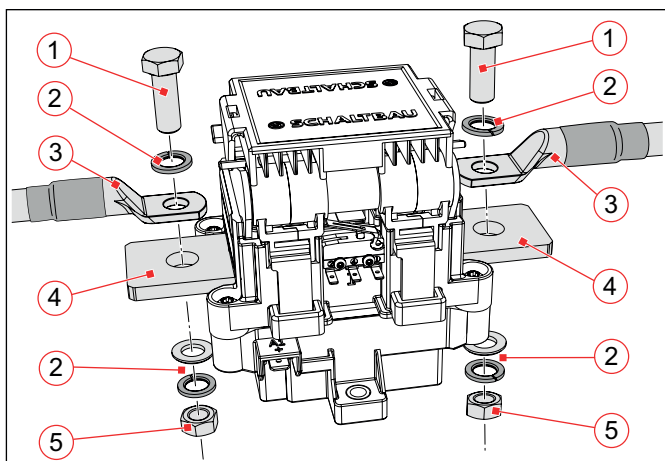

Fig. 18: Connecting the main contacts: Example of connection using cables (the figure shows C360A, the procedure is identical for C360K and C360S)

Connection example using busbars

As an alternative to connection using wires, the main power circuit can also be connected with busbars. Examples for the connection with busbars are shown in Fig. 19 and Fig. 20.

- ▶ Route the busbars (6) to both main contacts (4).
- ▶ Screw the busbars (6) to the main contacts (4) using the terminal screws (1), nuts (5) and suitable screw locking elements.
 - Schaltbau recommends using Schnorr washers (or similar).
- ▶ Tighten the terminal screws (1) to the prescribed torque:
 - With M8 terminal screws: 4.8 ... 6 Nm
 - With M10 terminal screws: 8 ... 10 Nm

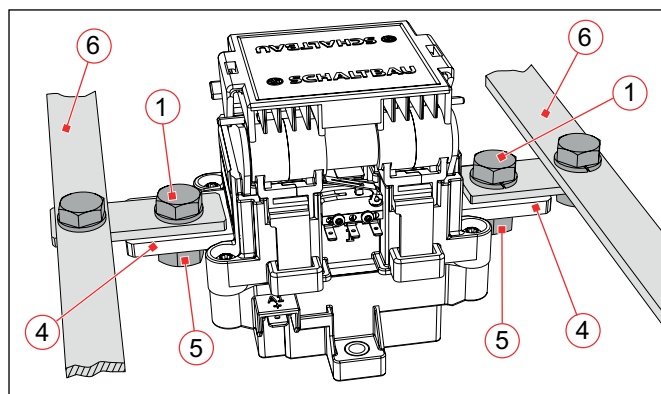

Fig. 19: Connecting the main contacts: Example of connection using busbars (6) (the figure shows C360A, the procedure is identical for C360K and C360S)

If the busbars are very stiff, the use of compensating angles (7) is recommended. In this way tolerances can be allowed for in all three planes.

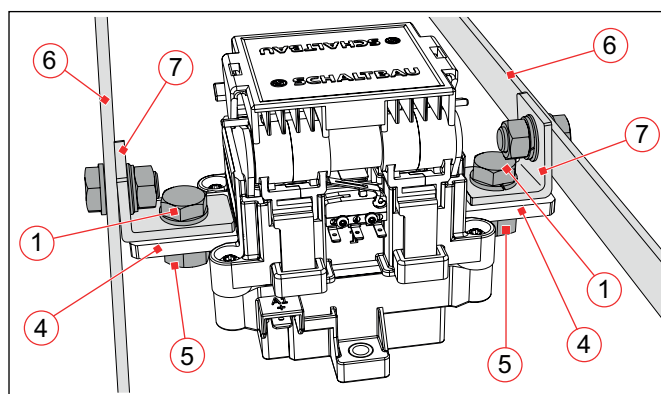

Fig. 20: Connecting the main contacts: Example of connection using busbars (6) and compensating angles (7) (the figure shows C360A, the procedure is identical for C360K and C360S)

7.3 Checks

After the installation, perform the following checks:

- ▶ Check that the contactors are correctly installed on the mounting plate and tightly screwed in place.
- ▶ Check that the connecting wires or busbars are correctly installed and fit tightly at the main contacts.
- ▶ Check that the control wires of the coil terminals are correctly installed and have the correct polarity.
- ▶ Check that the control wires are correctly connected to the auxiliary switch.
Check the correct assignment and function of the auxiliary switch using a continuity tester.
- ▶ Switch the contactor several times without activating the main power circuit.
- ▶ Check the pull-in and drop-off voltage based on the Schaltbau specifications. See *C360 catalogue*.
- ▶ Check the routing of the wiring. Wires must not be squeezed or bent. If applicable bundle and secure wires using cable ties.
- ▶ After every installation or after maintenance, check the contactor for correct operation in accordance with the following standards:
 - EN/IEC 60077-2
 - EN/IEC 60947-4-1

8. Maintenance

Note the expert knowledge which is essential for carrying out maintenance work, referred to in chapter "2. General and safety information".

8.1 Safety

	⚠ DANGER
	<p>The contactors are used for voltage switching. Contact with live electrical parts can result in serious injuries or even death!</p> <p>Live parts are all metal parts belonging directly to one of the circuits or wires connecting to them. All other visible metal parts and wiring may also be live if a fault exists.</p> <p>Before starting any work on the contactors, always comply with the following safety rules:</p> <ul style="list-style-type: none"> ▶ Disconnect on all sides ▶ Secure to prevent switching back on ▶ Clearly identify the working area ▶ Check that a voltage-free state exists ▶ Earth and short circuit; this includes discharging any capacitors in the main circuit ▶ Besides the main power circuits, also disconnect additional and auxiliary circuits ▶ Cover or insulate adjacent live parts ▶ The presence of a voltage-free state can only be clearly identified by a qualified electrician. ▶ When the work has been concluded, follow the procedure in reverse.

8.2 Preventive maintenance

Contactors of the C360 series are maintenance-free within the rated mechanical life time. The electrical life time depends on the number of switching cycles under heavy load conditions and may vary for different applications. In normal use, this corresponds to a decade-long operating period.

Intervals for regular tests/checks

To ensure the correct function and a prolonged operational life span of the contactors, the following checks and maintenance must be regularly performed.

Test/check	Interval
External visual inspection of the contactor	▶ 1x per year
Check of the main contacts (both, stationary and moving contacts)	▶ 1x to 2x per year
Checking of the auxiliary switch	▶ Every 2 years
Auxiliary switch replacement	▶ After 1 million actuations

If the contactors are operated in a particularly dirty environment, the visual checks should be performed at shorter intervals. Dirt can impair the clearance and creepage distances, which can result in a shorter service life or to a malfunction.

Extraordinary checks need only be carried out if there has been a significant and extraordinarily high recorded number of switching cycles under short-circuit conditions.

	⚠ DANGER
	<p>If damage to the contactor, wires or bus-bars is visible, the safety of the contactor is no longer guaranteed.</p> <ul style="list-style-type: none"> ▶ Immediately submit any damaged contactors or components for maintenance.

ATTENTION

Detent-edged rings and detent-edged washers have a limited life time. After screws secured with detent-edged rings or detent-edged washers have been undone three times, the rings or washers must be replaced by new ones.

- ▶ Record the frequency of undoing of the screws in the work log.
- ▶ Replace detent-edged rings or detent-edged washers with new ones after the screws have been undone three times.

Regular tests/checks

All of the maintenance activities that may be carried out on the contactors by skilled personnel are listed below.

Component	Tests/checks	Measures
Wires/busbars	Check for: <ul style="list-style-type: none"> ▶ damaged wires, cable lugs ▶ damaged insulation ▶ damaged busbars ▶ kinked or crushed wires ▶ loose or missing fastening elements ▶ correct tightening torque of the terminal screws 	In case of faults: <ul style="list-style-type: none"> ▶ immediately replace damaged wires or cable lugs ▶ immediately replace damaged busbars ▶ tighten loose fastening elements immediately replace missing fastening elements ▶ tighten the terminal screws to the rated torque
Contactor housing	Check for: <ul style="list-style-type: none"> ▶ dirt ▶ damage or wear ▶ loose or missing fastening elements 	In case of faults: <ul style="list-style-type: none"> ▶ remove any dirt that may be present ▶ if the contactor housing is damaged or heavily worn replace the entire contactor ▶ tighten loose fastening elements immediately replace missing fastening elements ▶ tighten a loose contactor immediately
Switching chamber	Check for: <ul style="list-style-type: none"> ▶ Dirt (thin soot layer permissible) ▶ Damage or wear of the contact bridge cover 	In case of faults: <ul style="list-style-type: none"> ▶ remove any dirt that may be present ▶ if the web width of the contact bridge cover is less than 5 mm, replace the entire contactor (see <i>"Checking the contact bridge cover for wear", Fig. 27</i>).

Component	Tests/checks	Measures
Arcing chambers	<p>Check for:</p> <ul style="list-style-type: none"> ▶ loose seating of the cover cap ▶ loose parts ▶ damage or wear <p>Arcing chamber wear criterion for C360K and 360A types (not necessary with C360S types): The arcing chamber must be replaced no later than when the width of the web at its thinnest point is worn down to 1 mm residual thickness. (The width of the web has been optimised in respect of the material properties and the wear behaviour under the thermal loading of the electric arc and serves as an indicator for the overall arcing chamber wear). In this respect, see section "8.2 Preventive maintenance" / "Checking the arcing chambers (only with C360K and C360A types)".</p>	<p>In case of faults:</p> <ul style="list-style-type: none"> ▶ position the loose cover cap correctly ▶ Arcing chamber replacement, see section "8.3 Corrective maintenance" / "Replacing the arcing chambers (only with C360A types)"
Main contacts (both stationary contacts and moving contact bridge)	<p>Prior to checking the main contacts, the arcing chamber must first be removed, see section "8.2 Preventive maintenance" / "Removing the arcing chambers". Thereafter, the main contacts are accessible and can be checked with the aid of an inspection mirror for:</p> <ul style="list-style-type: none"> ▶ damage or wear ▶ traces of combustion residue (slight soot deposits permitted) <p>A certain level of experience is required to assess the state of the contacts. Even after a few load switching cycles, to a lay user the contacts appear worn and the surroundings fouled. Replacement of the contactor is only necessary after more than 70% of the contact material is burnt through.</p>	<p>In case of faults:</p> <ul style="list-style-type: none"> ▶ if more than 70% of the contact material is burnt through, replace the contactor
Auxiliary switch S880	<p>Check for:</p> <ul style="list-style-type: none"> ▶ dirt ▶ damage or wear on the housing ▶ signs of short circuits <p>The auxiliary switches can be accessed from the outside for a simple visual inspection. Under normal working condition (there have been no short circuits in the control circuit) the main switch must be replaced after no more than one million actuations in accordance with this manual.</p>	<p>If faults exist or after 1 million actuations:</p> <ul style="list-style-type: none"> ▶ replace the auxiliary switch, see section "8.3 Corrective maintenance" / "Replacing the S880 auxiliary switch"

Removing the arcing chambers

Prior to the following tests/checks, the arcing chambers must be removed from the housing of the contactors.

- Checking the main contacts for wear
- Checking the arcing chamber for wear (only with C360K and C360A types)

Removing the arcing chamber unit (C360K and C360A types)

- ▶ Either manually or using a screwdriver, release the opposing snap-fit hooks (1) as a pair from the catch mechanism and at the same time slightly raise the arcing chamber.
- ▶ Then release the second pair of snap-fit hooks (1) from the catch mechanism and remove the whole arcing chamber unit (2) (including the cover cap) upwards from the housing (3).

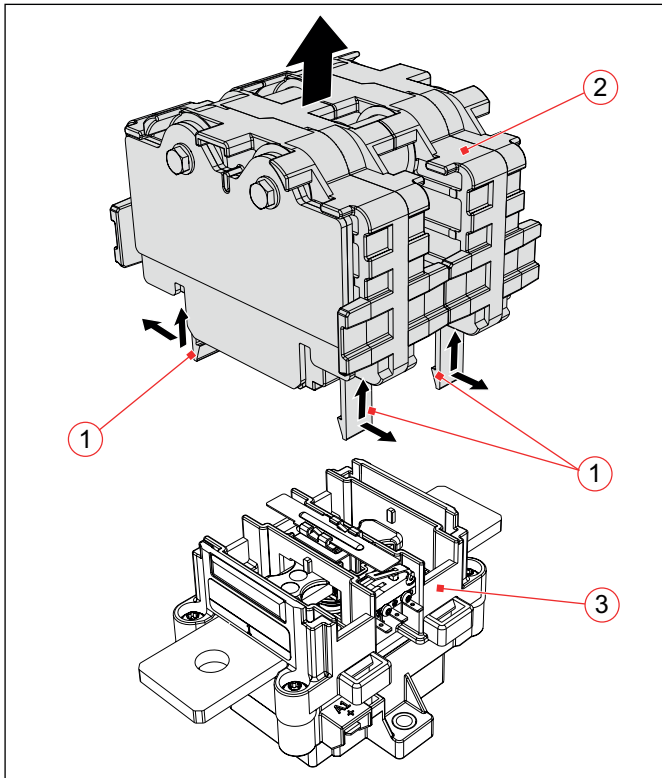

Fig. 21: C360K: Removing the arcing chamber unit

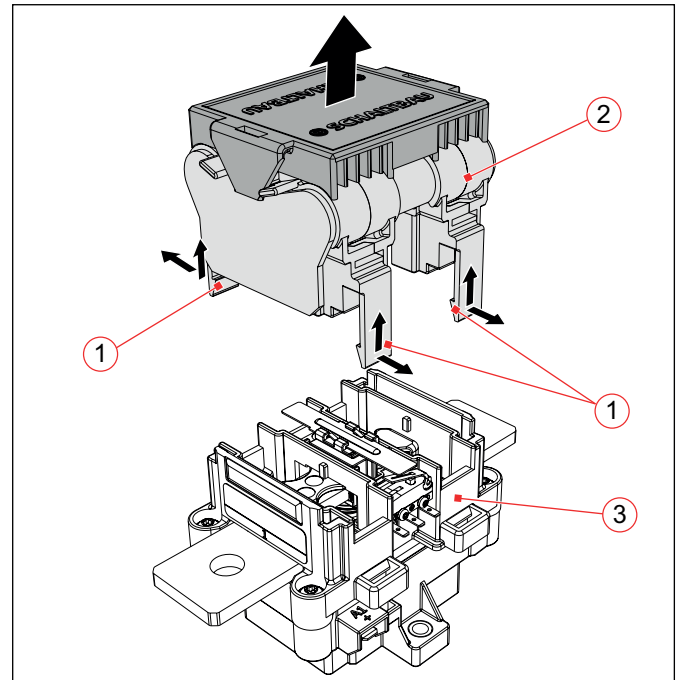

Fig. 22: C360A: Removing the arcing chamber unit

Removing the arcing chamber unit (C360S types)

- ▶ Either manually or using a screwdriver, release the opposing snap-fit hooks (1) as a pair from the catch mechanism and remove the arcing chamber (2) upward from the housing (3).
- ▶ Remove the second arcing chamber (2) in the same manner.

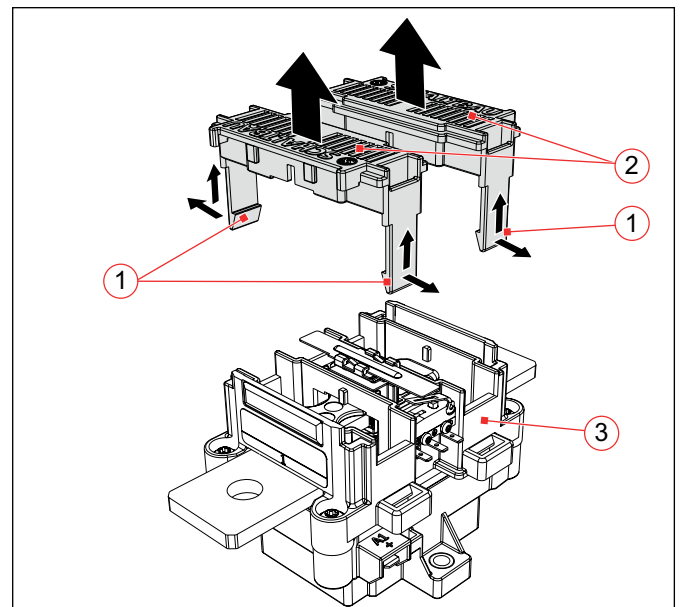

Fig. 23: C360S: Removing the arcing chambers

Inserting the arcing chambers

- ▶ Dependent on the type, reinsert the arcing chamber unit (2) or arcing chambers (2) in the mountings on the housing (3) of the contactor.
- ▶ In doing so, ensure that the snap-fit hooks (1) engage correctly in the housing (3).

Checking the arcing chambers (only with C360K and C360A types)

Requirements

- ▶ The arcing chamber unit must be removed from the contactor housing. See section “8.2 Preventive maintenance” / “Removing the arcing chambers”.

Tools required

- ▶ Vernier calliper, ruler

Checking the arcing chamber for wear

- ▶ Measure the four webs (4) of the arcing chambers on the underside of the arcing chamber unit.
- ▶ The contactor must be replaced no later than when the width of one of the 4 webs (4) is worn down to 1 mm residual thickness at the thinnest point.
- ▶ The option, replacement of the arcing chamber, is only available with C360A types. In this respect, see section “8.3 Corrective maintenance” / “Replacing the arcing chambers (only with C360A types)”.

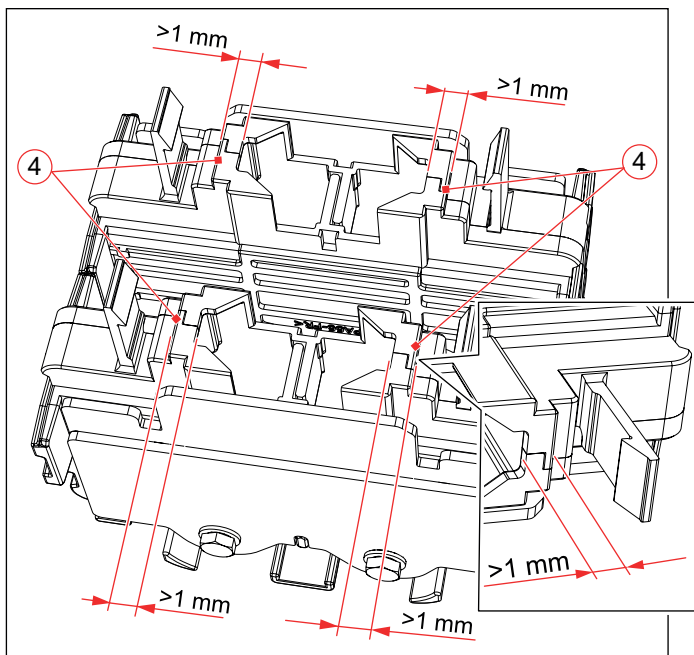

Fig. 24: C360K: the minimum width of the four webs (4) on the underside of the arcing chamber must be > 1 mm.

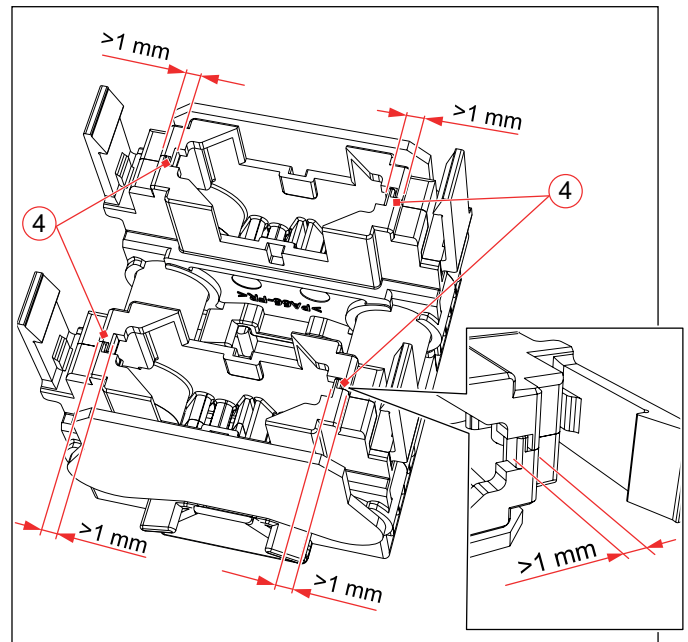

Fig. 25: C360A: the minimum width of the four webs (4) on the underside of the arcing chamber must be > 1 mm.



The width of the webs (4) has been optimised in respect of the material properties and the wear behaviour under the thermal loading of the electric arc and serves as an indicator for the overall arcing chamber wear.

Checking the main contacts

Requirements

- ▶ Dependent on the type, the arcing chambers must be removed from the contactor housing. See section *"Removing the arcing chambers"*.

Tools required

- ▶ Inspection mirror

Checking the main contacts for wear

- ▶ Check the main contacts using an inspection mirror. In doing so
 - check both the stationary contacts (5),
 - as well as the contacts (6) on the underside of the moving contact bridge.
- ▶ If more than 70% of the contact material is burnt through, replace the contactor as a whole unit.

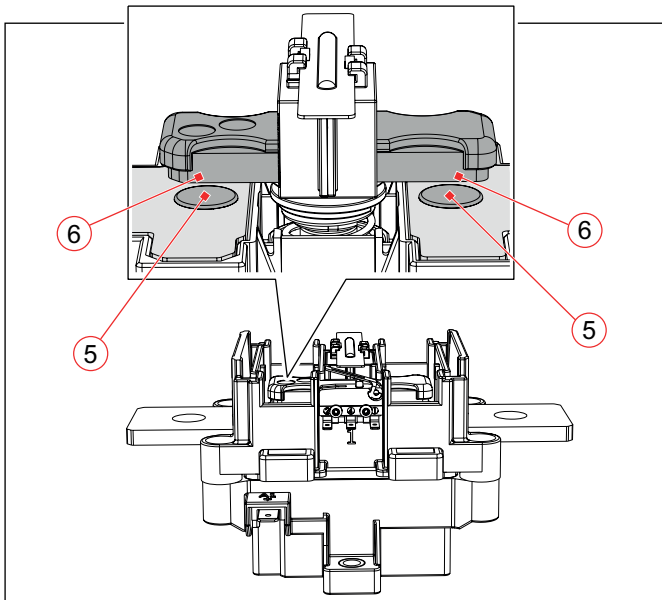

Fig. 26: Checking the main contacts for wear

Checking the contact bridge cover for wear

Dependent on the electrical load and the number of switching cycles, material is eroded from the contact bridge cover by the electric arc. Consequently the web between the two circular recesses (7) becomes ever thinner. The minimum residual width for the web is 5 mm.

- ▶ Measure the web width between the circular recesses (7).
- ▶ If the web width is less than 5 mm, replace the entire contactor.

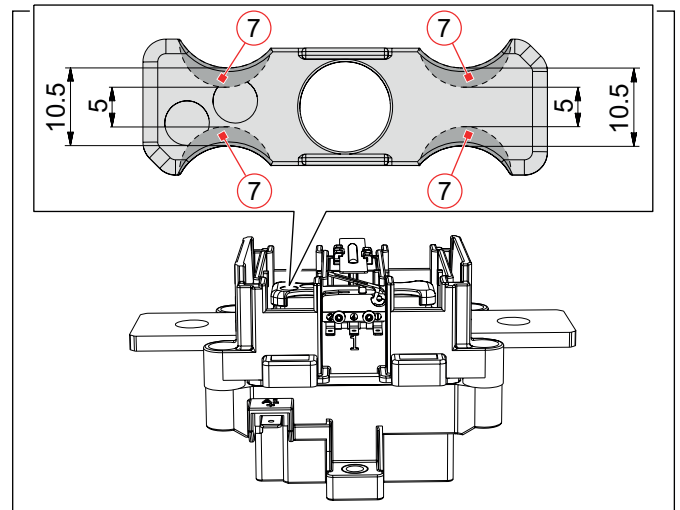

Fig. 27: The minimum residual width for the web of the contact bridge cover is 5 mm

8.3 Corrective maintenance

The contactors are largely maintenance-free. Therefore there is no general requirement to replace parts during its service life. Excepted from this are auxiliary switches and for C360A types only, the arcing chambers:

Replacing the S880 auxiliary switch

Under normal working condition (there have been no short circuits in the control circuit) the main switch must be replaced after no more than one million actuations in accordance with this manual.

However, in the event of a short circuit in the control circuit, it is possible that an auxiliary switch is damaged and must be replaced.

Tools required

- ▶ Set of Torx bits or Torx screwdrivers
- ▶ Torque wrench

Procedure

To secure the auxiliary switch, use only the original plastic-self-tapping screws 2 x 12, Torx drive 6 (T6) – do not use any screws with a standard/regular screw thread!

- ▶ Pull off the receptacles of the control wires from the auxiliary switch (1).
- ▶ Using the Torx tool (T6) screw out the two plastic-self-tapping screws (2) of the auxiliary switch and remove the auxiliary switch.
- ▶ Position a new auxiliary switch (1) on the mounting.
- ▶ Lightly screw in the two plastic-self-tapping screws (2).
- ▶ Check that the auxiliary switch (1) is level on the mounting and is not skewed.
- ▶ Tighten the two plastic-self-tapping screws (2) to a torque of 0.3 Nm.
- ▶ Plug the receptacles of the control wires back on to the contacts of the auxiliary switch (1).

If the auxiliary switch is being replaced, this must only be performed using an identically constructed switch.

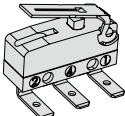
Auxiliary switch	Figure	Contactors type
S880 W1R6 k		C360A C360S C360K

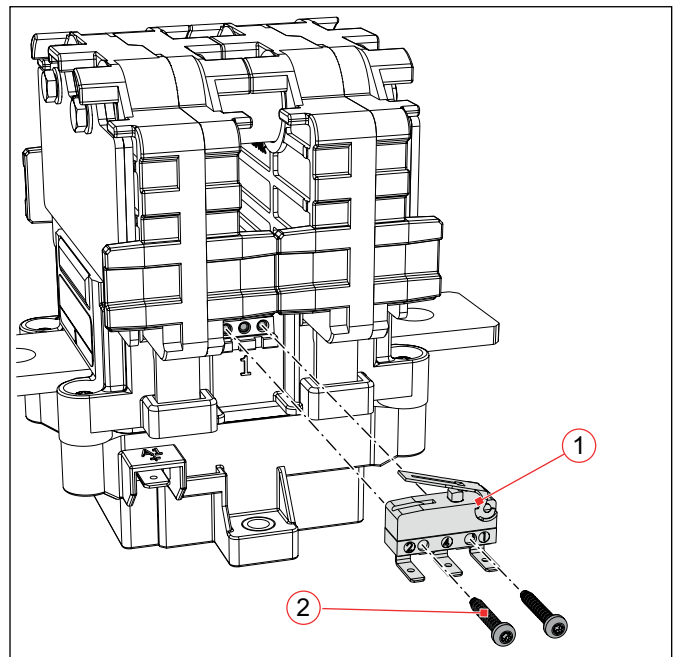

Fig. 28: C360K: Replacing the auxiliary switch

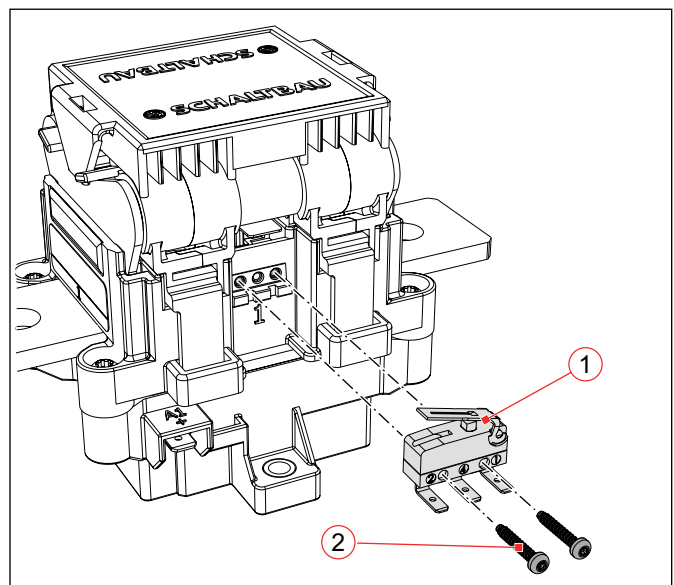

Fig. 29: C360A: Replacing the auxiliary switch

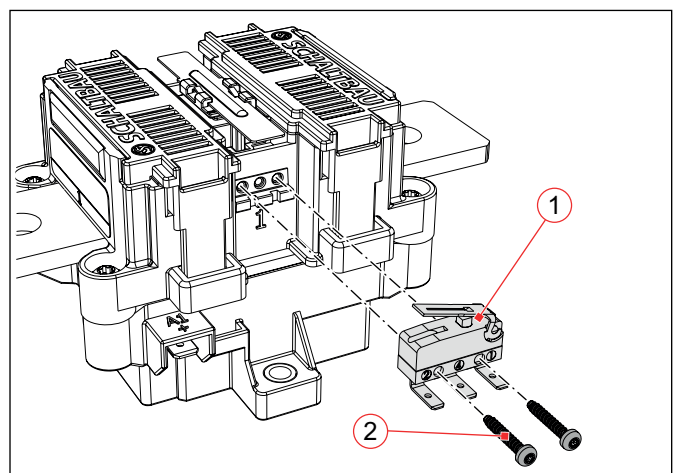

Fig. 30: C360S: Replacing the auxiliary switch

Replacing the arcing chambers (only with C360A types)

Requirements

- ▶ The arcing chamber unit must be removed from the contactor housing. See section "8.2 Preventive maintenance" / "Removing the arcing chambers".

Tools required

- ▶ Set of flat bladed screwdrivers
- ▶ Magnetic pole detector to determine the magnetic pole

Procedure

- ▶ Insert a suitable flat bladed screwdriver in the rectangular opening (1) of the cover cap (2) and undo the snap-fit hooks.
- ▶ Remove the cover cap (2).

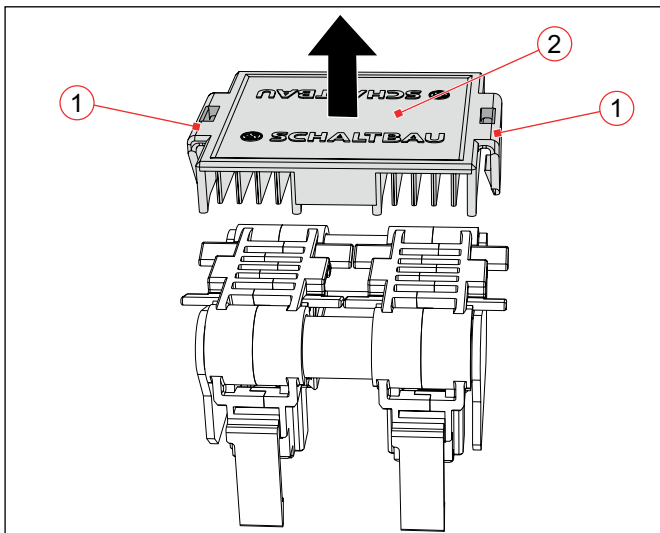

Fig. 31: Removing the cover cap

- ▶ Release a pole strip (3) by tilting the arcing chamber unit.

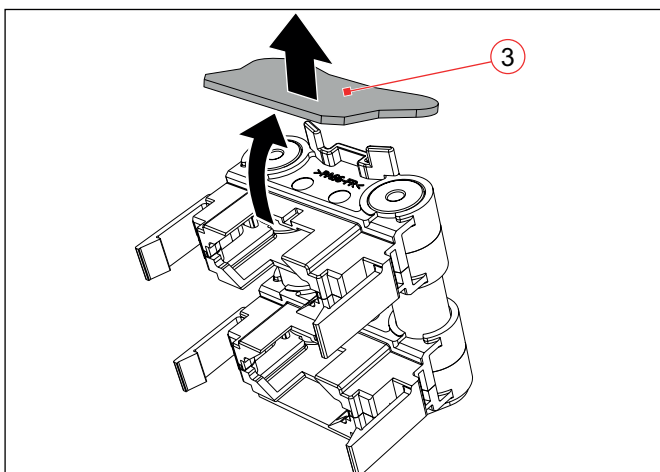

Fig. 32: Tilting and removing a pole strip

- ▶ Pull off both arcing chambers (4) from the magnetic cores (5).

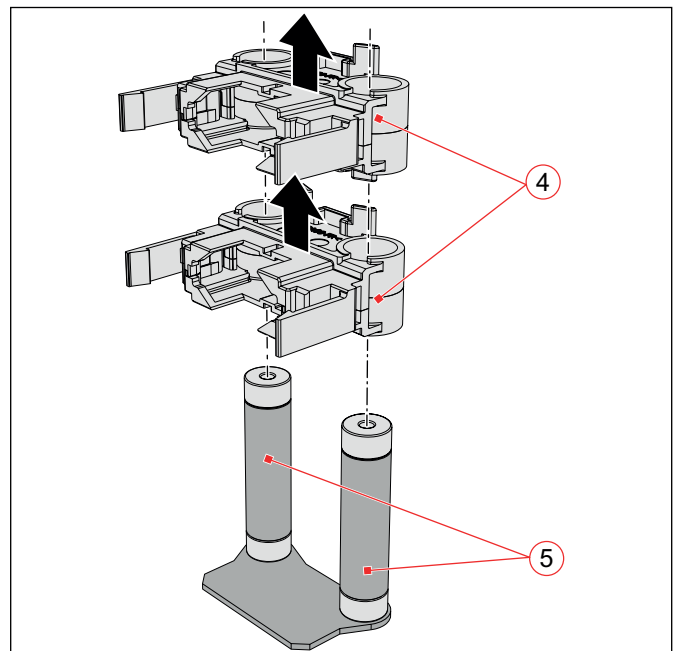

Fig. 33: Pulling the arcing chambers away from the magnetic cores

ATTENTION

- ▶ Do not release or push the magnetic cores from the second pole strip.
- ▶ Do not further dismantle the part arrangement shown below because there is a very high risk of positioning the magnetic cores incorrectly.
- ▶ It is important that the magnetic alignment of both magnetic cores is the same. It does not matter whether the north or south pole is at the top or bottom. See Fig. 34.
- ▶ In case of doubt, use a magnetic pole finder to determine the correct magnetic direction of the magnetic cores according to Fig. 34.

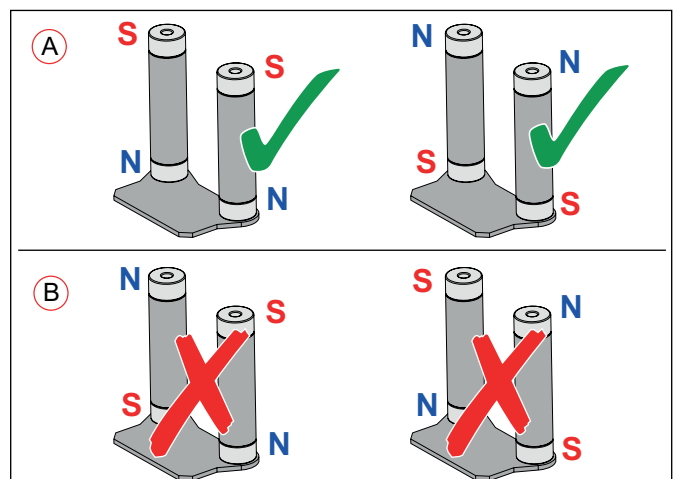

Fig. 34: Permissible alignment (A) and impermissible alignment (B) of the poles of the magnetic cores.

- ▶ Push new arcing chambers (4) on to the magnetic cores (5).
- ▶ Position the pole strip (3) on the solenoid cores (5) and attach to the arcing chamber unit by tilting.
- ▶ Check whether the pole strip (3) and arcing chambers are correctly aligned.
The arcing chambers (4) and arcing strip (3) must lie flush against each other.
- ▶ If necessary, readjust the pole strip (3) and arcing chambers (4).
- ▶ Position the cover cap (2) push home firmly.
- ▶ In doing so, ensure that the snap-fit hooks engage correctly.
- ▶ Check all parts of the arcing chamber unit for correct and tight seating.

9. Spare parts



Important!

When ordering spare parts, always specify the precise type and article number of the contactor. You can find this data on the rating plate.

Designation

- Arcing chamber C360A
- Auxiliary switch type S880 W1R6 k *

* If the auxiliary switch is being replaced, this must only be performed using an identically constructed switch.

10. Technical data

Technical data and information on the material properties for the contactors of the C360 series are given in our *C360 catalogue*.

Schaltbau products are subject to continual improvement. Therefore, the product information in catalogues, data sheets, etc. may change at any time. Therefore, only the latest version of a catalogue is valid at any time – downloads available under:

https://www.schaltbau.com/media/c360_en.pdf

11. Disposal

This product is designed for exclusive professional use by commercial companies. The owner is responsible for ensuring an environmentally sound disposal of this product at the end of its working life.

This product or parts of it may not be disposed of with other household waste.

To prevent possible harm to the environment or human health from uncontrolled waste disposal, please separate this product or parts of it from other types of wastes and recycle it responsibly to promote the sustainable reuse of material resources.

Please observe all local regulations and recommendations for the disposal, recycling or environmentally friendly processing of the parts and materials that have been used or replaced during installation, operation, and maintenance tasks.

At the end of the product's useful life ensure environmentally sound disposal of the product according to the legal regulations and requirements for electrical and electronic waste equipment in your country.

Schaltbau GmbH

For detailed information on our products and services visit our website – or give us a call!

Schaltbau GmbH
Hollerithstrasse 5
81829 Munich
Germany



Phone +49 89 9 30 05-0
Fax +49 89 9 30 05-350
Internet www.schaltbau.com
e-Mail contact@schaltbau.de

with compliments:



The production facilities of Schaltbau GmbH have been IRIS certified since 2008.



Certified to DIN EN ISO 14001 since 2002. For the most recent certificate visit our website.



Certified to DIN EN ISO 9001 since 1994. For the most recent certificate visit our website.

Electrical Components and Systems for Railway Engineering and Industrial Applications

Connectors

- Connectors manufactured to industry standards
- Connectors to suit the special requirements of communications engineering (MIL connectors)
- Charging connectors for battery-powered machines and systems
- Connectors for railway engineering, including UIC connectors
- Special connectors to suit customer requirements

Snap-action switches

- Snap-action switches with positive opening operation
- Snap-action switches with self-cleaning contacts
- Snap-action switch made of robust polyetherimide (PEI)
- Snap-action switch with two galvanically isolated contact bridges
- Special switches to suit customer requirements

Contactors Emergency disconnect switches

- Single and multi-pole DC contactors
- High-voltage AC/DC contactors
- Contactors for battery powered vehicles and power supplies
- Contactors for railway applications
- Terminal bolts and fuse holders
- DC emergency disconnect switches
- Special contactors to suit customer requirements

Electrics for rolling stock

- Equipment for driver's cab
- Equipment for passenger use
- High-voltage switchgear
- High-voltage heaters
- High-voltage roof equipment
- Equipment for electric brakes
- Design and engineering of train electrics to customer requirements