

3

Contactors

C320 series

**1 pole bi-directional DC
NO contactors for
1,000 amps**

Catalogue C320.en

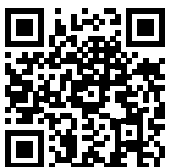

More information
schaltbau.com

C320 – 1 pole bi-directional DC NO contactors

Compact single-pole NO contactors for DC up to 1,800 volts rated insulation voltage. Making current up to 3,000 amps; conventional thermal current up to 1,000 amps; short-time current up to 4,500 amps.

The bidirectional DC contactors of the C320 series extend the application range of the successful C310 and C360 series. The compact devices switch even higher powers. With a rated short-circuit breaking capacity of up to 3,000 amps, the contactors are suitable for applications with high inrush currents. The devices can permanently conduct up to 1,000 amps – thanks to high contact forces with measurably less heating in the main contact

system. In the event of a short circuit, as much as 4,500 amps may flow for one second without the contacts welding. This means that the contactor retains its full function in order to disconnect large powers when required, regardless of the direction of the current. This excellent breaking capacity is made possible by an efficient ceramic arc chamber with generously dimensioned air gaps.

Features

C320 series

- Compact dimensions – high rated insulation voltage U_i up to 1,800 volts**
All air clearances in the contact area are generously dimensioned. The rated insulation voltage is 1,800 volts. The C320K/1000 is specified for rated operational voltages up to 1,500 volts. The C320S/1000 is suitable for rated operational voltages up to 60 volts and is significantly more compact.
- High thermal continuous current I_{th} up to 1,000 amps**
All versions of the C320 can carry up to 1,000 amps permanently. In addition, the series has a very high short-time current carrying capacity I_{cw} up to a maximum of 4,500 amps. These values are achieved by optimised silver contacts, high contact forces and permanently extremely low contact resistances.
- High making capacity I_{cm} up to 3,000 amps and an excellent breaking capacity**
The C320 can switch on a current of up to 3,000 amps. A PWM controller regulates the coil current, ensures low-bounce switch-on and low holding power. The C320K/1000 handles high short-circuit currents and can switch off a current of 800 amps at 1,500 volts, for example. An efficient ceramic arc chamber makes this very good breaking capacity possible.
- Low energy consumption and low heating thanks to sophisticated coil saving circuit**
A PWM controller regulates the pull-in and holding current. This ensures a low-bounce switch-on, limits the power consumption in holding mode and significantly reduces the heating of the coil. In addition to flexible and power-saving control, this also increases the service life.
- Full bidirectionality – safe disconnection of high powers**
All versions of the C320 can reliably disconnect high currents and voltages, irrespective of the current direction. In the C320K/1000, these properties are achieved by the special arrangement of the blowout magnets and arc chamber as well as generously dimensioned air clearances in the contact area.
- Auxiliary switches with mirror contact function**
The C320 contactors can be equipped with up to four auxiliary switches, of which a maximum of two auxiliary switches can have mirror contact function according to IEC 60947-4-1, Annex F. Mirror contacts are required for the feedback circuits in safety controls. The mirror contact function means that the NC contact of the auxiliary contact cannot and must not be closed at the same time as the NO main contact.

Standards

C320 series

Contactors meet requirements for industrial applications to:

- IEC 60947-4-1**
Low-voltage switchgear and controlgear – Part 4-1: Contactors and motor starters – Electromechanical contactors and motor starters.
- ISO 16750-3**
Road vehicles – Environmental conditions and testing for electrical and electronic equipment – Part 3: Mechanical loads
- UL 60947-4-1**
Low-Voltage Switchgear and Controlgear – Part 4-1: Contactors and Motor-Starters – Electromechanical Contactors and Motor-Starters.
- GB/T 14048.4**
Low-Voltage Switchgear and Controlgear – Part 4-1: Contactors and Motor-Starters – Electromechanical Contactors and Motor-Starters.

Contactors meet requirements for railway applications to:

- IEC 60077-2**
Railway applications – Electric equipment for rolling stock – Part 2: Electrotechnical components; General rules
- IEC 61373**
Railway applications – Rolling stock equipment – Shock and vibration tests
- IEC 62497-1**
Railway applications – Insulation coordination – Part 1: Basic requirements – Clearances and creepage distances for all electrical and electronic equipment

Reliable, robust and economical

C320 series

Contactors of the C320 series are designed for continuous currents of 1,000 amps. The switchgear has both high making and breaking capacities, and a high short-time withstand current. This ensures high operational safety.

An integrated electronic coil control ensures constantly reliable switching behaviour independent of the ambient temperature. In addition, the energy consumption and associated heat development is noticeably reduced when switched on.

Depending on the application, high demands are placed on electro-mechanical components. The new DC contactors are highly resistant to shock and vibration loads and meet the high requirements of ISO 16750-3 as well as those of IEC 61373.

Ordering key

C320 series

Example: **C320K/1000 24E-BBBB**

Series, contact configuration		Auxiliary switches, number / type	
C320	1 pole NO contactor, DC bi-directional	Position (see page 6)	
Version		Snap-action switches S870 W1D1 t	
K	1,500 V DC	1	2*
S	60 V DC	3	4*
Conv. thermal current		Coil design	
1000	$I_{th} = 1,000 \text{ A}$	Monostable with integrated PWM module	
Coil voltage		E	
24	$U_s = 24 \text{ V DC}$ Operating range 16 ... 36 V DC		

Note:
* with mirror contact function according to IEC 60947-4-1, annex F

Presented in this catalogue are only stock items which can be supplied in short delivery time. For some variants minimum quantities apply. Please do not hesitate to ask for the conditions.

Special variants:
If you need a special variant of the contactor, please do not hesitate to contact us. Maybe the type of contactor you are looking for is among our many special designs. If not, we can also supply customized designs. In this case, however, minimum order quantities apply.

Applications

C320 series

Thanks to many years of experience and competence in developing electromechanical switchgear and the mastering DC arcs, Schaltbau has developed an innovative solution with new DC contactors that significantly simplifies applications with DC switching technology. Since the C320 series safely controls both current directions, the contactors are ideal for all applications involving energy recovery.

Typical applications are the use as main contactor in battery management systems of high-voltage vehicle batteries, in charging stations for e-mobility, in battery test stands, in DC circuits of inverters for photovoltaic systems or in rail vehicles as main contactor in traction and auxiliary converters or as isolating contactor in battery circuits.



E-mobility

- Electrical vehicles, hybrid vehicles and trolley busses
- DC charging station
- Battery test system



Battery energy storage systems

- Grid stabilization and battery energy storages
- Regenerative systems in industrial plants
- Battery management systems
- Industrial energy storage systems



Rail vehicles

- Traction contactors for battery or hybrid vehicles
- Contactors for auxiliary converters for battery or hybrid vehicles
- Isolating contactors in battery circuits



Photovoltaics

- DC switching in central inverters
- Electrical cabinet (combiner boxes)
- Industrial energy storage systems

Specifications C320K/1000 for $U_e = 1,500$ V DC, C320S/1000 for $U_e = 60$ V DC

C320 series

Series	C320K/1000	C320S/1000
Type of voltage	DC, bi-direktional / AC, $f \leq 60$ Hz	
Main contacts, configuration	1x NO	
Electrical data according to IEC/UL 60947-4-1, GB/T 14048.4		
Rated operational voltage U_e	1,500 V	60 V
Rated insulation voltage U_i	1,800 V	1,800 V
Rated impulse withstand voltage U_{imp}	10 kV	10 kV
Pollution degree / Overvoltage category	PD3 / OV3	
Conventional free air thermal current I_{th}	$T_a = 60^\circ$ C (cross section)	1,000 A
Power dissipation per pole I_{th}	typ.	50 W
Pole impedance	typ.	50 $\mu\Omega$
Utilization category DC-1	IEC 60947-4-1, GB/T 14048.4	
Rated operational current I_e	150 A @ $U_e = 1,500$ V DC	330 A @ $U_e = 48$ V DC
Utilization category DC-1 / DC general use	UL 60947-4-1	
Rated operational current I_e	80 A @ $U_e = 1,500$ V DC	330 A @ $U_e = 48$ V DC
Frequency of operation (operations per hour) I_e	DC-1	180 h ⁻¹
Rated short-time withstand current I_{cw}	t = 100 ms	4,500 A
Additional electrical ratings of main circuit		
Conventional free air thermal current I_{th}	$T_a = 60^\circ$ C (cross section) Terminal heating	1,000 A (600 mm ²) 55 K
Rated short-circuit making capacity I_{cm}	(L/R = 0 ms)	3,000 A
Breaking capacity / UL special use ratings	$U_e = 1,500$ V / $I_e = 800$ A / L/R = 0.15 ms $U_e = 1,500$ V / $I_e = 450$ A / L/R = 1 ms $U_e = 1,000$ V / $I_e = 1,600$ A / L/R = 0.2 ms $U_e = 1,000$ V / $I_e = 1,300$ A / L/R = 1 ms	30 operations 30 operations 30 operations 30 operations
Breaking capacity	$U_e = 60$ V / $I_e = 2,200$ A / L/R = 1 ms	---
Electrical endurance	$U_e = 1,250$ V DC / $I_e = 120$ A / L/R = 1 ms $U_e = 60$ V DC / $I_e = 500$ A / L/R = 1 ms	6,000 operations ---
Critical current range	None	None
Main contacts		
Contact material	AgSnO ₂	
Terminals	2x M8	
Torque	6 ... 8 Nm	
Auxiliary contacts		
Number, configuration / contact material	4 max. snap-action switches S870 W1D1 t / silver	
Making / breaking capacity	Snap-action switch S870	AC-15: 230 V AC / 1.5 A DC-13: 60 V DC / 0.5 A
Minimum voltage / current	24 V / 5 mA	
Terminals	Flat tabs 6.3 x 0.8 mm	
Magnetic drive (monostable)		
Rated control supply voltage U_s (Operating range)	24 V DC (16 ... 36 V DC)	
Pollution degree / Overvoltage category	PD3 / OV2	
Coil power dissipation, max. ($T_a = 20^\circ$ C / U_s)	Pull-in (0.2 s) / Holding power	95 W (24 V) / 11 W
Frequency of operation (operations per hour, no load)	$T_a = 20^\circ$ C / 60° C	3,600 h ⁻¹ / 1,800 h ⁻¹
Pull-in time ($T_a = 20^\circ$ C / U_s) / Drop-off time ($T_a = 20^\circ$ C / U_s)	typ.	< 60 ms* / < 10 ms
Coil suppression	integrated	
Coil terminals	2-pole screwless terminal block for solid and stranded conductors up to 2.5 mm ² max.	
Mounting position		
Degree of protection	IEC 60529	IP00
Mechanical endurance		
1,000,000 operations		
Vibration		
IEC 61373 / ISO 16750-3 Category 1, class B / profile VII		
Shock		
IEC 61373 / ISO 16750-3 Category 1, class B / 20 g/6 ms		
Temperatures		
Operating temperature / Storage temperature Altitude** / Humidity (IEC 62498-1)		
-40 °C ... +60 °C / -40 °C ... +85 °C < 5,000 m above sea level / < 75 % rel. humidity, annual average		
Weight		
2.7 kg		
2.0 kg		

* Detection of the switching status via the auxiliary contacts from 120 ms onwards

** Greater warming is possible for altitudes $\geq 2,000$ m a.s.l.

Dimension diagram C320K/1000, C320S/1000

Baureihe C320

• **Dimension diagram C320K/1000:**

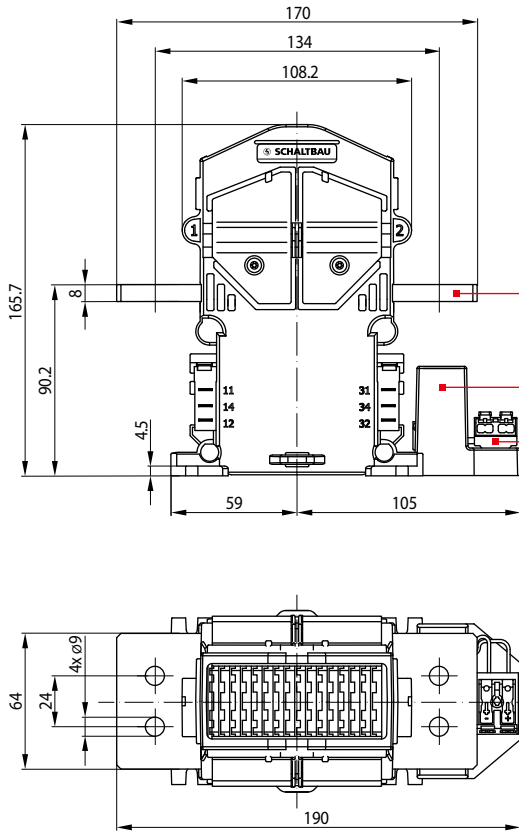

Arc chamber main contact system
Highly efficient ceramic arc chamber with permanent magnetic blowout

Main contact terminals
Holes for bolts M8,
Tightening torque 6 ... 8 Nm

Auxiliary switches
2x or 4x snap-action switches S870, SPDT,
flat tab 6.3 x 0.8 mm

Electronic coil controller
Permanently reliable switching behaviour
regardless of ambient temperature, reduced
energy consumption and less heat generation

Coil terminal
2 pole screwless terminal block for
solid and stranded conductors
up to 2.5 mm² max.

• **Dimension diagram C320S/1000:**

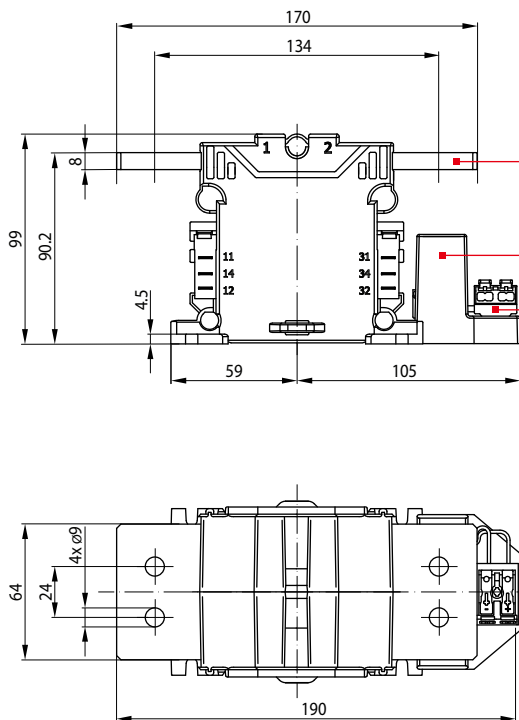

Main contact terminals
Holes for bolts M8,
Tightening torque 6 ... 8 Nm

Auxiliary switches
2x or 4x snap-action switches S870, SPDT,
flat tab 6.3 x 0.8 mm

Electronic coil controller
Permanently reliable switching behaviour
regardless of ambient temperature, reduced
energy consumption and less heat generation

Coil terminal
2 pole screwless terminal block for
solid and stranded conductors
up to 2.5 mm² max.

Minimum distances to magnetically active, live or earthed parts

C320 series

• C320K/1000

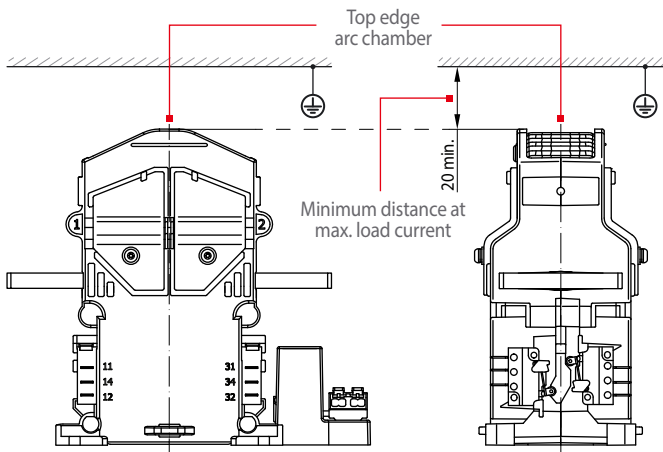

• C320S/1000

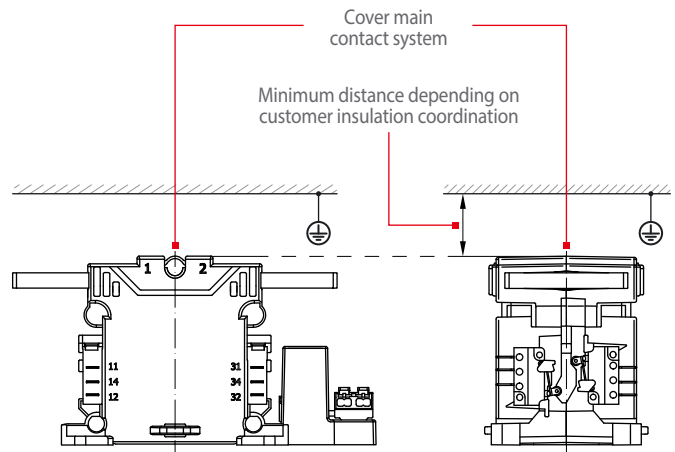

Circuit diagram

C320 series

• C320K/1000

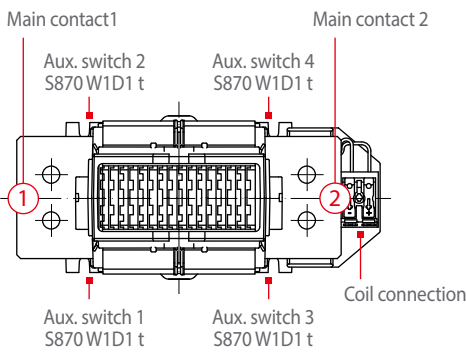

• C320S/1000

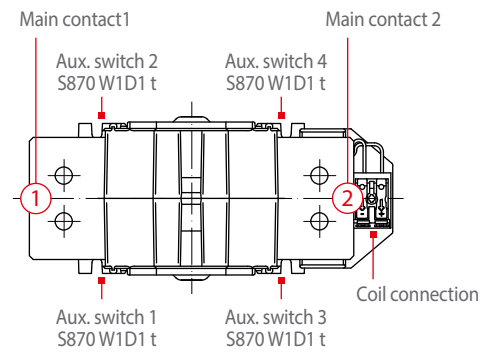

• Circuit diagram

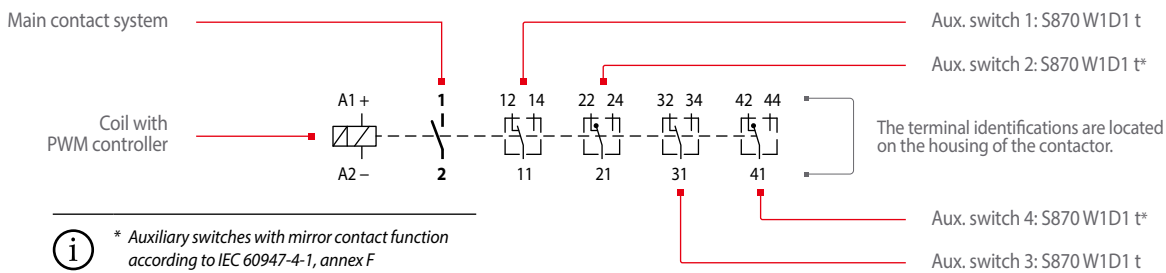

i * Auxiliary switches with mirror contact function according to IEC 60947-4-1, annex F

Mounting holes

C320 series

• C320K/1000, C320S/1000

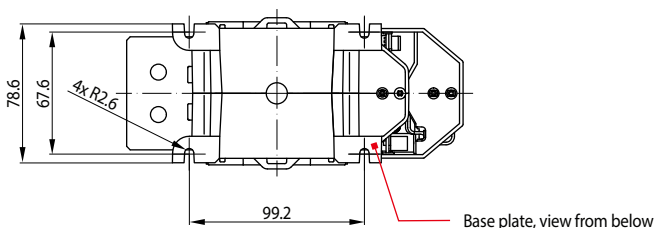

i The contactors are mounted on a suitable mounting plate with four M5 screws.

Mounting instructions

C320 series

• C320K/1000

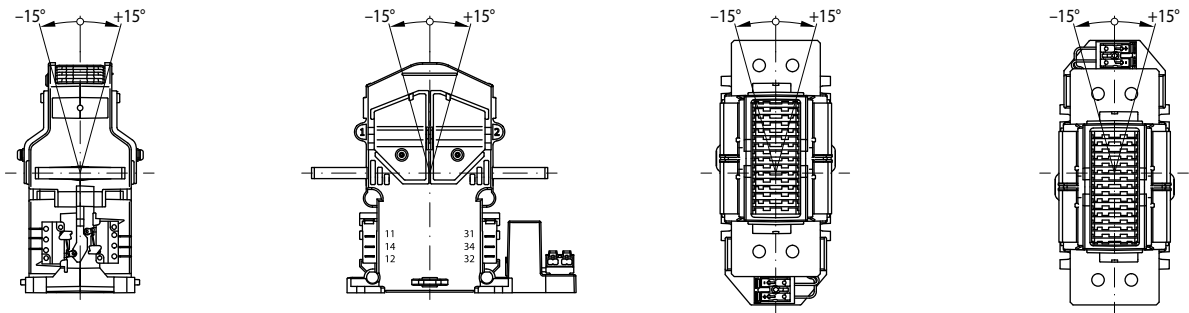

• C320K/1000

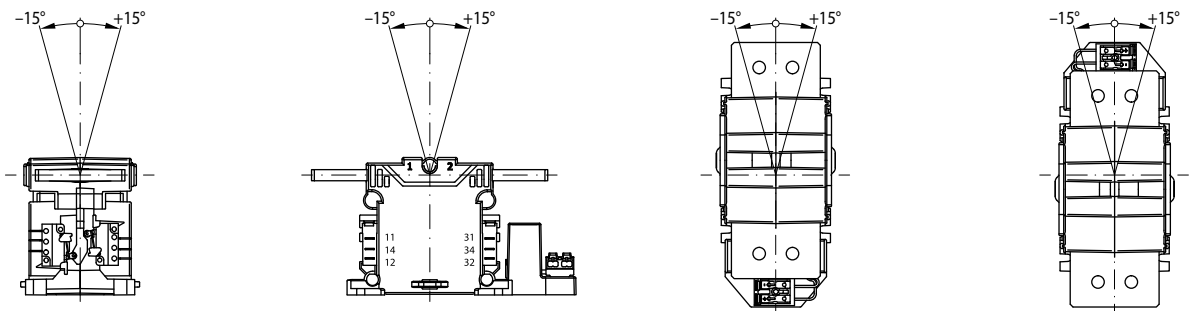

Horizontal assembly
«Table mounting»

Vertical assembly
«Wall mounting»



The contactors can be mounted horizontally or vertically on a prepared mounting plate. Mounting positions hanging upside down are not allowed!

Maintenance and safety instructions

C320 series

Maintenance:

- C320 series contactors are basically maintenance free.
- Make regular in-depth visual inspections once or twice a year.

Safety instructions:

- The device must be used according to the intended purpose as specified in the technical documentation. You are obliged to observe all specifications depending on operating temperature, degree of pollution etc. that are relevant to your application.
- Without further safety measures the contactors are not suited for use in potentially explosive atmospheres.
- In case of malfunction of the device or uncertainties stop using it any longer and contact the manufacturer instantly.
- Tampering with the device can seriously affect the safety of people and equipment. This is not permitted and leads to an exclusion of liability and warranty.
- Coil suppression for reducing surges when the coil is switched off is optimally attuned to the contactors switching behaviour. The existing opening characteristic must not be negatively influenced by parallel connection with an external diode.
- Contactors running permanently may heat up. So make sure that the contactor has sufficiently cooled down before you start any inspection or maintenance work.



For detailed maintenance, safety and mounting instructions please refer to our operating manuals
 ➔ [C320-M.en!](#)

- When installing contactors with magnetic blowout make sure to do it in such a way that no magnetizable parts can be attracted by the permanent magnets that are also capable of destroying all data of swipe cards.
- In general, strong electromagnetic fields can be generated in the area around the contactors. These can influence other components in the area of the contactors.
- Improper handling of the contactor, e.g. when hitting the floor with some impact, can result in breakage, visible cracks and deformation.



Defective contactors or parts (e.g. arc chambers, auxiliary switches) must be replaced immediately!



For a detailed list of all safety instructions see here:
 ➔ schaltbau.info/safety3en!

Schaltbau GmbH

For detailed information on our products and services visit our website – or give us a call!

Schaltbau GmbH
Hollerithstrasse 5
81829 Munich
Germany



Phone +49 89 9 30 05-0
Fax +49 89 9 30 05-350
Internet www.schaltbau.com
e-Mail contact@schaltbau.de



The production facilities of Schaltbau GmbH have been IRIS certified since 2008.



Certified to DIN EN ISO 14001 since 2002. For the most recent certificate visit our website.



Certified to DIN EN ISO 9001 since 1994. For the most recent certificate visit our website.

Electrical Components and Systems for Railway Engineering and Industrial Applications

Connectors

- Connectors manufactured to industry standards
- Connectors to suit the special requirements of communications engineering (MIL connectors)
- Charging connectors for battery-powered machines and systems
- Connectors for railway engineering, including UIC connectors
- Special connectors to suit customer requirements

Snap-action switches

- Snap-action switches with positive opening operation
- Snap-action switches with self-cleaning contacts
- Snap-action switch made of robust polyetherimide (PEI)
- Snap-action switch with two galvanically isolated contact bridges
- Special switches to suit customer requirements

Contactors Emergency disconnect switches

- Single and multi-pole DC contactors
- High-voltage AC/DC contactors
- Contactors for battery powered vehicles and power supplies
- Contactors for railway applications
- Terminal bolts and fuse holders
- DC emergency disconnect switches
- Special contactors to suit customer requirements

Electrics for rolling stock

- Equipment for driver's cab
- Equipment for passenger use
- High-voltage switchgear
- High-voltage heaters
- High-voltage roof equipment
- Equipment for electric brakes
- Design and engineering of train electrics to customer requirements