

3

Contactors

C320 series

1 pole
AC and bi-directional DC
NO contactors for 1,000 A

Installation and
maintenance instructions

Manual C320-M.en



Document Revision History

Date	Rev. version	Description	Pages
2021-07-15	V1.0	Initial version	All

Content

1. Important basic information	4
1.1 Legal notes	4
1.2 Conventions for this manual	4
2. General and safety information	4
2.1 Observing the manual	4
2.2 Duties of the operating company	5
2.3 Intended use	5
2.4 Ambient conditions	5
3. Hazards and safety precautions	6
3.1 Electrical hazards	6
3.2 Other hazards	6
3.3 Measures for avoiding damage and malfunctions	7
4. Product information	8
4.1 C320 – 1 pole bi-directional DC NO contactors	8
4.2 Technical information and material properties	8
4.3 Overview	9
C320K/1000	9
C320S/1000	10
5. Storage	11
6. Unpacking	11
6.1 Unpacking the device	11
6.2 Check parts for transport damage	11
7. Installation	12
7.1 Mounting	12
Dimensions/interfaces and further technical specifications	12
Preparatory measures	12
Mounting holes	12
Mounting positions	13
Required minimum clearances	13
Ventilation requirements	14
Safety	14
Tools required	14
Installing the contactor	14

7.2	Electrical connection	15
	Electrical data and other technical specifications.....	15
	Preparatory measures.....	15
	Safety	16
	Tools required.....	16
	Connecting the S870 auxiliary switches.....	17
	Connecting the coil.....	18
	Connecting the main contacts.....	19
7.3	Checks	21
8.	Maintenance	22
8.1	Safety	22
8.2	Preventive maintenance.....	22
	Intervals for regular tests/checks	22
	Regular tests/checks	23
	Checking the main contacts	24
8.3	Corrective maintenance	25
	Replacing the S870 auxiliary switches.....	25
9.	Spare parts	27
10.	Technical data.....	27
11.	Disposal	27

1. Important basic information

1.1 Legal notes

Without prior written consent of SCHALTBAU GmbH, this manual is not allowed to be electronically or mechanically reproduced – as a whole or in parts – be distributed, changed, transmitted, translated into another language or used in any other way.

SCHALTBAU GmbH cannot be held liable for damage caused by non- or only partial observation of the manual.

1.2 Conventions for this manual

This manual describes the installation and maintenance of the contactors.

Cross references are presented in *bold italics*.

To highlight particularly important safety instructions and other information, the following symbols are used in this manual:

⚠ DANGER
Indicates a directly threatening dangerous situation. Death or severe injuries will result if it is not prevented.

⚠ WARNING
Indicates a possibly dangerous situation. Death or severe injuries may result if it is not prevented.

⚠ CAUTION
Indicates a possibly dangerous situation. Medium or minor injuries may result if it is not prevented.

2. General and safety information

The contactors dealt with in this document are intended for use with electrical systems for special applications. They are designed and tested in compliance with generally accepted codes of practice. However, improper use, operation, handling, maintenance of or tampering with electric equipment can cause serious or fatal injury to the user or others, and the appliance or other property can be damaged. Consequently, the operation, maintenance and installation instructions for the contactors must be strictly followed.

If anything is not clear, clarification must be sought with any queries stating the device type and the serial number.

Only authorised and trained personnel are allowed to plan and carry out all mechanical and electrical instal-

ATTENTION
Indicates a possibly detrimental situation. If it is not prevented, assemblies, the system or property in its surroundings could be damaged.

	Indicates technical features and methods to simplify working or indicates information of particular importance.
---	---

This manual describes single pole contactors of the following types:

- C320K/1000
- C320S/1000

lations, transport, commissioning, as well as maintenance and repair work.

This applies to the observation of the general installation and safety regulations for electrical systems as well as the proper use of tools approved for this purpose. Electrical equipment requires protection from moisture and dust during installation, operation and storage.

2.1 Observing the manual

- ▶ All personnel must read and understand the instructions in this manual and adhere to them when working with the device.
- ▶ **Always adhere strictly to all safety instructions!**

2.2 Duties of the operating company

- ▶ Observe all applicable national regulations, all safety, accident prevention and environmental protection regulations as well as the recognised technical rules for safe and correct working.
- ▶ Regularly check all fitted protection and safety equipment for correct function.
- ▶ Work on electrical equipment must only be carried out by a qualified electrician or by instructed persons under the supervision and control of a qualified electrician in accordance with electrical regulations.
- ▶ A specialist is someone who, on the basis of their technical training, knowledge and experience as well as knowledge of the relevant regulations, is able to assess the work assigned to them and identify possible dangers.
- ▶ Work on the contactors must only be carried out by personnel who meet the requirements set out in this manual.
- ▶ Personnel must be clearly informed about who is responsible for the maintenance of the contactors.
- ▶ Always perform complete checks after any installation work and/or after any other conversions, alterations or maintenance, in accordance with the following standards:
 - EN/IEC 60077-2
 - EN/IEC 60947-4-1

2.3 Intended use

- ▶ The contactors have been designed and tested according to national and international standards. Due to their unique features they can also be used in a wide range of industrial applications.
- ▶ The contactors must only be used under operating conditions according to the technical specifications and the instructions in this manual.
- ▶ None of the conditions of use, such as voltages, currents or ambient conditions, defined in the corresponding technical data sheets or in our **C320 catalogue** may be overridden. The **C320 catalogue** is available under: https://www.schaltbau.com/media/C320_en.pdf
- ▶ The contactors may only be used when all protective devices are present, have been correctly installed and are fully operational.
- ▶ Contactors may not be used without other safety precautions in potentially explosive atmospheres and/or in aggressive media.

- ▶ The device contains unprotected live parts.
- ▶ The prescribed clearances relative to other live parts or earth and other parts must be complied with as well as the safety regulations of the applicable standards.
- ▶ Switching at close to the maximum breaking capacity may require increased minimum clearances! Do not hesitate to ask our advice in respect of any dimensioning.
- ▶ Coil suppression for reducing surges when the coil is switched off is optimally attuned to the contactor's switching behaviour. The existing opening characteristic must not be negatively influenced by parallel connection with an external diode.
- ▶ Improper handling of the contactors, e.g. impacts on the floor, may result in breakage, cracks or deformation. Always handle the device with care.
- ▶ Only use the contactors for the specified application and only with original parts. Any other usage of or tampering with the contactors is considered contrary to their intended use. No liability is assumed for damages and accidents caused due to non-compliance with the instructions in this manual or improper use of the contactors.

2.4 Ambient conditions

ATTENTION

The contactors have been design for specific ambient conditions.

- ▶ Only operate the contactors in ambient conditions, such as temperature ranges, degree of soiling, etc., as defined in the corresponding data sheets and in our **catalogue C320**. The **C320 catalogue** is available under: https://www.schaltbau.com/media/C320_en.pdf

3. Hazards and safety precautions

3.1 Electrical hazards

	<p>⚠ DANGER</p>
	<p>The contactors are used for high voltage switching. Contact with live electrical parts can result in serious injuries or even death! Live parts are all metal parts belonging directly to one of the circuits or wires connecting to them. All other visible metal parts and wiring may also be live if a fault exists. Before starting any work on the contactors, always comply with the following safety rules:</p> <ul style="list-style-type: none"> ▶ Disconnect on all sides ▶ Secure to prevent switching back on ▶ Clearly identify the working area ▶ Check that a voltage-free state exists ▶ Earth and short circuit; this includes discharging any capacitors in the main circuit ▶ Besides the main power circuits, also disconnect additional and auxiliary circuits ▶ Cover or insulate adjacent live parts ▶ The presence of a voltage-free state can only be clearly identified by a qualified electrician. ▶ When the work has been concluded, follow the procedure in reverse.

3.2 Other hazards

	<p>⚠ WARNING</p>
	<p>Contactors must only be used for the purposes specified in the specifications and data sheets. Incorrect use can cause accidents and severe personal injury.</p> <ul style="list-style-type: none"> ▶ The manufacturer will not be responsible for accidents arising from improper use of the product.

	<p>⚠ CAUTION</p>
	<p>During continuous operation the contactors may become hot. Risk of burns!</p> <ul style="list-style-type: none"> ▶ Before beginning any checks or maintenance on the contactors ensure that the heated components have cooled down.

	<p>⚠ CAUTION</p>
	<p>The contactors contain sharp-edged parts. Risk of injuries!</p> <ul style="list-style-type: none"> ▶ Use appropriate tools for installation and maintenance work on the contactors. ▶ Wear safety gloves when handling sharp-edged components.

3.3 Measures for avoiding damage and malfunctions

ATTENTION

Aggressive liquids may damage the contactors.

- ▶ Ensure the contactors do not come into contact with corrosive liquids.

ATTENTION

Improper handling of the contactors, e.g. dropping on the floor, can result in breaks, cracks and deformation.

- ▶ Ensure the contactors are always handled correctly.
- ▶ Do not throw the contactors on the floor.
- ▶ At regular intervals perform a visual check of the contactors for possible damage.
- ▶ Immediately replace any damaged parts.

ATTENTION

Depending on the product type, contactors can contain permanent magnets. Such magnets can attract ferromagnetic parts resulting in damage to the contactors.

- ▶ Ensure that the contactors are installed in a location where it is not possible for them to attract any ferromagnetic parts.

ATTENTION

Depending on the product type, contactors can contain permanent magnets. These permanent magnets can destroy the data on the magnetic strips of credit or similar cards.

- ▶ Keep credit or similar cards away from the contactors.

ATTENTION

During switching off, strong electromagnetic fields are generated in the vicinity of the contactors. These may influence other components close to the contactors.

- ▶ Make sure that the contactors are installed in a location where no other components are affected.

ATTENTION

In the case of damage, wear and/or soiling of the contactors - in the form of a partial break, sharp edges and discoloured surfaces - the functional reliability of the contactors is no longer ensured.

- ▶ Visually inspect the contactors regularly to detect wear and soiling.
- ▶ Replace damaged parts immediately.
- ▶ Immediately remove any soiling without leaving any residues.
- ▶ Immediately replace any parts with persistent soiling.

ATTENTION

Detent-edged rings and detent-edged washers have a limited life time. After screws secured with detent-edged rings or detent-edged washers have been undone three times, the rings or washers must be replaced by new ones.

- ▶ Record the frequency of undoing of the screws in the work log.
- ▶ Replace detent-edged rings or detent-edged washers with new ones after the screws have been undone three times.

4. Product information

4.1 C320 – 1 pole bi-directional DC NO contactors

The C320 is a single-pole bi-directional DC contactor in the power class up to 1,000 A. It ensures that high loads are switch-off safely and provides reliable protection in the event of a fault in the system. Typical applications are the use as main contactor in battery management systems of high-voltage vehicle batteries, in charging stations for e-mobility, in battery test benches but also in the DC circuits of inverters of photovoltaic systems. A very efficient ceramic arc chamber, double-break contacts and a high breaking capacity are important features of the new contactor.

- ▶ Compact dimensions – high rated insulation voltage U_i up to 1,800 volts
- ▶ High making capacity I_{cm} of up to 3,000 amps and an excellent breaking capacity
- ▶ High thermal continuous current I_{th} of up to 1,000 amps and high rated short-time withstand current I_{cw} up to 4,500 amps
- ▶ Full bidirectionality – safe disconnection of high power independent of the current flow direction
- ▶ 4 auxiliary switches, 2 of them with mirror contact function for diagnosis and switching status monitoring
- ▶ Low energy consumption and low heating thanks to sophisticated coil saving circuit

4.2 Technical information and material properties

For technical information and material properties, refer to the corresponding data sheets and to our **C320 catalogue**. The **C320 catalogue** is available under: https://www.schaltbau.com/media/C320_en.pdf

4.3 Overview

C320K/1000

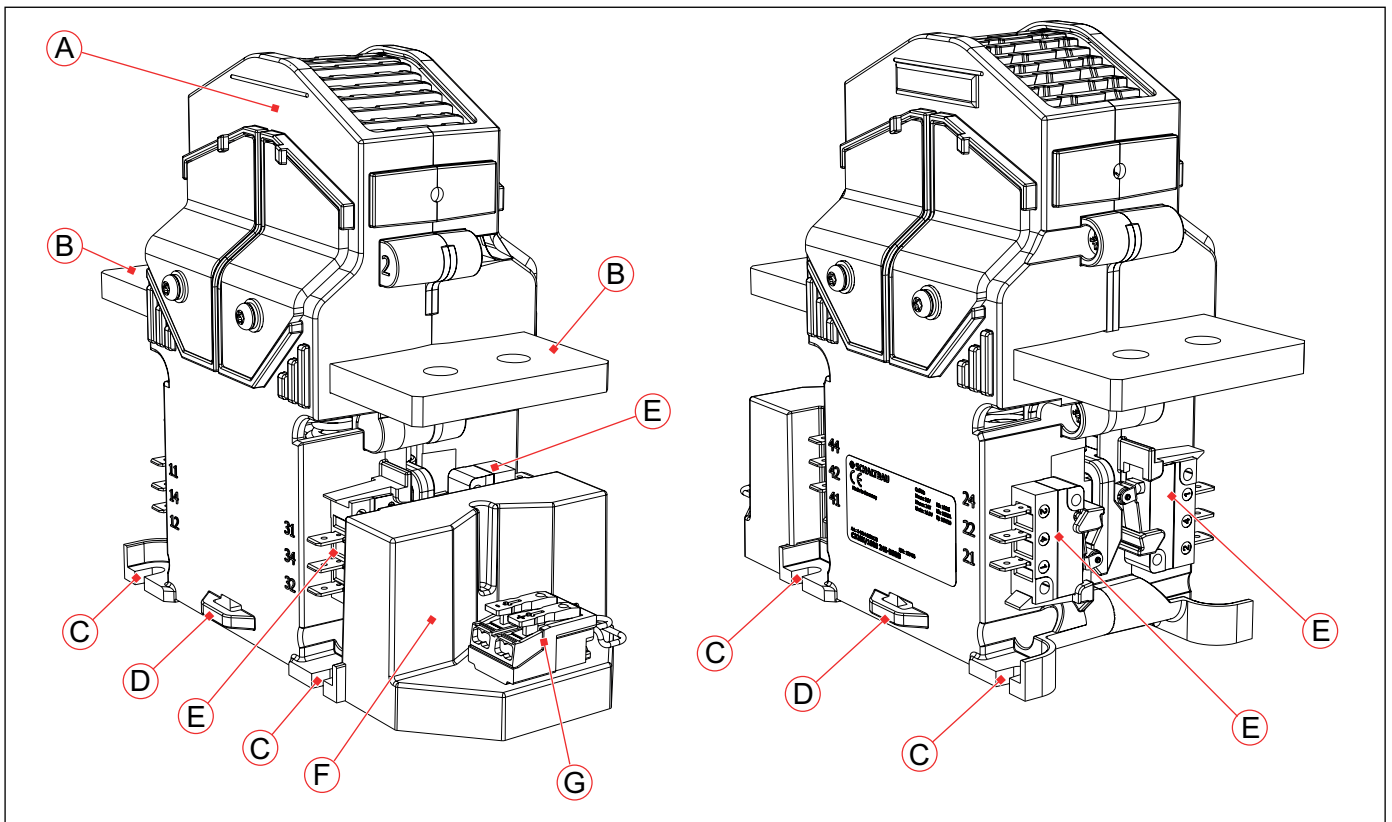

- A Arcing chamber
- B Main contacts: connection M8, torque 10 ... 12 Nm
- C Base plate with 4 fastening holes for M5 screws, torque 2.3 ... 2.7 Nm
- D Fixing lugs for bundling and fixing control wires with cable ties
- E Auxiliary switch S870 W1D1 t, flat plug connections 6.3 x 0.8 mm
(dependent on the design, up to 4 auxiliary switches per contactor are possible)
- F Economy circuit for coil
- G Coil terminal: cage clamp connection

C320S/1000

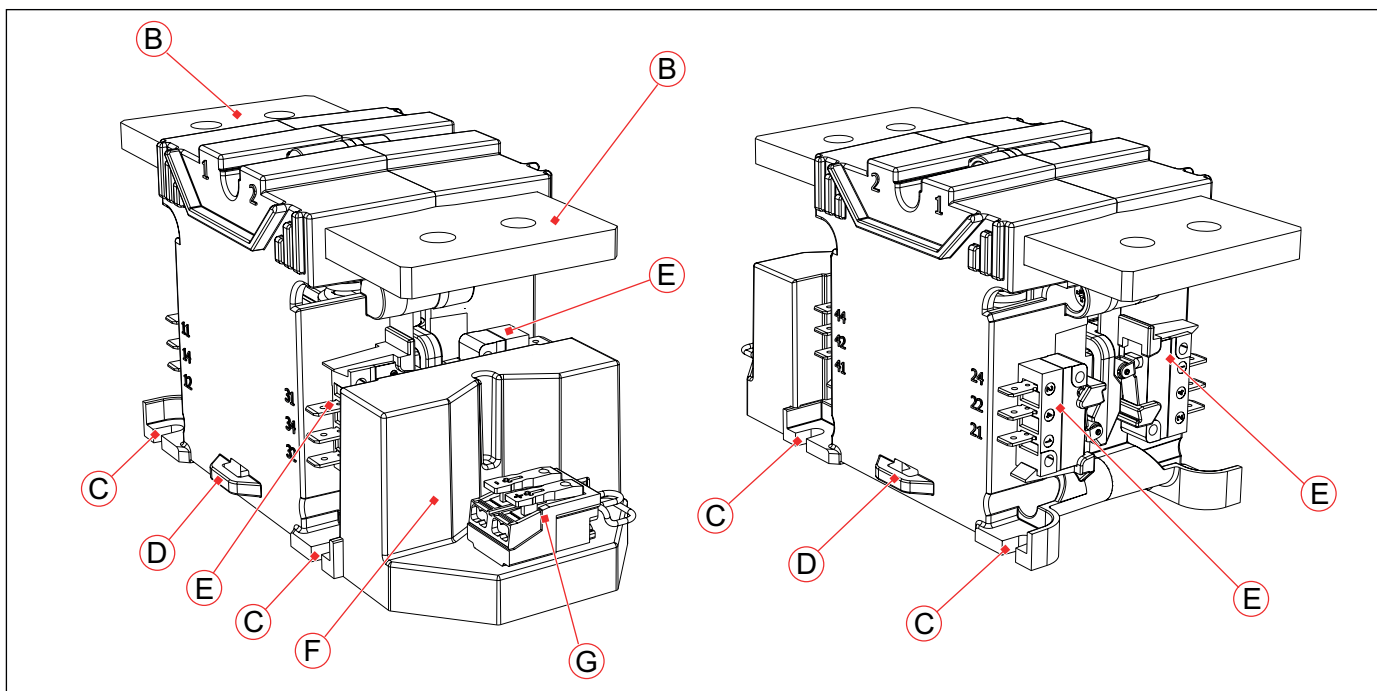

- B Main contacts: connection M8, torque 10 ... 12 Nm
- C Base plate with 4 fastening holes for M5 screws, torque 2.3 ... 2.7 Nm
- D Fixing lugs for bundling and fixing control wires with cable ties
- E Auxiliary switch S870 W1D1 t, flat plug connections 6.3 x 0.8 mm
(dependent on the design, up to 4 auxiliary switches per contactor are possible)
- F Economy circuit for coil
- G Coil terminal: cage clamp connection

5. Storage

ATTENTION

Moisture and dust can damage the contactors. If the device is to be stored for a prolonged period of time:

- ▶ Store the device in its original packaging,
- ▶ Store the device in a dry and dust-free location.

Return shipments

Schaltbau recommends retaining the original packaging for any return shipments.

If the original packaging is not available, care must be taken to pack the contactor in a way that prevents damage during shipment.

6. Unpacking

6.1 Unpacking the device

- ▶ Before opening the packaging, perform a visual inspection for any signs that could indicate damage having occurred during transport (impacts, bumps, dropping, etc.).
- ▶ If any signs indicate that the contactor has been subject to excessive impacts do not install it.

6.2 Check parts for transport damage

ATTENTION

If parts are damaged, functional reliability of the contactor has been lost.

- ▶ Before installing, check all parts for possible transport damage.
- ▶ Do not install damaged parts.

7. Installation

7.1 Mounting

Dimensions/interfaces and further technical specifications

The dimensions and other technical specifications are given in the respective data sheets or can be found in our *C320 catalogue*. The *C320 catalogue* is available under: https://www.schaltbau.com/media/C320_en.pdf

Preparatory measures

- ▶ A suitable mounting plate with 4 mounting holes in accordance with the following dimensional drawings (**Fig. 1 and Fig. 2**) must be provided for fastening of the contactors.
- ▶ The mounting holes can be either:
 - threaded holes (for threaded screws)
 - or through holes (for threaded screws and nuts)
- ▶ Fastening of the contactors on the mounting plate is performed using four M5 mounting screws.
 - The length of the mounting screws must be determined dependent on the structural circumstances.
 - To secure the mounting screws so that they do not come loose, appropriate screw locking elements must be provided. Schaltbau recommends using Schnorr washers (or similar).
 - The mounting screws must be equipped with washers (resting on the device). Installation without washers is not permitted!
 - The mounting screws must be tightened to a torque of 2.3 ... 2.7 Nm (screws of strength class 4.6).

Mounting holes

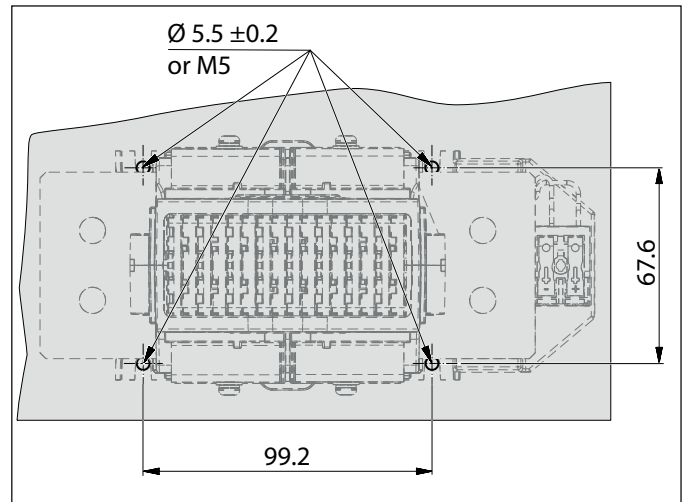

Fig. 1: C320K: Dimensions and layout of mounting holes

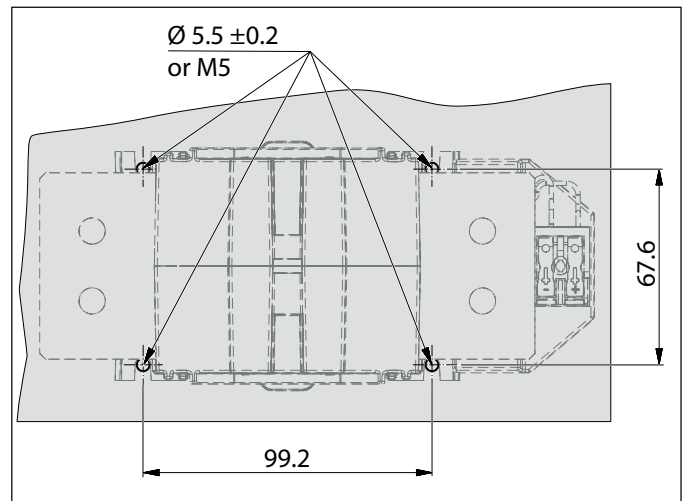

Fig. 2: C320S: Dimensions and layout of mounting holes

Mounting positions

The contactors are designed for horizontal or vertical mounting. Examples of correct mounting positions are presented in *Fig. 3/A* and *Fig. 4/A*. Incorrect mounting positions are shown in *Fig. 3/B* and *Fig. 4/B*. These mounting positions (B) are not permitted!

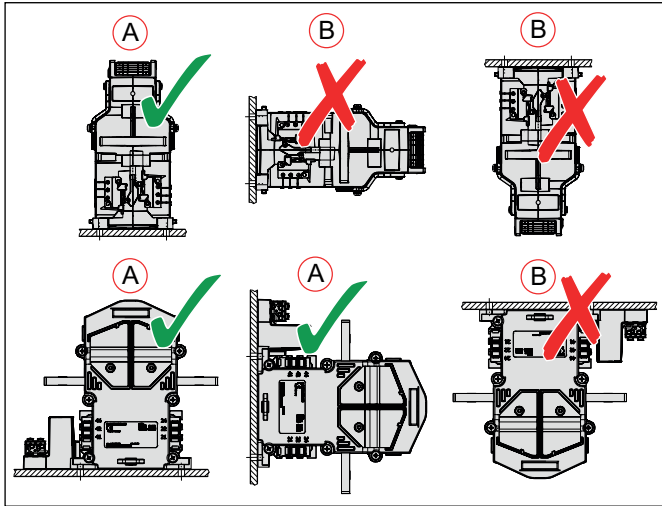

Fig. 3: C320K: Examples of correct mounting positions (A) and incorrect mounting positions (B).

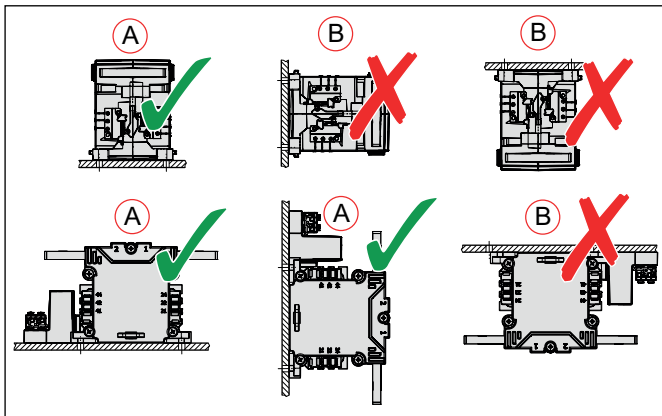

Fig. 4: C320S: Examples of correct mounting positions (A) and incorrect mounting positions (B).

Required minimum clearances

- ▶ Switching of high voltage currents produces electric arcs and it is possible that plasma will escape from the openings of the arcing chambers. Therefore, it is extremely important to maintain the minimum clearances to ground/earth and the bus bars to avoid flashovers.

Minimum clearances for type C320K contactors

A minimum clearance from magnetic or magnetised parts is required on all sides and above for type C320K contactors. See *C320 catalogue*.

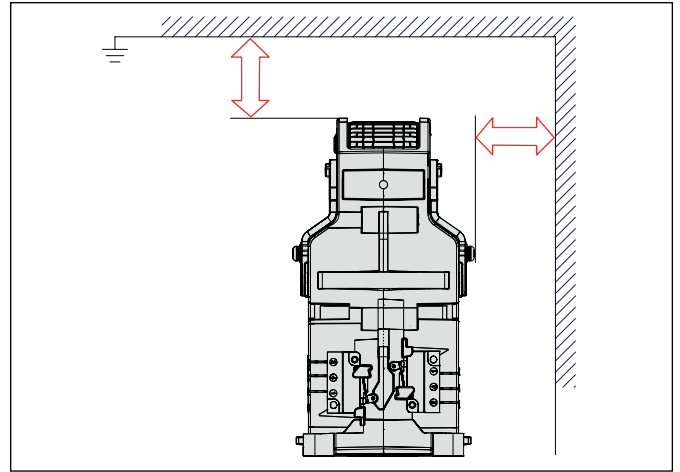

Fig. 5: C320K: Minimum clearance required from magnetic and earthed components. Clearances see *C320 catalogue*.

Minimum clearances for type C320S contactors

A minimum clearance from magnetic or magnetised parts is required on all sides and above for type C320S contactors. See *C320 catalogue*.

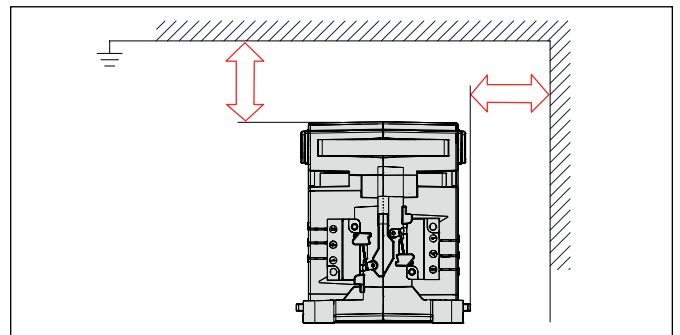

Fig. 6: C320S: Minimum clearance required from magnetic and earthed components. Clearances see *C320 catalogue*.

Ventilation requirements

- ▶ Ensure sufficient ventilation in the installation area, especially when disconnecting heavy loads. This allows the plasma to be dissipated more quickly to reduce the risk of flash-overs and corrosion.

Safety

- ▶ Installation must be performed by qualified trained personnel.

ATTENTION

When installing, ensure that no dirt can get into the contactor as a result of surrounding building activities.

ATTENTION

Detent-edged rings and detent-edged washers have a limited life time. After screws secured with detent-edged rings or detent-edged washers have been undone three times, the rings or washers must be replaced by new ones.

- ▶ Record the frequency of undoing of the screws in the work log.
- ▶ Replace detent-edged rings or detent-edged washers with new ones after the screws have been undone three times.

Tools required

- ▶ Socket spanner set, hexagon nuts
- ▶ Open-ended spanner set
- ▶ Torque wrench
- ▶ Hex key set

Installing the contactor

- ▶ Ensure that the contact surfaces on the mounting plate (3) are free from dirt and other contamination (e.g. metal chips).
- ▶ Position the contactor (1) on the mounting plate (3) which is provided with mounting holes.

ATTENTION

- ▶ The mounting screws M5 (2) must be equipped with washers (resting on the device). Installation without washers is not permitted!

- ▶ Secure the contactor to the mounting flange with 4 mounting screws M5 (2) on the mounting plate (3).
 - In designs with the mounting holes implemented as threaded holes, screw the mounting screws into the holes directly, not forgetting the washers.
 - In designs with through holes, fit the mounting screws and washers and tighten the screws using suitable screw locking elements and nuts.
- ▶ Tighten the mounting screws (2) to a torque of 2.3 ... 2.7 Nm (screws of strength class 4.6).

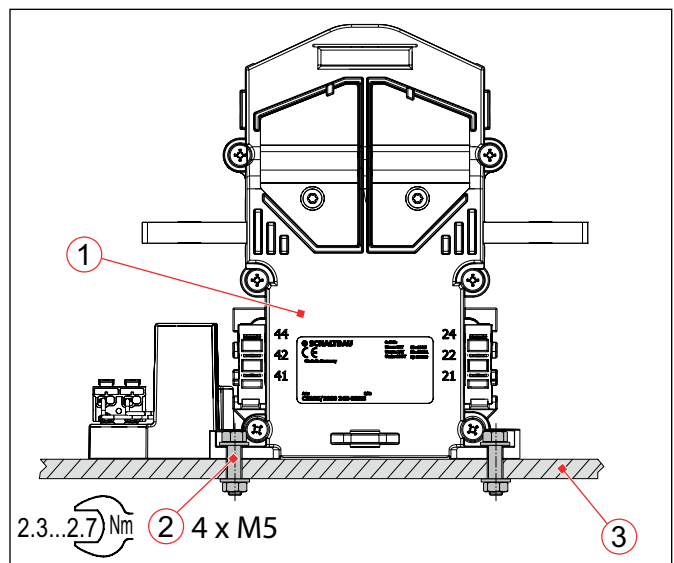

Fig. 7: C320K: Installing the contactor on the mounting plate

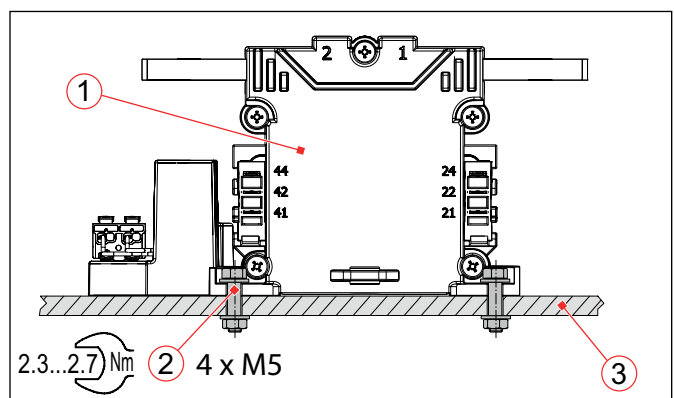

Fig. 8: C320S: Installing the contactor on the mounting plate

7.2 Electrical connection

Electrical data and other technical specifications

For the power consumption of the magnetic drive system and electrical data of the auxiliary switches as well as other technical specifications, refer to the respective data sheets and to our *C320 catalogue*. The *C320 catalogue* is available under:

https://www.schaltbau.com/media/C320_en.pdf

Preparatory measures

- ▶ Connection of the main power circuit can be implemented with wires or busbars.
- ▶ The minimum conductor cross-sections for the main terminal connection must be observed.
- ▶ If connecting wires are used, they must be selected taking into consideration the insulation class and the ambient conditions.
- ▶ The minimum conductor cross-sections for the connecting wires are given in our *C320 catalogue* and must be adhered to.
The *C320 catalogue* is available under:
https://www.schaltbau.com/media/C320_en.pdf
- ▶ The connecting wires of the main power circuit must be fitted with appropriate ring terminals (for M8 terminal screws).
- ▶ Schaltbau recommends Schnorr washers (or similar) to prevent the terminal screws from coming loose.
- ▶ The main terminal screws must be tightened to a torque of 10 ... 12 Nm.
- ▶ The connections for the auxiliary switches are made with flat plugs. Consequently, the control wires must be equipped with corresponding flat receptacles 6.3 x 0.8 mm.
- ▶ The maximum permissible conductor cross-section of the auxiliary switch control wires is 1.5 mm²/ AWG 16 stranded wire.

- ▶ A cage clamp terminal block is provided for the coil control wires. The control wires for the coil connection must be stripped accordingly (if necessary, fit with appropriate wire end sleeves):
 - conductor cross-section
0.5 ... 1.5 mm² with sleeve
0.5 ... 2.5 mm² without sleeve
 - stripping length: 8 ... 9 mm
- ▶ For the power consumption of the coil drive system and the electrical data of the auxiliary switches refer to our catalogues:
 - C320 (Catalogue C320 series devices)
 - D70 (Catalogue auxiliary switches S870)

Safety

DANGER



The contactors are used for high voltage switching. Contact with live electrical parts can result in serious injuries or even death!

Live parts are all metal parts belonging directly to one of the circuits or wires connecting to them. All other visible metal parts and wiring may also be live if a fault exists.

Before starting any work on the contactors, always comply with the following safety rules:

- ▶ Disconnect on all sides
- ▶ Secure to prevent switching back on
- ▶ Clearly identify the working area
- ▶ Check that a voltage-free state exists
- ▶ Earth and short circuit; this includes discharging any capacitors in the main circuit
- ▶ Besides the main power circuits, also disconnect additional and auxiliary circuits
- ▶ Cover or insulate adjacent live parts
- ▶ The presence of a voltage-free state can only be clearly identified by a qualified electrician.
- ▶ When the work has been concluded, follow the procedure in reverse.

ATTENTION

Detent-edged rings and detent-edged washers have a limited life time. After screws secured with detent-edged rings or detent-edged washers have been undone three times, the rings or washers must be replaced by new ones.

- ▶ Record the frequency of undoing of the screws in the work log.
- ▶ Replace detent-edged rings or detent-edged washers with new ones after the screws have been undone three times.

Tools required

- ▶ Socket spanner set, hexagon nuts
- ▶ Open-ended spanner set
- ▶ Torque wrench
- ▶ Continuity tester
- ▶ Cable ties

Connecting the S870 auxiliary switches

The control wires for the auxiliary switches must be fitted with flat receptacles (6.3 x 0.8 mm).

ATTENTION

- ▶ The maximum permissible conductor cross-section of the auxiliary contact control wires is 1.5 mm² / AWG 16 stranded wire.
- ▶ Bending of the connections on the auxiliary switches is not permitted!
- ▶ Mechanically secure the control wires to minimise feedback effects of forces caused by the wires (e. g. shock, vibrations) acting on the terminals.

- ▶ Route the coil control wires (1) to the auxiliary switches (2).
- ▶ Plug the pre-assembled control wires with the receptacles (1) to the connections (2) of the auxiliary switches.
- ▶ Check that the control wires of the auxiliary switches are correctly installed.
- ▶ Check the routing of the wiring. Wires must not be squeezed or bent.
- ▶ If applicable bundle and secure the wires using cable ties. For this purpose, there are fixing lugs at the bottom on both sides of the contactor.

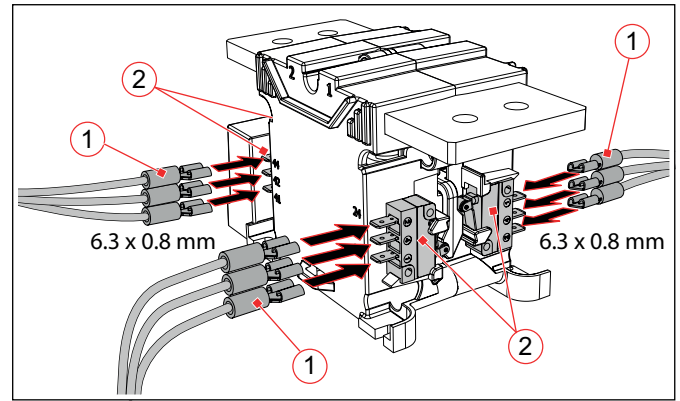

Fig. 10: C320S: Connecting the S870 auxiliary switches

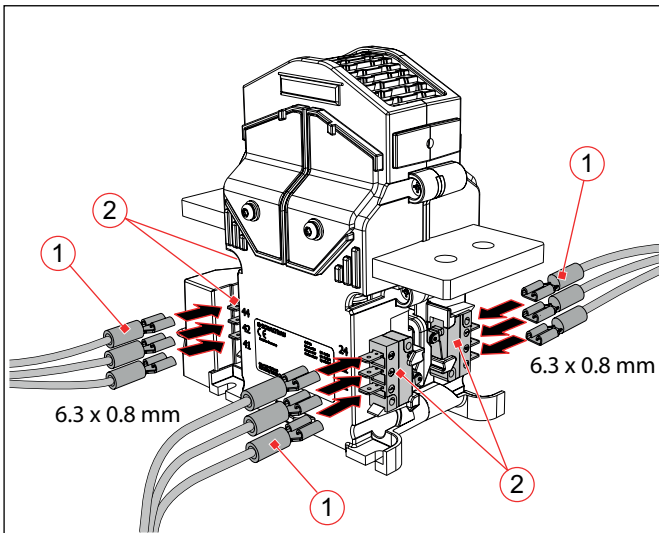

Fig. 9: C320K: Connecting the S870 auxiliary switches

Connecting the coil

A cage clamp terminal block is provided for the coil control wires. The control wires for the coil connection must be stripped accordingly (if necessary, fit with appropriate wire end sleeves):

- conductor cross-section
0.5 ... 1.5 mm² with sleeve
0.5 ... 2.5 mm² without sleeve
- stripping length: 8 ... 9 mm

ATTENTION

The value of the overvoltage limitation is part of the magnetic system and must not be modified and in particular not be short-circuited (e.g. by an external diode).

- ▶ Make sure that no such diode is used in your control circuit.

ATTENTION

- ▶ Mechanically secure the control wires to minimise feedback effects of forces caused by the wires (e. g. shock, vibrations) acting on the terminals.

- ▶ Route the coil control wires (1) to the cage clamp terminal block (2).
- ▶ Connect the control wires (1). Make sure that the polarity (+/-) is correct.
 - Wrong polarity will not damage the contactor.
 - Due to wrong polarity the contactor will not work properly.
- ▶ Check that the coil control wires are correctly installed.
- ▶ Check the routing of the wiring. Wires must not be squeezed or bent.
- ▶ If applicable bundle and secure the wires using cable ties. For this purpose, there are fixing lugs at the bottom on both sides of the contactor.

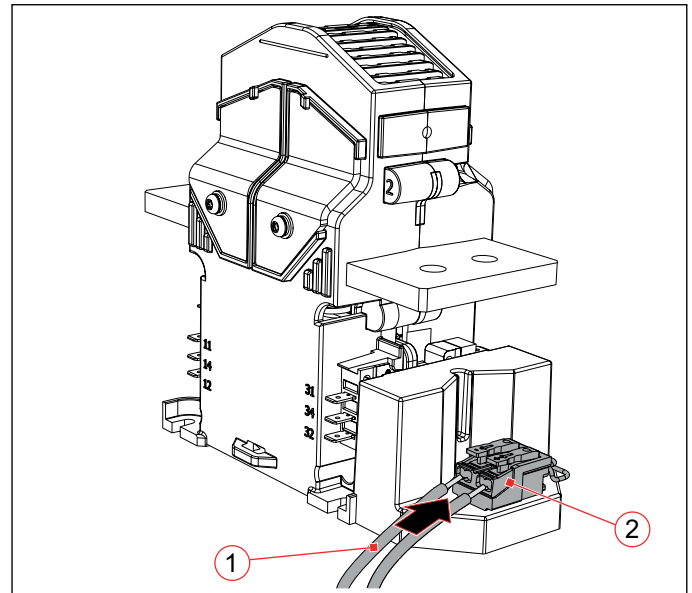

Fig. 11: C320K: Connecting the coil

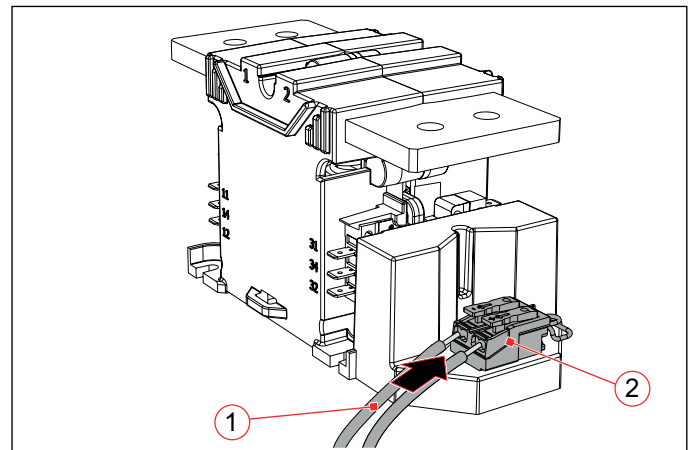

Fig. 12: C320S: Connecting the coil

Connecting the main contacts

ATTENTION

Ensure that the connection points for the main contacts are free from corrosion.

Connection example using wires

The connecting wires of the main power circuit must be fitted with appropriate ring terminals (for M8 terminal screws).

Examples for the connection with wires are shown in **Fig. 13** and **Fig. 14**.

- ▶ Route the pre-assembled connecting wires to both main contacts (4).
- ▶ Screw the 4 ring terminals (3) in place from above using the terminal screws (1), nuts (5) and suitable screw locking elements (2).
 - Schaltbau recommends using Schnorr washers (or similar).
- ▶ Tighten the terminal screws (1) to a torque of 10 ... 12 Nm.

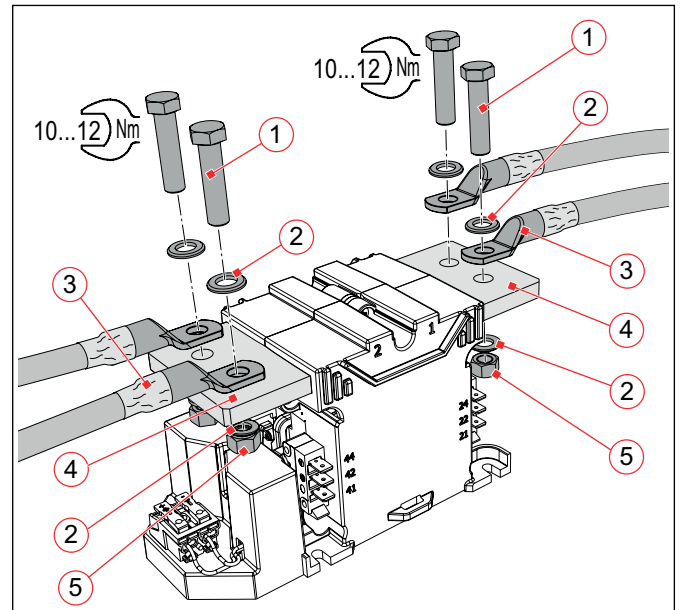

Fig. 14: C 320S: Connecting the main contacts (connection example using wires)

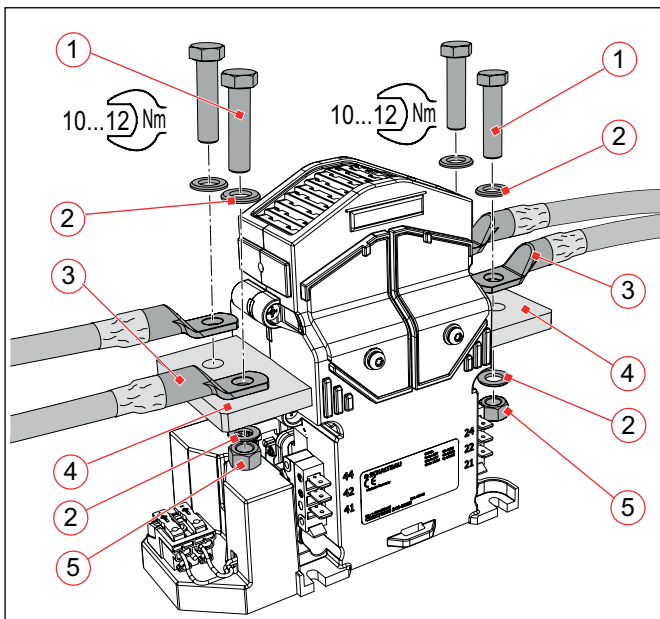

Fig. 13: C 320K: Connecting the main contacts (connection example using wires)

Connection example using busbars

As an alternative to connection using wires, the main power circuit can be connected with busbars.

Examples for the connection with busbars are shown in **Fig. 15** and **Fig. 16**.

- ▶ Route the busbars (3) to both main contacts (4).
- ▶ Screw the busbars (3) to the main contacts (4) using the terminal screws (1), nuts (5) and suitable screw locking elements (2).
 - Schaltbau recommends using Schnorr washers (or similar).
- ▶ Tighten the terminal screws (1) to a torque of 10 ... 12 Nm.

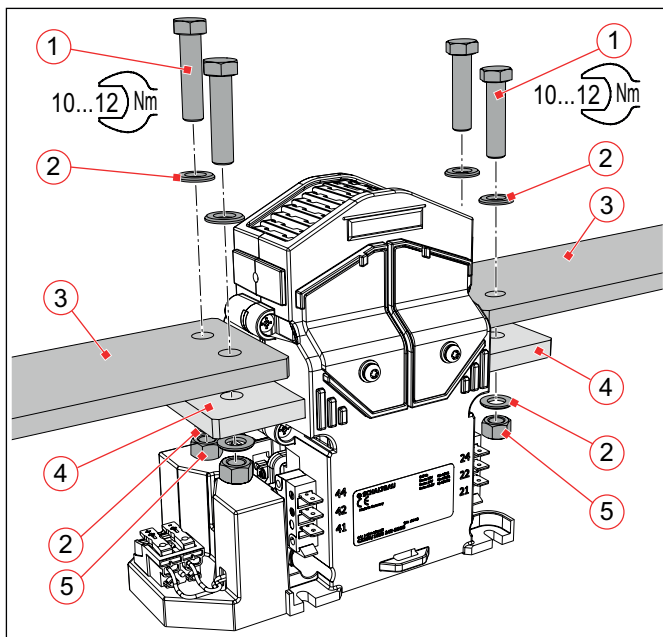

Fig. 15: C 320K: Connecting the main contacts (connection example using busbars)

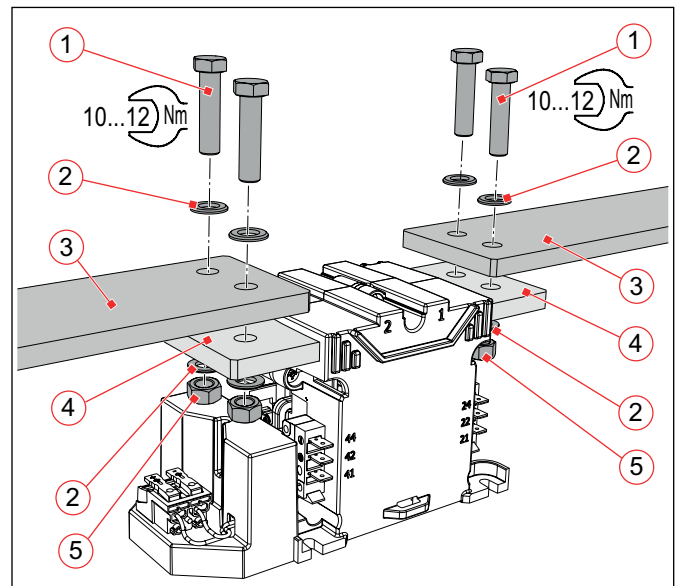

Fig. 16: C 320S: Connecting the main contacts (connection example using busbars)

7.3 Checks

After the installation, perform the following checks:

- ▶ Check that the contactors are correctly installed on the mounting plate and tightly screwed in place.
- ▶ Check that the connecting wires or busbars are correctly installed and fit tightly at the main contacts.
- ▶ Check that the control wires of the coil terminals are correctly installed and have the correct polarity.
- ▶ Check that the control wires are correctly connected to the auxiliary switches.
Check the correct assignment and function of the auxiliary switches using a continuity tester.
- ▶ Switch the contactor several times without activating the main power circuit.
- ▶ Check the pull-in and drop-off voltage based on the Schaltbau specifications. See **C320 catalogue**.
- ▶ Check the routing of the wiring. Wires must not be squeezed or bent. If applicable bundle and secure wires using cable ties.
- ▶ After every installation or after maintenance, check the contactor for correct operation in accordance with the following standards:
 - EN/IEC 60077-2
 - EN/IEC 60947-4-1

8. Maintenance

Note the expert knowledge which is essential for carrying out maintenance work, referred to in chapter "2. General and safety information".

8.1 Safety

	⚠ DANGER
	<p>The contactors are used for high voltage switching. Contact with live electrical parts can result in serious injuries or even death!</p> <p>Live parts are all metal parts belonging directly to one of the circuits or wires connecting to them. All other visible metal parts and wiring may also be live if a fault exists.</p> <p>Before starting any work on the contactors, always comply with the following safety rules:</p> <ul style="list-style-type: none"> ▶ Disconnect on all sides ▶ Secure to prevent switching back on ▶ Clearly identify the working area ▶ Check that a voltage-free state exists ▶ Earth and short circuit; this includes discharging any capacitors in the main circuit ▶ Besides the main power circuits, also disconnect additional and auxiliary circuits ▶ Cover or insulate adjacent live parts ▶ The presence of a voltage-free state can only be clearly identified by a qualified electrician. ▶ When the work has been concluded, follow the procedure in reverse.

8.2 Preventive maintenance

Contactors of the C320 series are maintenance-free within the rated mechanical life time. The electrical life time depends on the number of switching cycles under heavy load conditions and may vary for different applications. In normal use, this corresponds to a decade-long operating period.

Intervals for regular tests/checks

To ensure the correct function and a prolonged operational life span of the contactors, the following checks and maintenance must be regularly performed.

Test/check	Interval
External visual inspection of the contactor	▶ 1x per year
Check of the main contacts (both, stationary and moving contacts)	▶ 1x to 2x per year
Checking of the auxiliary switches	▶ Every 2 years

If the contactors are operated in a particularly dirty environment, the visual checks should be performed at shorter intervals. Dirt can impair the clearance and creepage distances, which can result in a shorter service life or to a malfunction.

Extraordinary checks need only be carried out if there has been a significant and extraordinarily high recorded number of switching cycles under short-circuit conditions.

	⚠ DANGER
	<p>If damage to the contactor, wires or bus-bars is visible, the safety of the contactor is no longer guaranteed.</p> <ul style="list-style-type: none"> ▶ Immediately submit any damaged contactors or components for maintenance.

ATTENTION

Detent-edged rings and detent-edged washers have a limited life time. After screws secured with detent-edged rings or detent-edged washers have been undone three times, the rings or washers must be replaced by new ones.

- ▶ Record the frequency of undoing of the screws in the work log.
- ▶ Replace detent-edged rings or detent-edged washers with new ones after the screws have been undone three times.

Regular tests/checks

All of the maintenance activities that may be carried out on the contactors by skilled personnel are listed below.

Component	Tests/checks	Measures
Wires/busbars	Check for: <ul style="list-style-type: none"> ▶ damaged wires, cable lugs ▶ damaged insulation ▶ damaged busbars ▶ kinked or crushed wires ▶ loose or missing fastening elements ▶ correct tightening torque of the terminal screws 	In case of faults: <ul style="list-style-type: none"> ▶ immediately replace damaged wires or cable lugs ▶ immediately replace damaged busbars ▶ tighten loose fastening elements immediately, replace missing fastening elements ▶ tighten the terminal screws to the rated torque
Contactors housing	Check for: <ul style="list-style-type: none"> ▶ dirt ▶ loose or missing fastening elements ▶ penetrations, holes in the housing wall ▶ damage or wear ▶ broken ceramic arcing plates (only for C320K) 	In case of faults: <ul style="list-style-type: none"> ▶ remove any dirt that may be present ▶ tighten loose fastening elements immediately ▶ replace missing fastening elements ▶ tighten a loose contactor immediately ▶ if the contactor housing is damaged or heavily worn replace the entire contactor ▶ if there are broken ceramic plates in the arcing chamber replace the entire contactor
Main contacts (both stationary contacts and moving contact bridge)	Check for: <ul style="list-style-type: none"> ▶ damage or wear ▶ traces of combustion residue (slight soot deposits permitted) <p>A certain level of experience is required to assess the state of the contacts. Even after a few load switching cycles, to a lay user the contacts appear worn and the surroundings fouled. Replacement of the contactor is only necessary after more than 50% of the contact material is burnt through.</p>	In case of faults: <ul style="list-style-type: none"> ▶ if more than 50% of the contact material is burnt through, replace the entire contactor, see section "8.2 Preventive maintenance" / "Checking the main contacts".

Component	Tests/checks	Measures
Auxiliary switches S870	<p>Check for:</p> <ul style="list-style-type: none"> ▶ dirt ▶ damage or wear on the housing ▶ signs of short circuits <p>The auxiliary switches can be accessed from the outside for a simple visual inspection. Under normal operating conditions (there have been no short circuits in the control circuit) there is no general need to replace the auxiliary switches. However, in the event of a short circuit in the control circuit, it is possible that the auxiliary switches may be damaged and need to be replaced.</p>	<p>In case of faults:</p> <ul style="list-style-type: none"> ▶ replace the auxiliary switches, see section "8.3 Corrective maintenance" / "Replacing the S870 auxiliary switches"

Checking the main contacts

The housing of the contactor has inspection openings on both narrow sides (1) through which the main contacts can be inspected.

Safety



⚠ DANGER

Before starting work on the contactors, make sure that

- ▶ no voltage is present,
- ▶ all safety regulations are fully observed.
- ▶ Be sure to observe chapter **"3. Hazards and safety precautions"** on page 6.

Tools required

- Torch
- Inspection mirror

Procedure

- ▶ Check the main contacts through the inspection openings (1). In doing so check both
 - the stationary contacts (2),
 - as well as the contacts (3) on the moving contact bridge.
- ▶ To get a better view of the contacts use a torch and an inspection mirror.
- ▶ If more than 50% of the contact material is burnt through, replace the contactor as a whole unit.

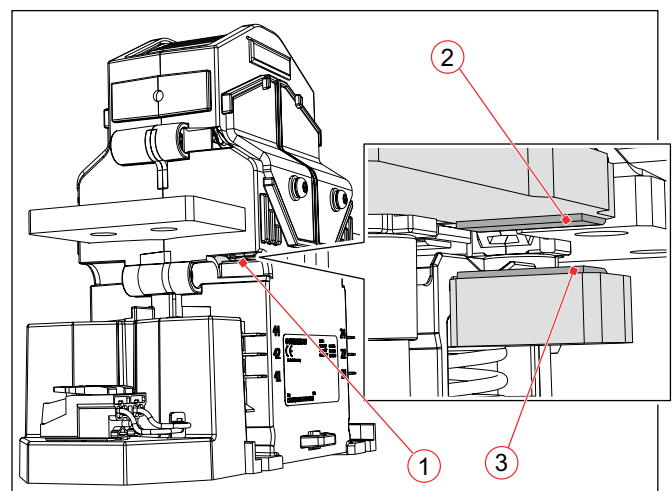

Fig. 17: C320K: Checking the main contacts

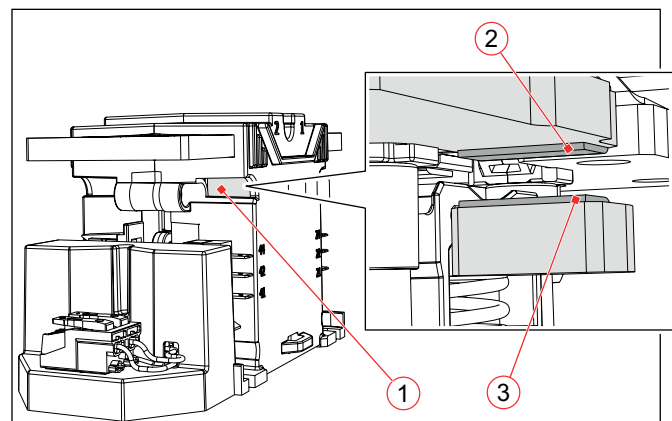

Fig. 18: C320S: Checking the main contacts

8.3 Corrective maintenance

The contactors are largely maintenance-free. Therefore there is no general requirement to replace parts during its service life. Excepted from this are auxiliary switches.

Replacing the S870 auxiliary switches

Under normal operating conditions (there were no short circuits in the control circuit), there is no general need to replace the auxiliary switches.

However, in the event of a short circuit in the control circuit, it is possible that the auxiliary switches may be damaged and need to be replaced.

If auxiliary switches have to be replaced, always replace all auxiliary switches of the contactor.

Only use identical types of auxiliary switches specified for the contactor.

Safety

	<p>⚠ DANGER</p>
	<p>Before starting work on the contactors, make sure that</p> <ul style="list-style-type: none"> ▶ no voltage is present, ▶ all safety regulations are fully observed. ▶ Be sure to observe chapter "3. Hazards and safety precautions" on page 6.

Tools required

- Continuity tester

Procedure

- ▶ Pull off the receptacles of the control wires from the auxiliary switches.
- ▶ Carefully release the snap-fit hook (1) of the catch mechanism.
 - Be careful not to damage the snap-fit hook!
- ▶ Continue to hold the snap-fit hook (1) carefully and turn the auxiliary switch (2) approx. 45° clockwise around the bearing pin (3).
- ▶ Pull the auxiliary switch (2) off the bearing pin (3).
- ▶ Place a new auxiliary switch (2) in approx. 45° position (as shown in Fig. 19 to Fig. 22) on the bearing pin (3).
- ▶ Carefully turn the auxiliary switch (2) counterclockwise around the bearing pin (3) until it slides into the mounting and the snap-fit hook (1) engages.
- ▶ Replace all other auxiliary switches in the same way.

- ▶ Plug the receptacles of the control wires back on to the contacts of the auxiliary switches.
- ▶ Check the correct connection of the control wires to the auxiliary switches.
- ▶ Use a continuity tester to check the correct assignment and correct function of the auxiliary switches.
- ▶ Finally, subject the contactor to a complete check as described in section "7.3 Checks" on page 21.

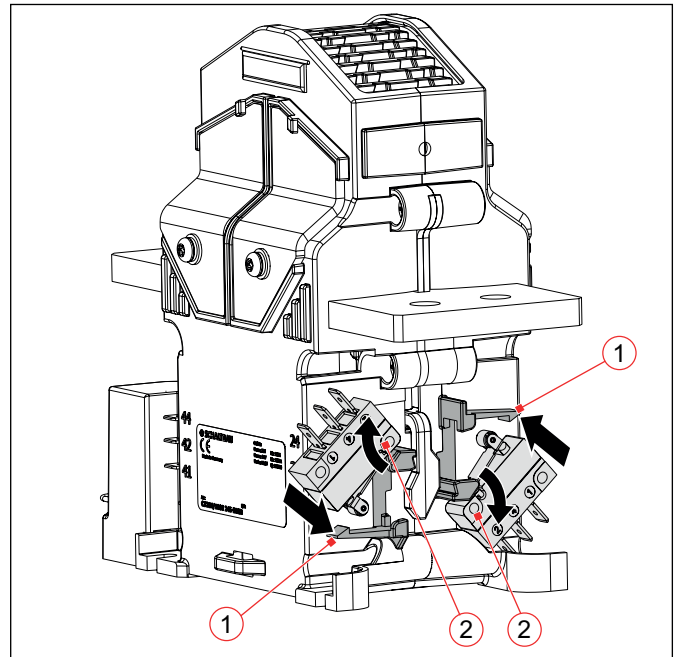

Fig. 19: C320K: Replacing the auxiliary switches - 1

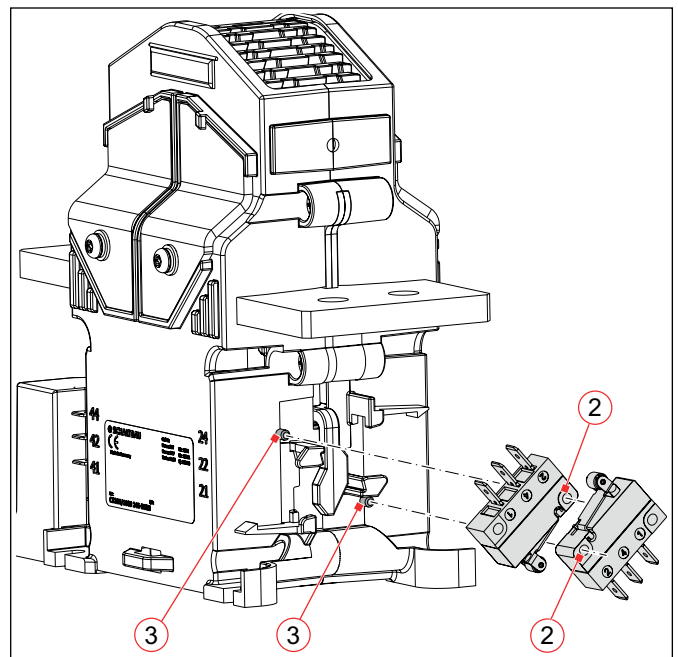

Fig. 20: C320K: Replacing the auxiliary switches - 2

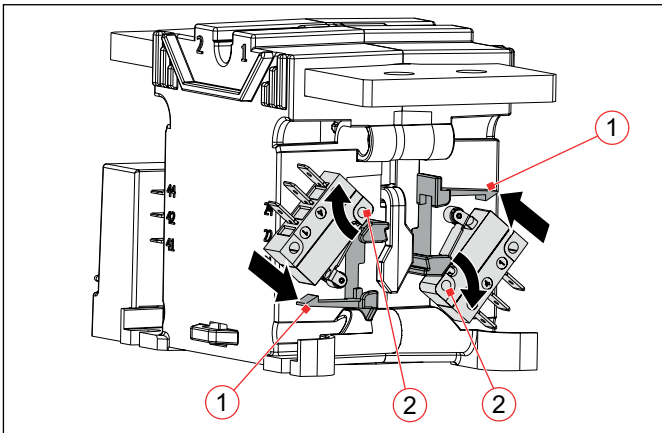

Fig. 21: C320S: Replacing the auxiliary switches - 1

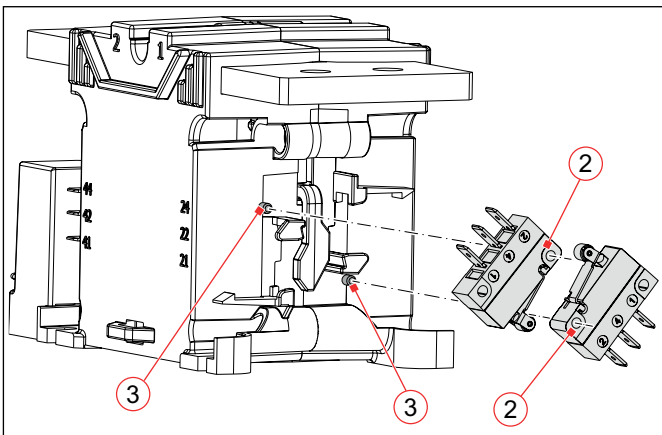



Fig. 22: C320S: Replacing the auxiliary switches - 2

9. Spare parts

	<p>Important! When ordering spare parts, always specify the precise type and article number of the contactor. You can find this data on the rating plate.</p>
---	---

Designation
Auxiliary switch S870 W1D1 t *

* If auxiliary switches have to be replaced, always replace all auxiliary switches of the contactor.

Only use identical types of auxiliary switches specified for the contactor.

10. Technical data

Technical data and information on the material properties for the contactors of the C320 series are given in our *C320 catalogue*.

Schaltbau products are subject to continual improvement. Therefore, the product information in catalogues, data sheets, etc. may change at any time. Therefore, only the latest version of a catalogue is valid at any time – downloads available under:

https://www.schaltbau.com/media/C320_en.pdf

11. Disposal

This product is designed for exclusive professional use by commercial companies. The owner is responsible for ensuring an environmentally sound disposal of this product at the end of its working life.

This product or parts of it may not be disposed of with other household waste.

To prevent possible harm to the environment or human health from uncontrolled waste disposal, please separate this product or parts of it from other types of wastes and recycle it responsibly to promote the sustainable reuse of material resources.

Please observe all local regulations and recommendations for the disposal, recycling or environmentally friendly processing of the parts and materials that have been used or replaced during installation, operation, and maintenance tasks.

At the end of the product's useful life ensure environmentally sound disposal of the product according to the legal regulations and requirements for electrical and electronic waste equipment in your country.

Schaltbau GmbH

For detailed information on our products and services visit our website – or give us a call!

Schaltbau GmbH
Hollerithstrasse 5
81829 Munich
Germany



Phone +49 89 9 30 05-0
Fax +49 89 9 30 05-350
Internet www.schaltbau.com
e-Mail contact@schaltbau.de

with compliments:



The production facilities of Schaltbau GmbH have been IRIS certified since 2008.



Certified to DIN EN ISO 14001 since 2002. For the most recent certificate visit our website.



Certified to DIN EN ISO 9001 since 1994. For the most recent certificate visit our website.

Electrical Components and Systems for Railway Engineering and Industrial Applications

Connectors

- Connectors manufactured to industry standards
- Connectors to suit the special requirements of communications engineering (MIL connectors)
- Charging connectors for battery-powered machines and systems
- Connectors for railway engineering, including UIC connectors
- Special connectors to suit customer requirements

Snap-action switches

- Snap-action switches with positive opening operation
- Snap-action switches with self-cleaning contacts
- Snap-action switch made of robust polyetherimide (PEI)
- Snap-action switch with two galvanically isolated contact bridges
- Special switches to suit customer requirements

Contactors Emergency disconnect switches

- Single and multi-pole DC contactors
- High-voltage AC/DC contactors
- Contactors for battery powered vehicles and power supplies
- Contactors for railway applications
- Terminal bolts and fuse holders
- DC emergency disconnect switches
- Special contactors to suit customer requirements

Electrics for rolling stock

- Equipment for driver's cab
- Equipment for passenger use
- High-voltage switchgear
- High-voltage heaters
- High-voltage roof equipment
- Equipment for electric brakes
- Design and engineering of train electrics to customer requirements