

3

Contactors

CL1115/02,
CL1215/02,
CL1315/02,

1, 2 and 3 pole
AC and DC NO contactors
for voltages up to 1,500 V

Catalogue C25.en

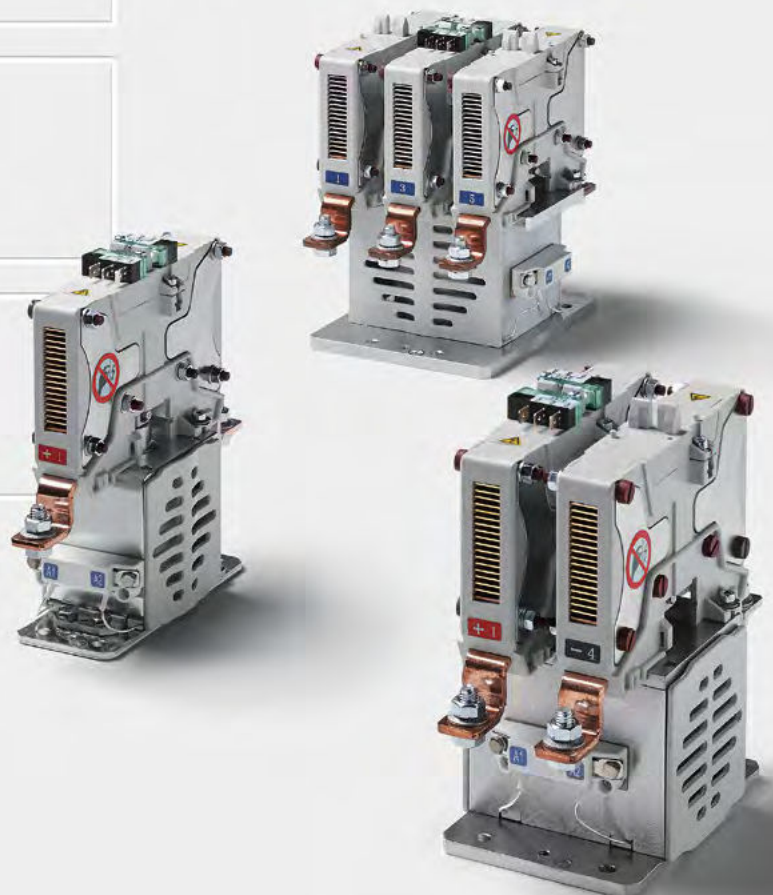

more information here:
schaltbau-gmbh.com

CL1115/02, CL1215/02, CL1315/02 1, 2 and 3 pole AC and DC NO contactors for voltages up to 1,500 V

The economical solution for switching medium power AC and DC loads

CL Series contactors are available as 1, 2 and 3 pole AC and DC versions. They guarantee reliable, low-wear switching of rated voltages up to 1,500 V and amperages up to 250 A. The compact contactors come with an arc chute that has proven itself many times over and are suitable for universal use in the harsh environmental conditions of industrial applications as well as in AC and DC railway networks.

Especially robust and environmentally friendly materials - from plastics featuring low smoke and low content of toxic gases up to cadmium-free contact tips - are used for the CL Series.

The contactors have been tested and approved by independent laboratories.

Features

- Compact, rugged design
- Long life
- Maintenance free in normal operation
- Rated voltage 1,500 V, current rating 250 A max.
- Double-break, cadmium free main contacts
- 1, 2 and 3 pole AC and DC versions available
- Drive system with coil tolerance according to railway standard
- Functional insulation for main circuit
- Basic insulation between main circuit and protective earth

Applications

- **Precharge contactor:** CL Series contactors are the ideal complement to our CT range. Used as precharge contactors the switchgear is best suited for switching medium power AC and DC loads.
- **Line contactor:** CL Series contactors are particularly suited as main switches of electric heating systems or starter and compressor motors and for switching field circuits of motors.

Ordering code

Series CL

Example:

CL1115/02 P 110ET-U2

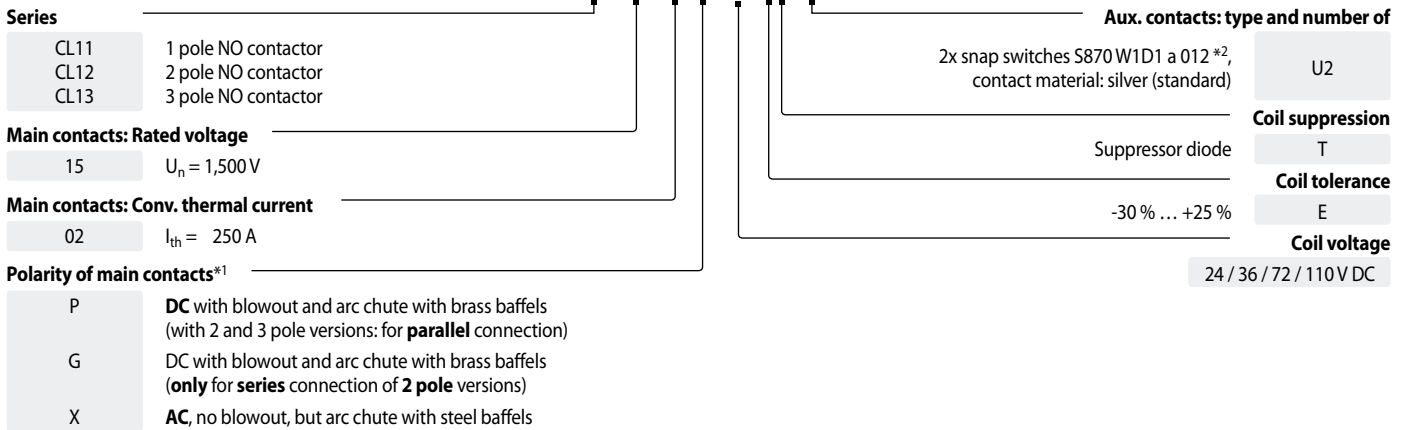

Note:
Presented in this catalogue are only stock items which can be supplied in short delivery time.
For some variants minimum quantities apply.
Please do not hesitate to ask for the conditions.

Special variant:

If you need a special variant of the contactor, please do not hesitate to contact us. Maybe the type of contactor you are looking for is among our many **special designs**. If not, we can also supply **customized designs**. In this case, however, minimum order quantities apply.

*1 DC contactors are fitted with permanent magnetic blowouts.

Select »P« with 2 and 3 pole versions for **parallel** connection
Select »G« **only** for **series** connection of **2 pole** versions
Observe polarity marking „+“ on the arc chute of the contactor!

*2 For S870 Series snap-action switches, refer to catalogue D70.

Specifications

Series CL

| Series | CL1115/02 | CL1215/02 | CL1315/02 |
|--|---|--|-------------------------|
| Type of voltage | DC, AC | | |
| Main contacts, number of, configuration | 1x SPST-NO | 2x SPST-NO | 3x SPST-NO |
| Nominal voltage U_n | 1,500 V | 1,500 V | 1,500 V |
| Rated operating voltage U_e | 1,800 V | 1,800 V | 1,800 V |
| Rated insulation voltage U_{Nm} | 2,200 V | 2,200 V | 2,200 V |
| Rated impulse withstand voltage U_{Ni} | 12 kV | 12 kV | 12 kV |
| Pollution degree / Overvoltage category | PD3 / OV3 | PD3 / OV3 | PD3 / OV3 |
| Switching surge overvoltage $U_e = 1,800$ V | < 6.6 kV | < 6.6 kV | < 6.6 kV |
| Conventional thermal current I_{th} at $T_a = 40^\circ$ C / at $T_a = 70^\circ$ C | 250 A / 200 A | 250 A / 200 A | 250 A / 200 A |
| Component category (IEC 60077-2) | A2 | A2 | A2 |
| Short-circuit making capacity I_{cm} | 1,5 kA | 1,5 kA | 1 kA |
| Breaking capacity I_{cn} ($T_2 < 15$ ms) DC, $U_e = 720$ V DC, $U_e = 1,200$ V DC, $U_e = 1,800$ V | 20 A 15 A 10 A | 20 A 15 A 10 A | 20 A 15 A 10 A |
| Breaking capacity I_{cn} ($T_2 < 1$ ms) DC, $U_e = 720$ V DC, $U_e = 1,200$ V DC, $U_e = 1,800$ V | 400 A 90 A 50 A | 400 A 90 A 50 A | 400 A 90 A 50 A |
| Breaking capacity I_{cn} ($\cos\phi = 0,8$) AC, $U_e = 720$ V ($f = 50$ Hz) AC, $U_e = 1,200$ V ($f = 50$ Hz) AC, $U_e = 1,800$ V ($f = 50$ Hz) | 450 A 250 A 150 A | 450 A 250 A 150 A | 450 A 250 A 150 A |
| Breaking capacity I_{cn} ($\cos\phi = 1$) AC, $U_e = 720$ V ($f = 50$ Hz) AC, $U_e = 1,200$ V ($f = 50$ Hz) AC, $U_e = 1,800$ V ($f = 50$ Hz) | 800 A 450 A 250 A | 800 A 450 A 250 A | 800 A 450 A 250 A |
| Rated short-time withstand current I_{cw} ($T < 100$ ms) | 2.4 kA | 2.4 kA | 2.3 kA |
| Critical current range | None | None | None |
| Main contacts Contact material Terminals Torque | AgSnO ₂ M8 6 Nm max. | | |
| Aux. contacts Number of and type Contact material S870 breaking capacity ($T = 5$ ms) Terminals | 2x S870 Silver / Gold DC13: 110 V / 0.2 A / 24 V / 2 A Flat tabs 6.3 x 0.8 mm | | |
| Magnetic drive Pollution degree / Overvoltage category Coil voltage U_s Coil tolerance Power consumption at U_s and $T_a = 20^\circ$ C cold / warm coil Pull-in time, at $T_a = 20^\circ$ C typ. Drop-off voltage, at $T_a = 20^\circ$ C typ. Drop-off time, at $T_a = 20^\circ$ C typ. Switching frequency at $T_a = 20^\circ$ C and $1.25 U_s$ Coil suppression Coil terminals | < 29 W / < 21 W | PD3 / OV2 24 / 72 / 110 V DC -30 % ... +25 % U_s < 31 W / < 22 W 80 ms 0.1 ... 0.4 x U_s < 50 ms 4 operations/minute Suppressor diode M4 screws | < 42 W / < 30 W |
| Ingress protection rating (IP code) | IP00 | | |
| Mechanical endurance | > 3 million operating cycles | | |
| Vibration / Shock (EN 61373) | Category 1, Class B | | |
| Mounting orientation | Horizontal / Vertical | | |
| Ambient conditions Operating / Storage temperature Altitude Humidity (EN 50125-1) | -40 °C ... +70 °C / -40 °C ... +85 °C < 2,000 m above sea level < 75 % yearly average | | |
| Weight | < 2.7 kg | < 4.9 kg | < 7.6 kg |

CL1115/02 1 poles NO contactor – Dimensions, mounting, circuit diagram

Series CL

• **Dimensions**

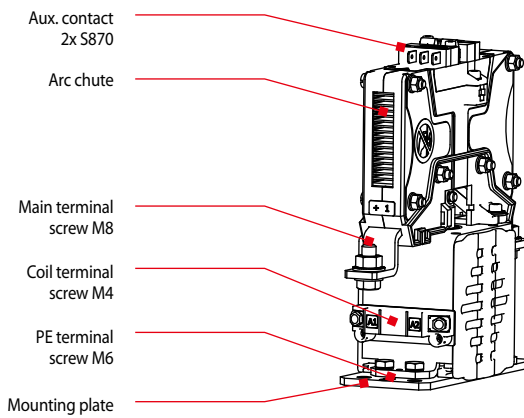
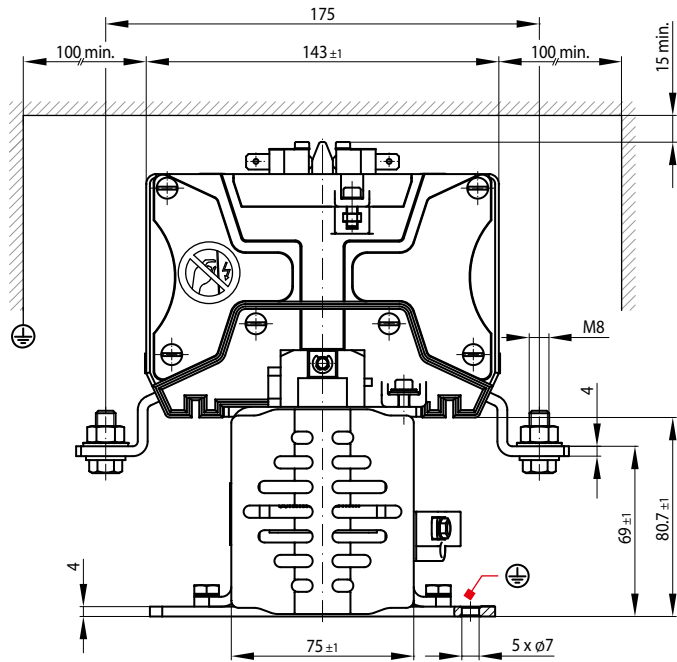
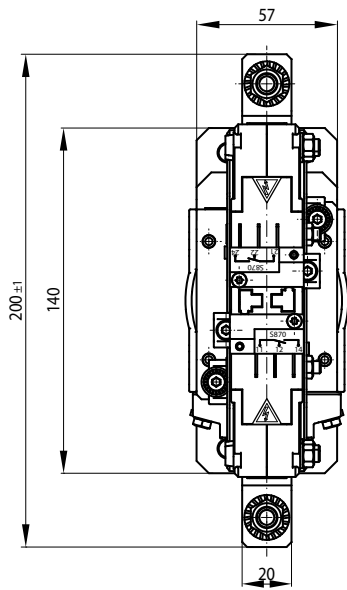
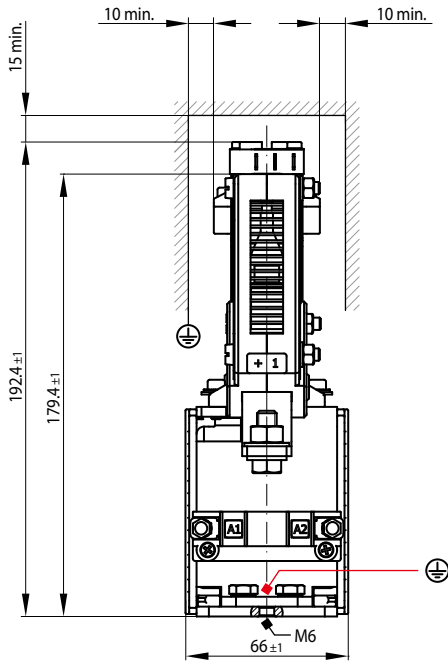

• **Mounting holes**

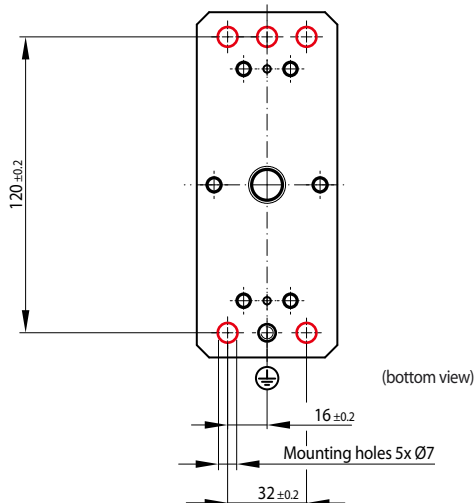

• **Circuit diagram**

DC contactors: polarity sensitive main contacts »P«

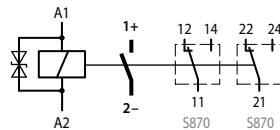

AC contactors: non-polarity sensitive main contacts »X«

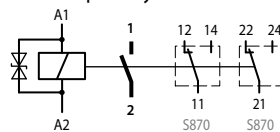

CL1215/02 2 poles NO contactor – Dimensions, mounting, circuit diagram

Series CL

• **Dimensions**

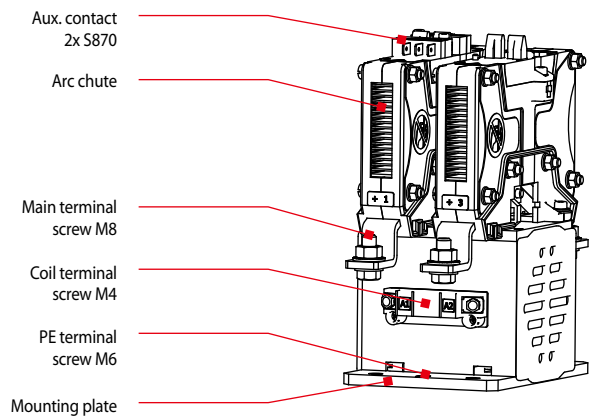
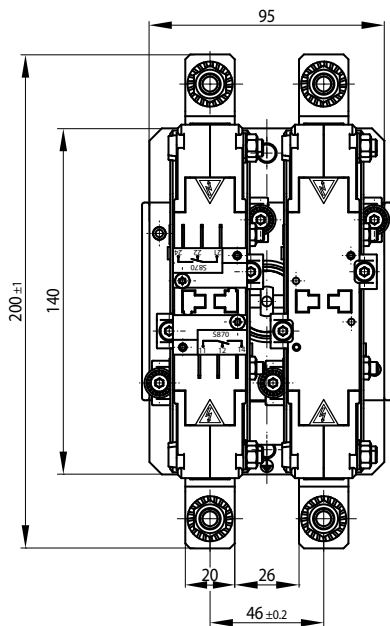
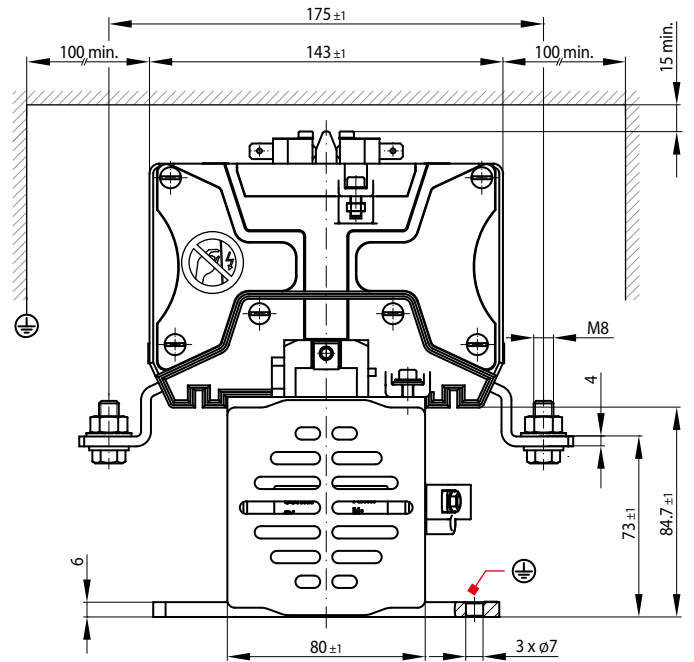
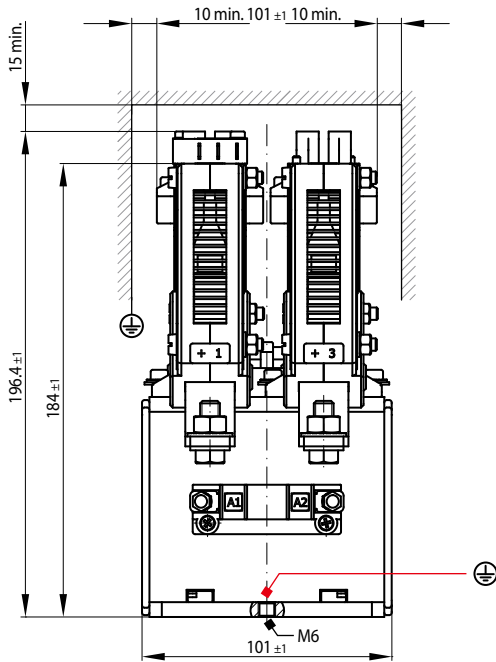

• **Mounting holes**

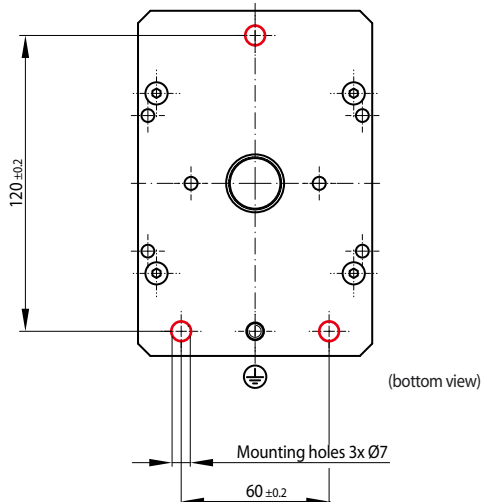

• **Circuit diagram**

DC contactors: polarity sensitive main contacts »P«

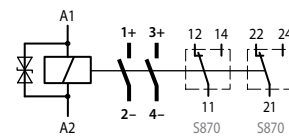

DC contactors: polarity sensitive main contacts »G«

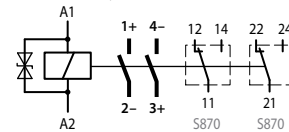

AC contactors: non-polarity sensitive main contacts »X«

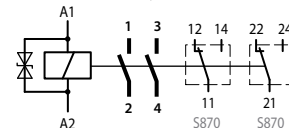

CL1315/02 3 pole NO contactor – Dimensions, mounting, circuit diagram

Series CL

• **Dimensions**

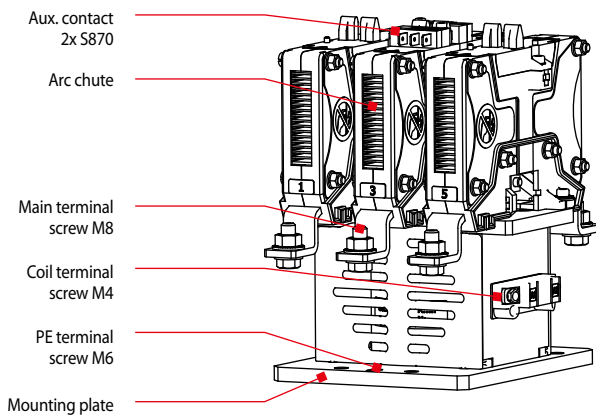
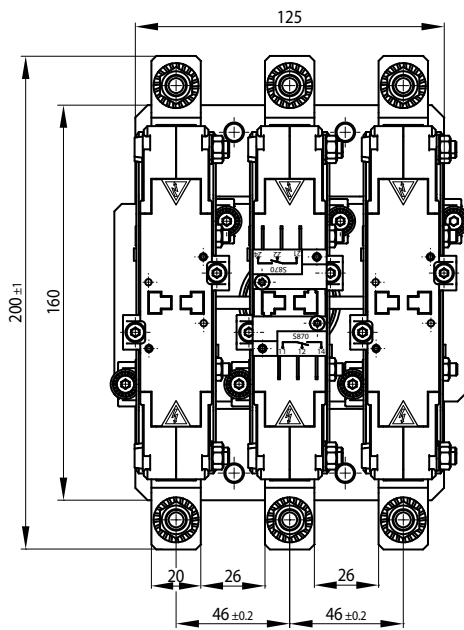
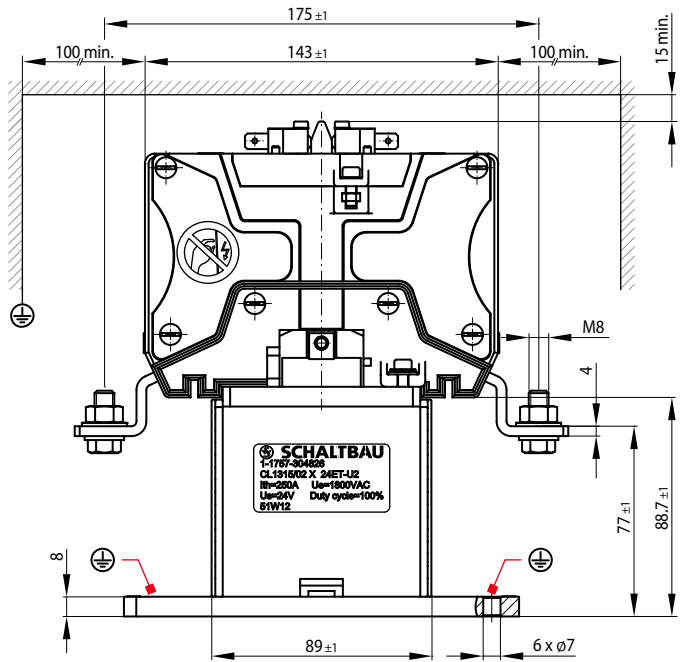
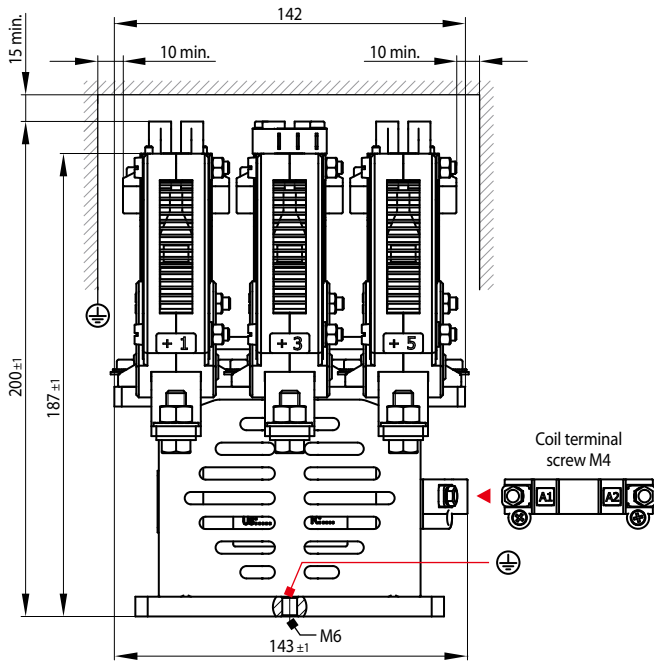

• **Mounting holes**

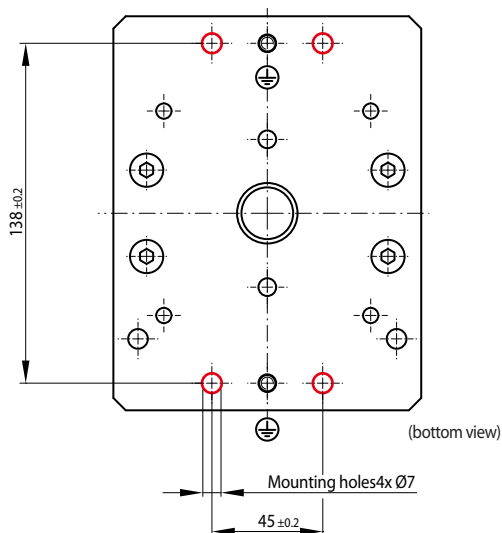

• **Circuit diagram**

AC contactor: non-polarity sensitive main contacts »X«

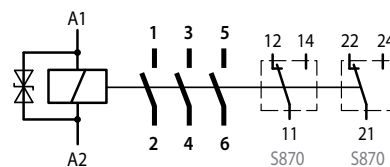

Mounting instructions

Mounting

CL Series contactors can be mounted horizontally or vertically. Use mounting plates or mounting frames which are strong enough to carry the weight of the contactor even under shock and vibration. This is especially true for use of the contactors in the rough railway environment.

Depending on the number of contacts, the contactors are to be affixed with 3 or 4 M6 screws. Use suitable screws with washers and observe tightening torque of the mounting screws:

| | | |
|-------------|------------------|-----------------------------------|
| • CL1115/02 | 3 x M6 or 4 x M6 | } Tightening torque 10 Nm max. |
| • CL1215/02 | 3 x M6 | |
| • CL1315/02 | 4 x M6 | |

Mounting orientations

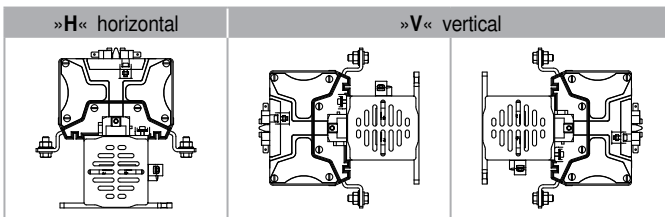

Electrical requirements

- Observe clearance to non-insulated live parts and earth.
- When switching high loads, the minimum time between switching operations is 30 seconds. After 3 switching operations make sure that there is a fault closure for 10 minutes.
- To prevent flashovers and excessive contact wear, ensure adequate ventilation of the contactor.
- Observe the minimum cross sections of wires and current bars that are to be connected to the main terminals of the contactor and to its PE terminal.

Spare parts

| Items | Description | Ordering code |
|-------|---|---------------|
| 1 | AC arc chute, complete with fixed contacts and contact bridge | 1-2757-336205 |
| 1 | DC arc chute, complete with fixed contacts and contact bridge | 1-2757-336206 |
| 1 | S870 Series auxiliary switch | 1-1570-198424 |

Standards

- **IEC 60077:** Railway applications – Electric equipment for rolling stock
- **EN 50124-1:** Railway applications – Insulation coordination – Part 1: Basic requirements – Clearances and creepage distances for all electrical and electronic equipment
- **IEC 61373:** Railway applications - Rolling stock equipment - Shock and vibration tests

Safety instructions

Series CL

- The switching device meets the requirements of basic insulation. Make sure the plate onto which the drive of the contactor is mounted is earthed in a vibration resistant way.
- Do not use contactor without properly mounted arc chute.
- The contactor has non-insulated live parts and carries a label that warns of the hazard. This caution must be observed and the label must not be removed in any way.
- Observe the required clearance of live parts to ground and other parts of the contactor as well as the safety regulations of the applicable standards.
- Switching at maximum breaking capacity might require larger clearance! Do not hesitate to ask our advice for dimensioning.
- Coil suppression for reducing surges when the coil is switched off is optimally attuned to the contactor's switching behaviour. The existing opening characteristic must not be negatively influenced by parallel connection with an external diode.
- Improper handling of the contactor, e.g. when hitting the floor with some impact, can result in breakage, visible cracks and deformation.



Defective parts must be replaced immediately!

Maintenance instructions



For detailed maintenance, safety and mounting instructions please refer to our operating manual C25/02-M.en!

- CL Series contactors are maintenance free with normal use.
- Make regular inspections once or twice a year. So when installing the contactor, make sure that there is enough space to remove and replace the arc chute with ease and that the main contacts become accessible for inspection.
- Frequent switching or switching under high load may lead to increased wear of the main contacts. In this case replacement of the main contacts may become necessary.

Schaltbau GmbH

For detailed information on our products and services visit our website – or give us a call!

Schaltbau GmbH
Hollerithstrasse 5
81829 Munich
Germany



Phone +49 89 9 30 05-0
Fax +49 89 9 30 05-350
Internet www.schaltbau-gmbh.com
e-Mail contact@schaltbau.de

with compliments:



Schaltbau GmbH manufactures in compliance with RoHS.



The production facilities of Schaltbau GmbH have been IRIS certified since 2008.



Certified to DIN EN ISO 14001 since 2002. For the most recent certificate visit our website.



Certified to DIN EN ISO 9001 since 1994. For the most recent certificate visit our website.

Electrical Components and Systems for Railway Engineering and Industrial Applications

Connectors

- Connectors manufactured to industry standards
- Connectors to suit the special requirements of communications engineering (MIL connectors)
- Charging connectors for battery-powered machines and systems
- Connectors for railway engineering, including UIC connectors
- Special connectors to suit customer requirements

Snap-action switches

- Snap-action switches with positive opening operation
- Snap-action switches with self-cleaning contacts
- Enabling switches
- Special switches to suit customer requirements

Contactors

- Single and multi-pole DC contactors
- High-voltage AC/DC contactors
- Contactors for battery powered vehicles and power supplies
- Contactors for railway applications
- Terminal bolts and fuse holders
- DC emergency disconnect switches
- Special contactors to suit customer requirements

Electrics for rolling stock

- Equipment for driver's cab
- Equipment for passenger use
- High-voltage switchgear
- High-voltage heaters
- High-voltage roof equipment
- Equipment for electric brakes
- Design and engineering of train electrics to customer requirements