

3

Contactors

CT1215/04, CT1230/04
CT1215/08, CT1230/08
CT1215/11, CT1230/11

1 pole
AC and bi-directional DC
NO contactors for
400 A, 800 A and 1,100 A

Catalogue C21.en

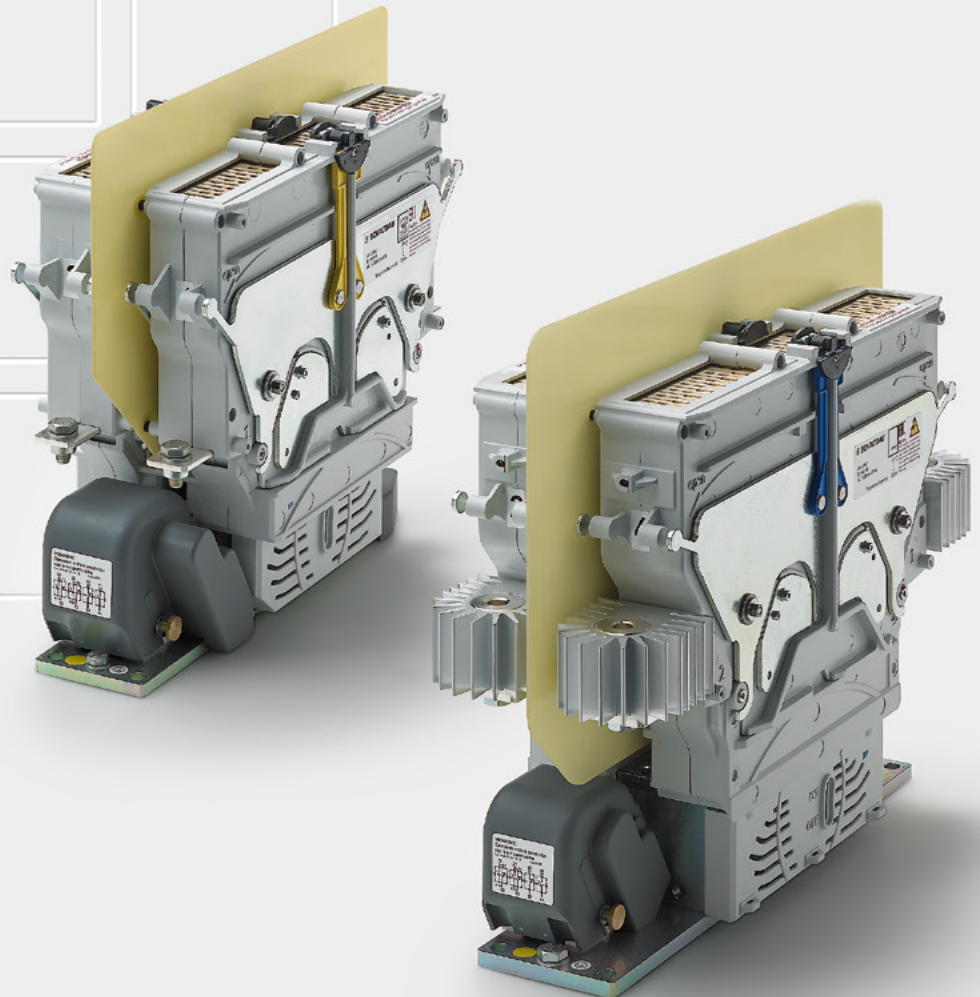

More information
schaltbau.com

CT1215/04, CT1230/04 Double pole power contactors for AC and DC, 400 A, 1,500 V oder 3,000 V
CT1215/08, CT1230/08 Double pole power contactors for AC and DC, 800 A, 1,500 V oder 3,000 V
CT1215/11, CT1230/11 Double pole power contactors for AC and DC, 1,100 A, 1,500 V oder 3,000 V

CT series – revolutionary method of arc quenching for both DC and AC

With the double pole CT series contactors Schaltbau expands its product line of state-of-the-art power contactors. The outstanding technical feature is the innovative combination of electromagnetic and permanent-magnetic blowout technology for electric arc control. The successful combination of these two principles greatly improves both switching functionality, reliability and forms a practical and economically impressive device concept.

The CT contactor concept is flexible and can be adapted to suit the needs of the customer. Due to its technical characteristics, its economical advantages, its compactness and versatility, the CT power contactor series is simply predestined for use in industrial and railway applications alike. The contactors are especially suited for use in locomotives, cranes, and converters of wind turbines and PV installations, but also in mining.

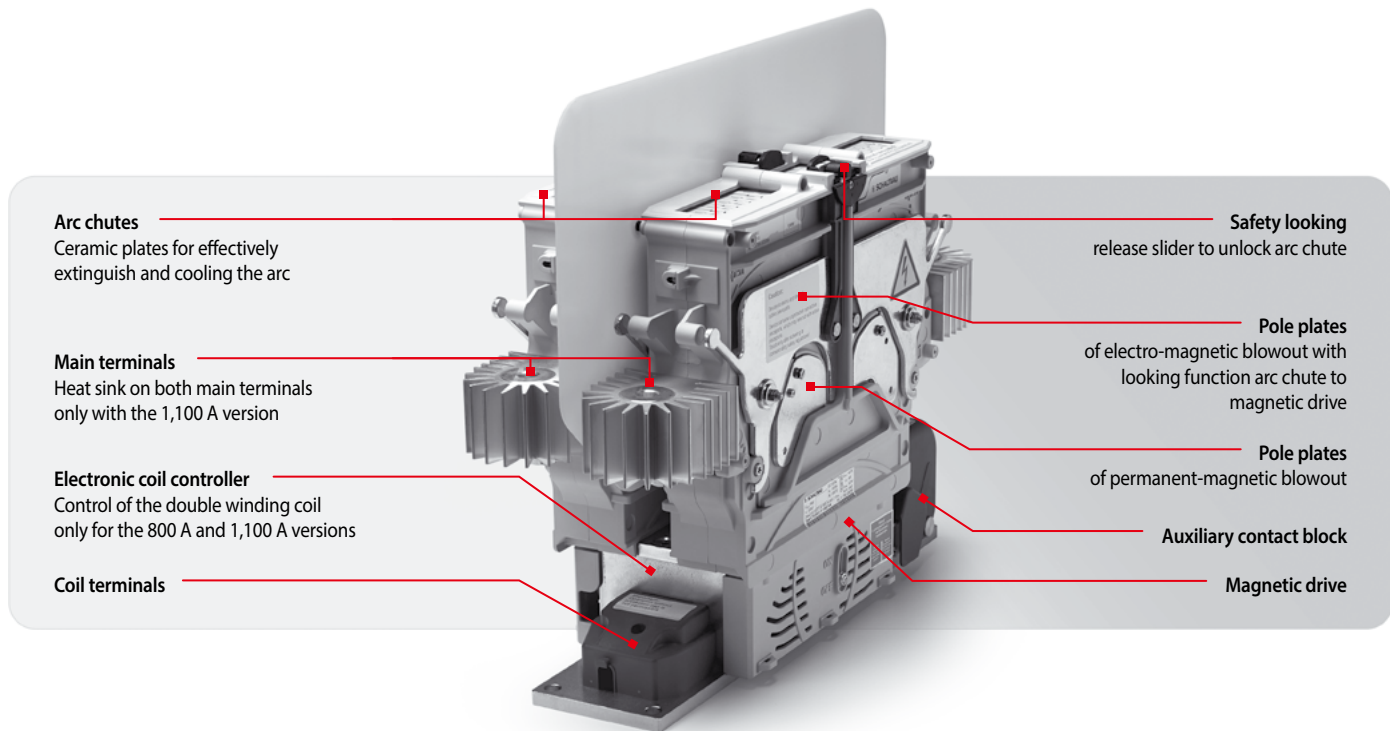

Arc chutes
Ceramic plates for effectively extinguish and cooling the arc

Main terminals
Heat sink on both main terminals only with the 1,100 A version

Electronic coil controller
Control of the double winding coil only for the 800 A and 1,100 A versions

Coil terminals

Safety locking
release slider to unlock arc chute

Pole plates
of electro-magnetic blowout with locking function arc chute to magnetic drive

Pole plates
of permanent-magnetic blowout



Auxiliary contact block

Magnetic drive

Features

- **Innovative design:**

 - 1 pole NO contactors, DC bidirectional or AC
 - Contactors for 400 A, 800 A or 1,100 A current rating
 - Nominal voltage 1,500 V or 3,000 V
 - Double-break contacts
 - Reliable shutdown of smaller currents at higher voltages – no critical current range
 - Compact, rugged design
- **Universal use:**

 - Drive system with coil tolerance according to railway standards
 - CCC approval for CT12xx/04, CT12xx/08 and CT12xx/11 
 - UL approval available for selected versions  **us**, a list of all UL types can be found here:
➔ schaltbau.info/ct-group-en
- **Excellent insulation properties:**

 - Reinforced insulation between main circuit and control circuit/auxiliary circuit
- **Easy maintenance:**

 - Easy inspection and replacement of main contact tips
 - Easy to replace arc chute

Applications

- **Main contactor for:**

 - Traction converters
 - Inverters for auxiliary equipment
- **Contactor for:**

 - Field circuits of motors
 - Conventional resistor based traction units (retrofit)
 - Starter and compressor motors
 - Heating circuits
- **Contactor for a host of industrial and railway applications:**

 - Locomotives
 - Cranes
 - Mining

Competence

The success of a product is owed to its quality

The Schaltbau product line is clearly defined and keeps up with the technological requirements of today's markets. Behind every individual contactor you will find decades of experience in engineering and manufacturing. Contactors are remote-controlled electrical switches with which high currents and voltages can be switched. A control current activates the magnetic drive that closes and reopens the contacts of the load current circuit. The moment of switching off represents a special challenge. The air between the opening contacts becomes ionised and an electric arc is created in which the current continues to flow. The air between the contacts offers a great deal of electrical resistance, which creates temperatures of up to

10,000 °C. To prevent the contacts or even the entire device from being thermal destroyed, the electric arc must be driven out of the contact area into arc chambers to be stretched and cooled until it loses energy and finally dies out. In order to extinguish the electric arc within a few milliseconds we have incorporated some sophisticated solutions in our contactors. This experience helps us to develop reliable contactors for power plants, computer centres and electrically powered vehicles.

Ordering code

Example: **CT1230/04 H 110ET-00**

Series, contact configuration		Auxiliary switches, number and type	
CT11	1 pole NO contactor *1	M3 screw-type terminals	{ 1x S870*2 (a1) 00 1x S870*2 (b0) 2x S826 a L*3
CT12	2 pole NO contactor	M3 screw-type terminals	{ 1x S870*2 (a1) 01 1x S870*2 (b0)
Nominal voltage		Flat tabs 6.3 x 0.8 mm	{ 2x S826*3
15	U _n = 1,500 V	M3 screw-type terminals	{ 4x S826*3 02
30	U _n = 3,000 V	Flat tabs 6.3 x 0.8 mm	{ 4x S826*3 03
Conv. thermal current			
04	I _{th} = 400 A		
08	I _{th} = 800 A		
11	I _{th} = 1,100 A		
Mounting position			
H	horizontal (lock bar yellow), for coil suppression T only		
V	vertical (lock bar red), for coil suppression T only		
N	horizontal or vertical (lock bar blue), for coil suppression CM only		
Coil voltage			
24 / 36 / 48 / 72 / 110 V DC			
Coil tolerance			
E -30 % ... +25 %			
Coil suppression			
T	Suppressor diode, (CT12xx/04 only)		
CM	Double coil controller with integrated suppressor diode for magnetic drives with double winding coil, (CT12xx/08, CT12xx/11 only)		

*1 See catalogue C21 *2 See also catalogue D70 *3 See also catalogue D26

i Do you need support for a special application? Please contact us! We would be glad to assist you in the selection of the contactor that suits your application best.

i Presented in this catalogue are only stock items which can be supplied in short delivery time. For some variants minimum quantities apply. Please do not hesitate to ask for the conditions. **Special variant:** If you need a special variant of the contactor, please do not hesitate to contact us. Maybe the type of contactor you are looking for is among our many special designs. If not, we can also supply customized designs. In this case, however, minimum order quantities apply.

Standards

- IEC 60077-2 Railway applications – Electric equipment for rolling stock – Part 2: Electrotechnical components; General rules
- IEC 62497-1 Railway applications – Insulation coordination – Part 1: Basic requirements – Clearances and creepage distances for all electrical and electronic equipment
- IEC 61373 Railway applications – Rolling stock equipment – Shock and vibration tests
- IEC 60947-4-1 Low-voltage switchgear and controlgear – Part 4-1: Contactors and motor-starters – Electromechanical contactors and motor-starters
- IEC 62236-3-2 Railway applications – Electromagnetic compatibility – Part 3-2: Rolling stock – Apparatus

Specifications Double pole power contactors for AC and DC, Nominal voltage = 1,500 V

CT series

Series		CT1215/04	CT1215/08	CT1215/11
Type of voltage		DC (bidirectional), AC (f ≤ 60 Hz)		
Number of poles, configuration		2x SPST-NO		
Electrical ratings of main circuit to IEC 60077-2				
Nominal voltage	U _n	1,500 V	1,500 V	1,500 V
Rated operating voltage	U _r	1,800 V	1,800 V	1,800 V
Rated insulation voltage	U _{Nm}	3,000 V	3,000 V	3,000 V
Rated impulse withstand voltage	U _{Ni}	15 kV	15 kV	15 kV
Pollution degree / Overvoltage category		PD3 / OV2	PD3 / OV2	PD3 / OV2
Switching overvoltages	@ U _e = 1,800 V	<9 kV (<11 kV @ T2 = 40 ms)	<9 kV (<11 kV @ T2 = 40 ms)	<9 kV (<11 kV @ T2 = 40 ms)
Conventional thermal current	I _{th}	400 A *1	800 A	1,100 A
Component category		A2	A2	A2
Short-circuit making capacity, new/used contacts		2.5 kA / 5 kA	3.5 kA / 8 kA	3.5 kA / 8 kA
Rated operating current I _e	(2 poles in series, @ operational frequency C2) DC, U _e = 1,800 V (T2 = 15 ms) DC, U _e = 3,600 V (T2 = 15 ms)	450 A ---	800 A ---	800 A ---
Rated operating current I _e	(per pole, @ operational frequency C2) DC, U _e = 1,800 V (T2 = 15 ms) DC, U _e = 3,600 V (T2 = 15 ms)	300 A ---	450 A ---	450 A ---
Rated short-circuit breaking capacity (T2 = 15 ms)	DC, U _e = 1,200 V DC, U _e = 1,800 V DC, U _e = 3,600 V	1,400 A 800 A ---	2,000 A 1,400 A ---	2,000 A 1,400 A ---
Rated short-circuit breaking capacity (T2 = 1 ms)	DC, U _e = 1,200 V DC, U _e = 1,800 V DC, U _e = 3,600 V	2,600 A 1,800 A ---	4,200 A 3,000 A ---	4,200 A 3,000 A ---
Rated short-circuit breaking capacity (cosφ = 0.8)	AC, U _e = 1,200 V (f = 16.7 / 50 Hz) AC, U _e = 1,800 V (f = 16.7 / 50 Hz) AC, U _e = 3,600 V (f = 16.7 / 50 Hz)	1,000 A / 700 A 800 A / 500 A --- / ---	1,900 A / 1,400 A 1,500 A / 1,000 A --- / ---	1,900 A / 1,400 A 1,500 A / 1,000 A --- / ---
Rated short-circuit breaking capacity (cosφ = 1)	AC, U _e = 1,200 V (f = 16.7 / 50 Hz) AC, U _e = 1,800 V (f = 16.7 / 50 Hz) AC, U _e = 3,600 V (f = 16.7 / 50 Hz)	1,300 A / 1,000 A 1,000 A / 700 A --- / ---	2,200 A / 1,600 A 1,900 A / 1,200 A --- / ---	2,200 A / 1,600 A 1,900 A / 1,200 A --- / ---
Rated short-time withstand current I _{cw}	per Pol, T < 100 ms	5 kA (T < 100 ms)	8 kA (T < 100 ms) *2	8 kA (T < 100 ms), 20 kA (T < 20 ms)
Critical current range		None	None	None
Design				
Contact material		AgSnO ₂	AgSnO ₂	AgSnO ₂
Terminals / Torque		M10 / 16 ... 20 Nm	M12 / 24 ... 30 Nm	M12 / 24 ... 30 Nm
Auxiliary contacts				
Number and type		1x S870 (a ₁)*4, 1x S870 (b ₀)*4, 2x S826 or 4x S826		
Contact material		Silver		
Switching capacity	S826, T = 5 ms	16 A @ 24 V DC; 13.5 A @ 80 V DC; 7 A @ 110 V DC		
Terminals		Screws M3 / Flat tabs 6.3 x 0.8 mm		
Magnetic drive (monostable)				
Coil voltage	U _s	24 / 36 / 48 / 72 / 110 V DC	24 / 36 / 48 / 72 / 110 V DC	24 / 36 / 48 / 72 / 110 V DC
Pollution degree / overvoltage category		PD3 / OV2	PD3 / OV2	PD3 / OV2
Coil tolerance		-30 % ... +25 % U _s	-30 % ... +25 % U _s	-30 % ... +25 % U _s
Coil power dissipation	@ U _s and T _a = 20 °C	Cold coil 70 W Warm coil 50 W	Pull-in (1 s max.) 280 W Hold 27 W	Pull-in (1 s max.) 330 W Hold 50 W
Pull-in voltage, typical	@ T _a = 20 °C	0.6 x U _s	0.6 x U _s	0.6 x U _s
Pull-in time, typical	@ T _a = 20 °C	85 ms	95 ms	130 ms *2
Drop-off voltage, typical	@ T _a = 20 °C	> 0.08 x U _s	> 0.08 x U _s	> 0.08 x U _s
Drop-off time, typical	@ T _a = 20 °C	50 ms	95 ms	100 ms
Coil design / Coil suppression		Standard coil	Double winding coil	Double winding coil
Suppressor diode		●	●	---
Double coil controller with integrated suppressor diode		---	---	●
Coil terminal		Cage clamp	Cage clamp	Cage clamp
Degree of protection				
IP00				
Mechanical endurance				
		> 2 million operating cycles	> 2 million operating cycles	> 1 million operating cycles
Vibration / shock				
IEC 61373		Category 1, class B		
Mounting position				
		horizontal / vertical		
Temperatures				
Operating temperature / Storage temperature Altitude / Humidity (EN 50125-1)		-40 °C ... +70 °C / -40 °C ... +85 °C < 2,000 m above sea level / < 75 % yearly average		
Weight				
		11 kg	18 kg	20 kg

 SCHALTBAU

*1 With frequent switching under load the conv. thermal current I_{th} must be limited to 350 A.

*2 Preliminary values

*3 Observe dimensioning instructions for CT1230/08 Series on page 10

*4 a₁ and b₀ according to IEC60077-2 (Aux. contact b₀ „well open“ or mirror contact for feedback circuits of safety-relevant controls according to DIN EN 13849-1)

*5 For frequent load switching use contactors for vertical mounting (red lock bars).

Specifications Double pole power contactors for AC and DC, Nominal voltage = 3,000 V

CT series

Series		CT1230/04	CT1230/08	CT1230/11
Type of voltage		DC (bidirectional), AC (f ≤ 60 Hz)		
Number of poles, configuration		2x SPST-NO		
Electrical ratings of main circuit to IEC 60077-2				
Nominal voltage	U _n	3,000 V	3,000 V	3,000 V
Rated operating voltage	U _r	3,600 V	3,600 V	3,600 V
Rated insulation voltage	U _{Nm}	4,800 V	4,800 V	4,800 V
Rated impulse withstand voltage	U _{Ni}	25 kV	25 kV	25 kV
Pollution degree / Overvoltage category		PD3 / OV2	PD3 / OV2	PD3 / OV2
Switching overvoltages	@ U _e = 1,800 V	< 14.4 kV	< 15 kV	< 15 kV
Conventional thermal current	I _{th}	400 A *1	800 A	1,100 A
Component category		A2	A2	A2
Short-circuit making capacity, new/used contacts		3.5 kA / 5 kA	4 kA / 8 kA	4 kA / 8 kA
Rated operating current I _e	(2 poles in series, @ operational frequency C2) DC, U _e = 1,800 V (T2 = 15 ms) DC, U _e = 3,600 V (T2 = 15 ms)	---	---	---
		350 A (extrapolated value)	800 A	800 A
Rated operating current I _e	(per pole, @ operational frequency C2) DC, U _e = 1,800 V (T2 = 15 ms) DC, U _e = 3,600 V (T2 = 15 ms)	---	---	---
		200 A	320 A	320 A
Rated short-circuit breaking capacity (T2 = 15 ms)	DC, U _e = 1,200 V DC, U _e = 1,800 V DC, U _e = 3,600 V	---	---	---
		1,200 A 750 A	2,000 A 1,200 A *3	2,000 A 1,200 A
Rated short-circuit breaking capacity (T2 = 1 ms)	DC, U _e = 1,200 V DC, U _e = 1,800 V DC, U _e = 3,600 V	---	---	---
		2,900 A 1,400 A	3,400 A 2,300 A *3	3,400 A 2,300 A
Rated short-circuit breaking capacity (cosφ = 0.8)	AC, U _e = 1,200 V (f = 16.7 / 50 Hz) AC, U _e = 1,800 V (f = 16.7 / 50 Hz) AC, U _e = 3,600 V (f = 16.7 / 50 Hz)	--- / --- 1,600 A / 900 A 900 A / 500 A	--- / --- 2,300 A / 1,500 A 1,300 A / 900 A	--- / --- 2,300 A / 1,500 A 1,300 A / 900 A
Rated short-circuit breaking capacity (cosφ = 1)	AC, U _e = 1,200 V (f = 16.7 / 50 Hz) AC, U _e = 1,800 V (f = 16.7 / 50 Hz) AC, U _e = 3,600 V (f = 16.7 / 50 Hz)	--- / --- 2,100 A / 1,200 A 1,300 A / 800 A	--- / --- 2,900 A / 1,700 A 1,600 A / 1,300 A	--- / --- 2,900 A / 1,700 A 1,600 A / 1,300 A
Rated short-time withstand current I _{cw}	per Pol, T < 100 ms	6 kA	8 kA *2	8 kA *2
Critical current range		None	None	None
Design				
Contact material		AgSnO ₂	AgSnO ₂	AgSnO ₂
Terminals / Torque		M10 / 16 ... 20 Nm	M12 / 24 ... 30 Nm	M12 / 24 ... 30 Nm
Auxiliary contacts				
Number and type		1x S870 (a ₁)*4, 1x S870 (b ₀)*4, 2x S826 or 4x S826		
Contact material		Silver		
Switching capacity	S826, T = 5 ms	16 A @ 24 V DC; 13.5 A @ 80 V DC; 7 A @ 110 V DC		
Terminals		Screws M3 / Flat tabs 6.3 x 0.8 mm		
Magnetic drive (monostable)				
Coil voltage	U _s	24 / 36 / 48 / 72 / 110 V DC	24 / 36 / 48 / 72 / 110 V DC	24 / 36 / 48 / 72 / 110 V DC
Pollution degree / overvoltage category		PD3 / OV2	PD3 / OV2	PD3 / OV2
Coil tolerance		-30 % ... +25 % U _s	-30 % ... +25 % U _s	-30 % ... +25 % U _s
Coil power dissipation	@ U _s and T _a = 20 °C	Cold coil 70 W Warm coil 50 W	Pull-in (1 s max.) 280 W Hold 27 W	Pull-in (1 s max.) 330 W Hold 50 W
Pull-in voltage, typical	@ T _a = 20 °C	0.6 x U _s	0.6 x U _s	0.6 x U _s
Pull-in time, typical	@ T _a = 20 °C	120 ms	95 ms	95 ms
Drop-off voltage, typical	@ T _a = 20 °C	> 0.08 x U _s	> 0.08 x U _s	> 0.08 x U _s
Drop-off time, typical	@ T _a = 20 °C	60 ms	95 ms	95 ms
Coil design / Coil suppression		Standard coil	Double winding coil	Double winding coil
Suppressor diode		•	•	---
Double coil controller with integrated suppressor diode		---	---	•
Coil terminal		Cage clamp	Cage clamp	Cage clamp
Degree of protection				
		IP00		
Mechanical endurance				
		> 2 million operating cycles	> 2 million operating cycles	> 1 million operating cycles
Vibration / shock				
	IEC 61373	Category 1, class B		
Mounting position				
		horizontal / vertical		
Temperatures				
Operating temperature / Storage temperature		-40 °C ... +70 °C / -40 °C ... +85 °C		
Altitude / Humidity (EN 50125-1)		< 2,000 m above sea level / < 75 % yearly average		
Weight				
		13 kg	21 kg	23 kg



*1 With frequent switching under load the conv. thermal current I_{th} must be limited to 350 A.

*2 Preliminary values

*3 Observe dimensioning instructions for CT1230/08 Series on page 10

*4 a₁ and b₀ according to IEC60077-2 (Aux. contact b₀ „well open“ or mirror contact for feedback circuits of safety-relevant controls according to DIN EN 13849-1)

*5 For frequent load switching use contactors for vertical mounting (red lock bars).

CT1215/04 Dimension diagram double pole NO contactor for 1,500 V / 400 A

CT series

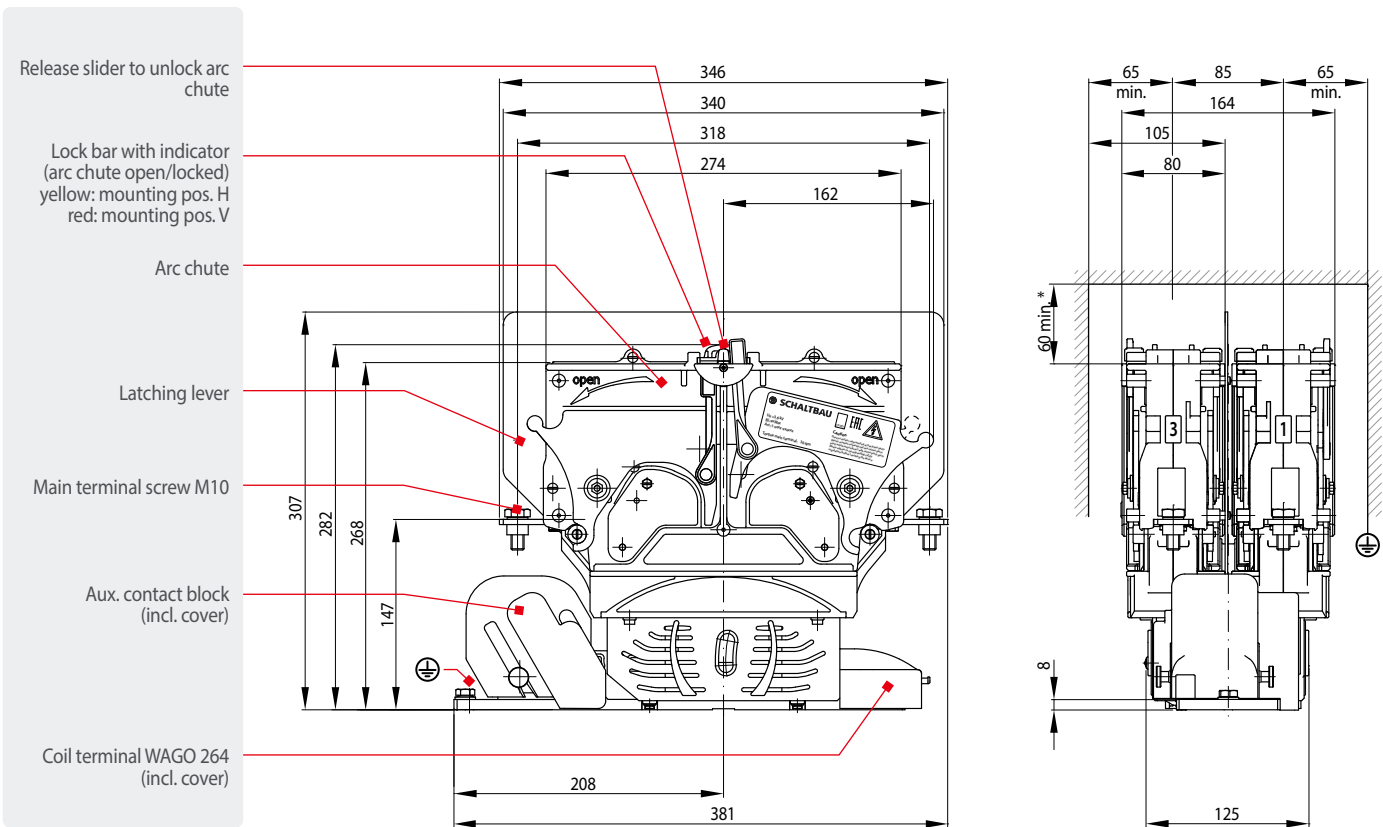

CT1215/08 Dimension diagram double pole NO contactor for 1,500 V / 800 A

CT series

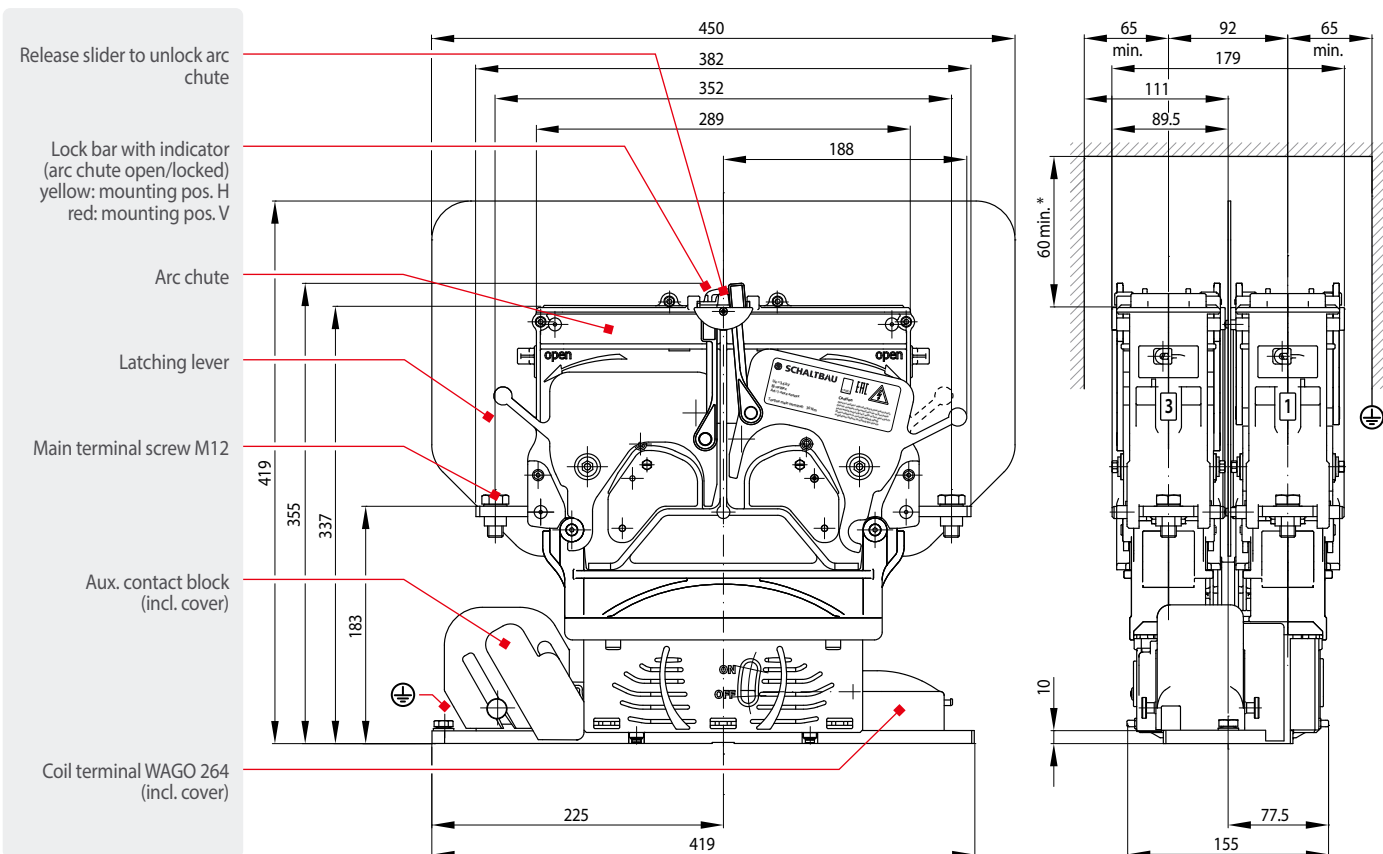

* Interrupting at maximum capacity could require larger clearance!
Feel free to contact us, we will be happy to assist you with dimensioning.

CT1230/04 Dimension diagram double pole NO contactor for 3,000 V / 400 A

CT series

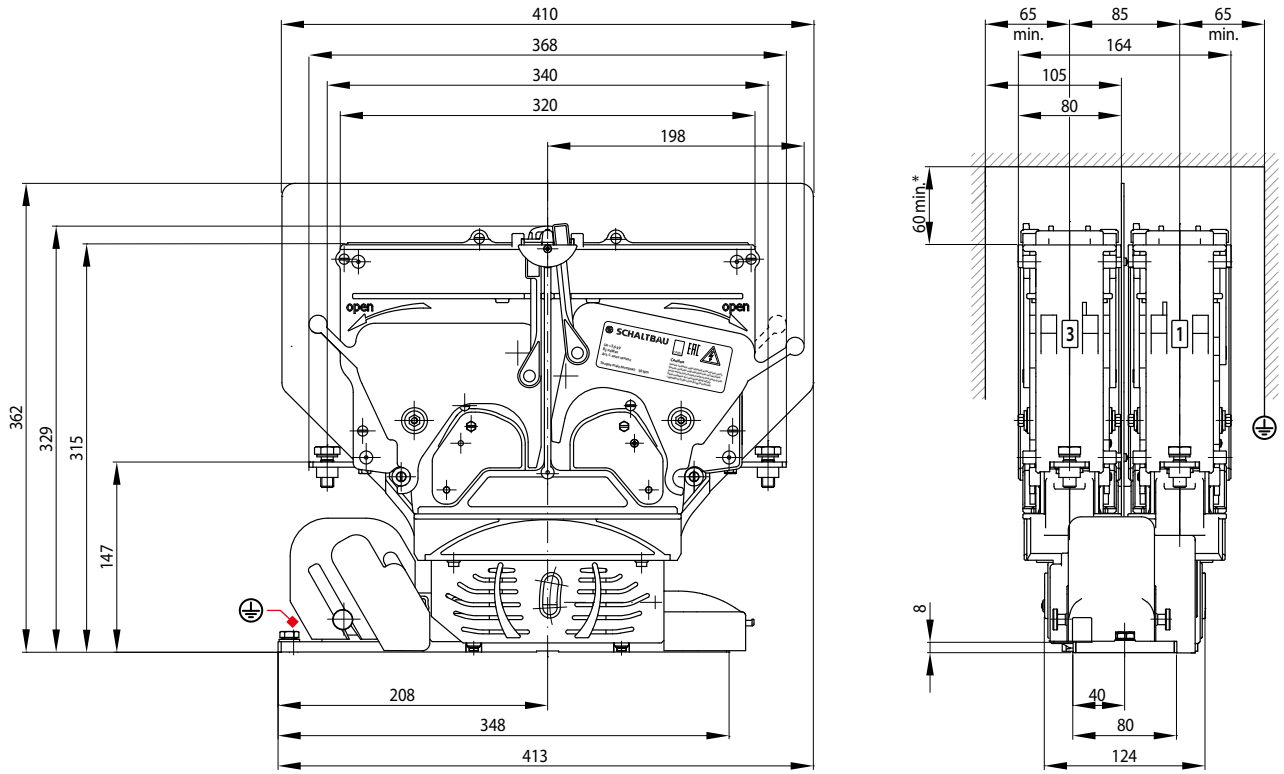

CT1230/08 Dimension diagram double pole NO contactor for 3,000 V / 800 A

CT series

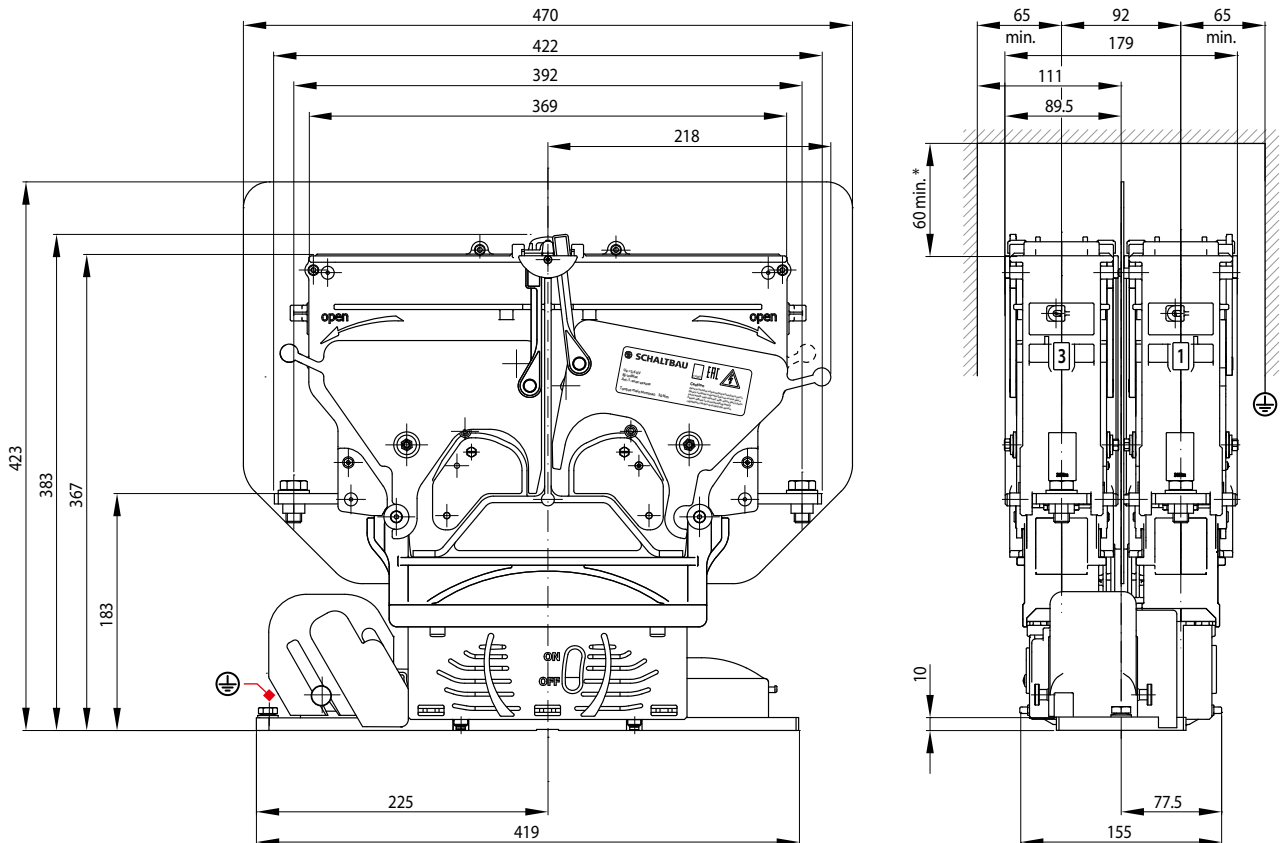

* Interrupting at maximum capacity could require larger clearance!
 Feel free to contact us, we will be happy to assist you with dimensioning.

Subject to change / Dimensions in mm

CT1215/11 Dimension diagram double pole NO contactor for 1,500 V / 1,100 A

CT series

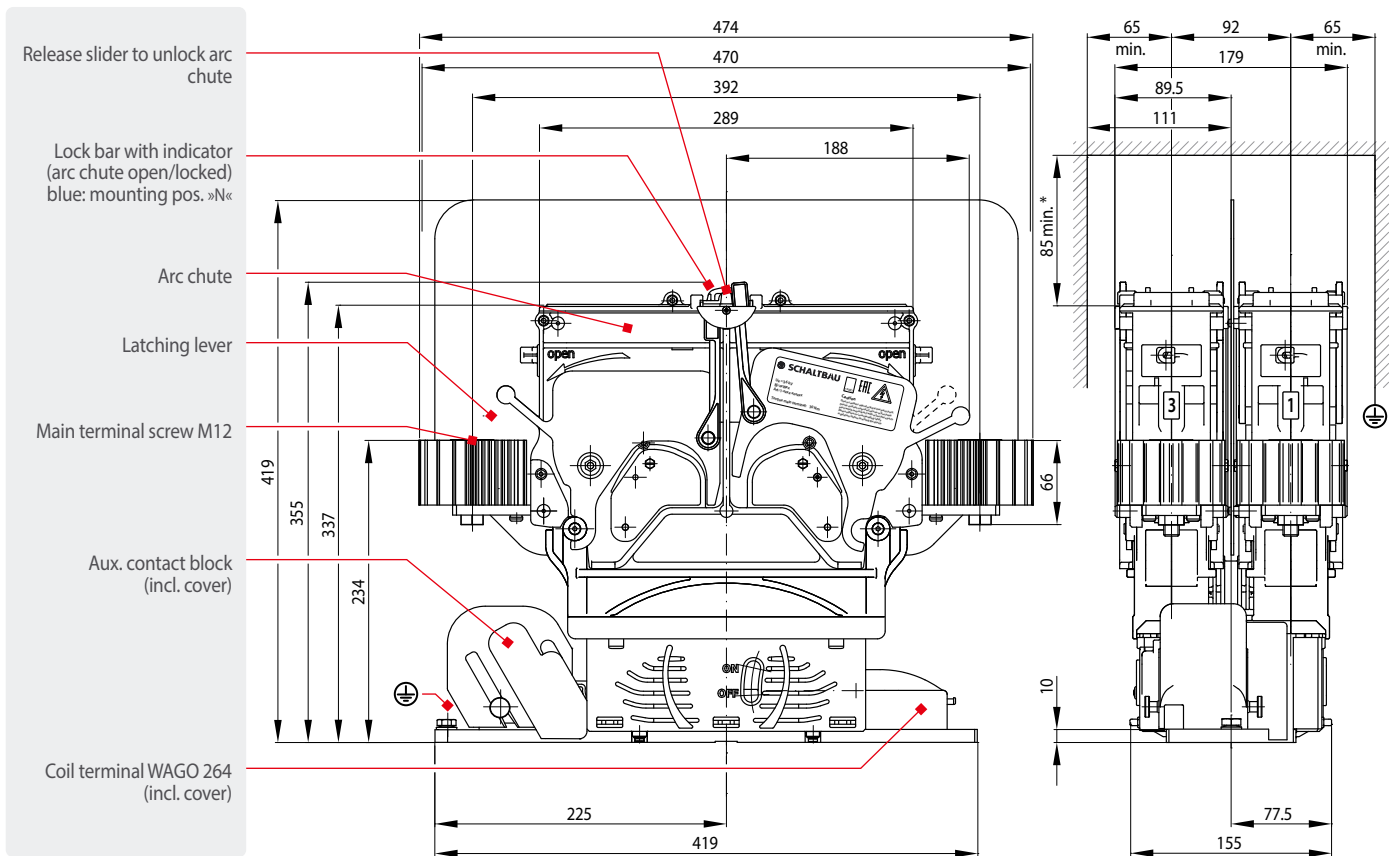

* Interrupting at maximum capacity could require larger clearance!
Feel free to contact us, we will be happy to assist you with dimensioning.

Circuit diagrams

CT series

- Versions according to railway standard for railway applications or with mirror contact for industrial applications

- Versions for industrial applications without mirror contact

CT1215/04, CT1230/04

Main contacts 2x NO, $I_{th} = 400$ A
 Aux. contacts (EN 60077) 2 x S826, 1 x S870(b0), 1 x S870(a1)
 Magnetic drive Coil suppression «T»
 Standard coil with suppressor diode

Circuit diagram

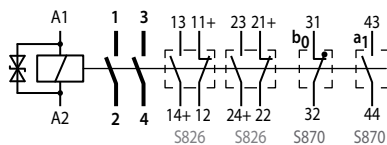

CT1215/04, CT1230/04

Main contacts 2x NO, $I_{th} = 400$ A
 Auxiliary contacts 4 x S826
 Magnetic drive Coil suppression «T»
 Standard coil with suppressor diode

Circuit diagram

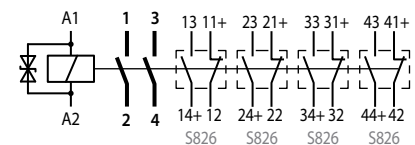

CT1215/08, CT1230/08, CT1215/11, CT1230/11

Main contacts 2x NO, $I_{th} = 800$ A / 1,100 A
 Aux. contacts (EN 60077) 2 x S826, 1 x S870(b0), 1 x S870(a1)
 Magnetic drive Coil suppression «CM»
 Double coil controller (DCC) with integrated suppressor diode for magnetic drives with double winding coil

Circuit diagram

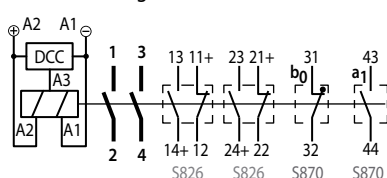

CT1215/08, CT1230/08, CT1215/11, CT1230/11

Main contacts 2x NO, $I_{th} = 800$ A / 1,100 A
 Auxiliary contacts 4 x S826
 Magnetic drive Coil suppression «CM»
 Double coil controller (DCC) with integrated suppressor diode for magnetic drives with double winding coil

Circuit diagram

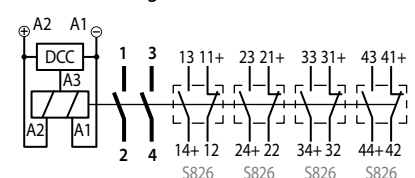

CT1230/11 Dimension diagram double pole NO contactor for 3,000 V / 1,100 A

CT series

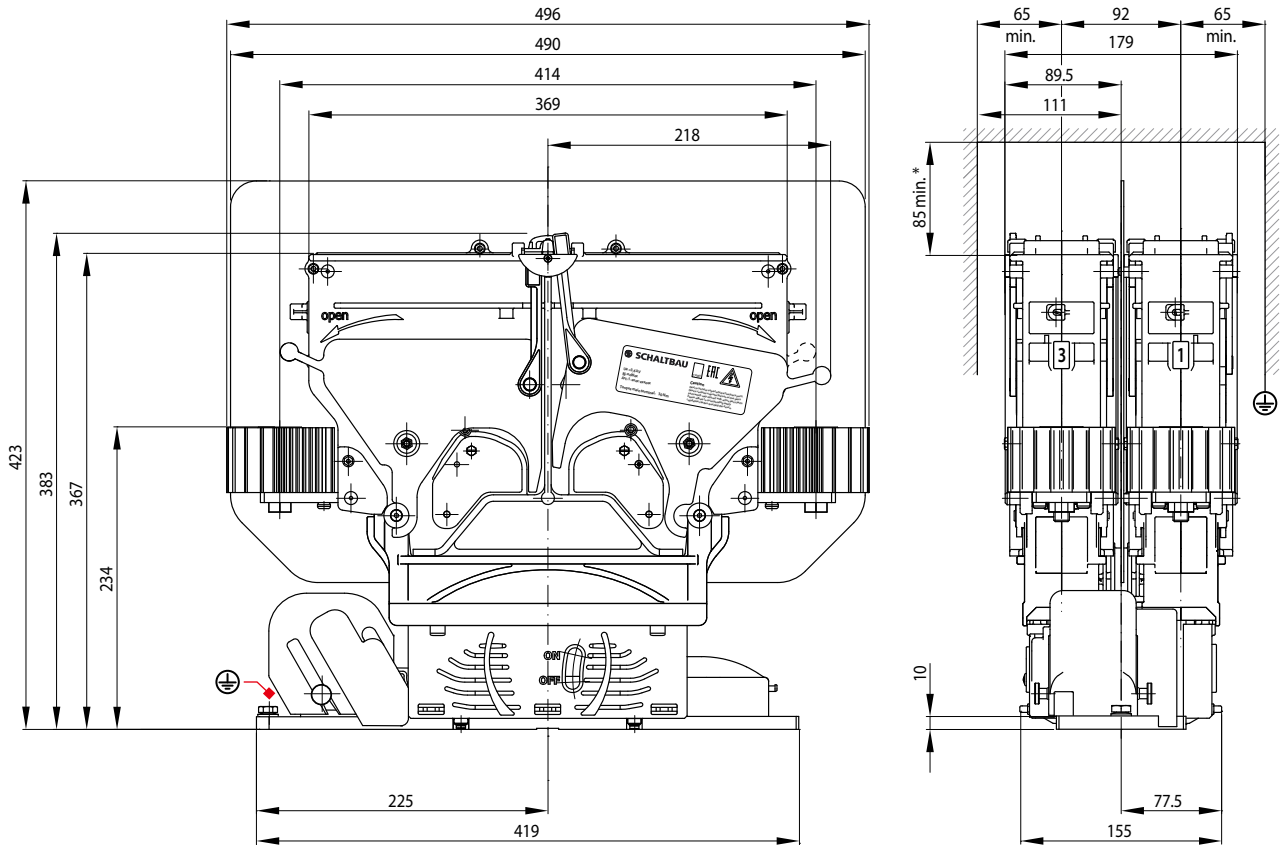

* Interrupting at maximum capacity could require larger clearance!
 Feel free to contact us, we will be happy to assist you with dimensioning.

Mounting holes

CT series

- Double pole NO contactor, CT1215/04, CT1230/04 series

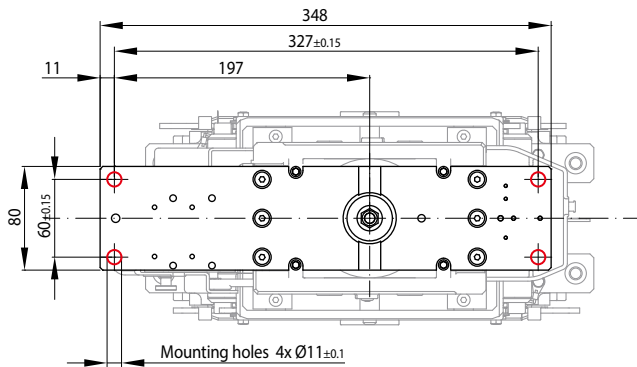

- Double pole NO contactor, CT1215/08, CT1230/08 series

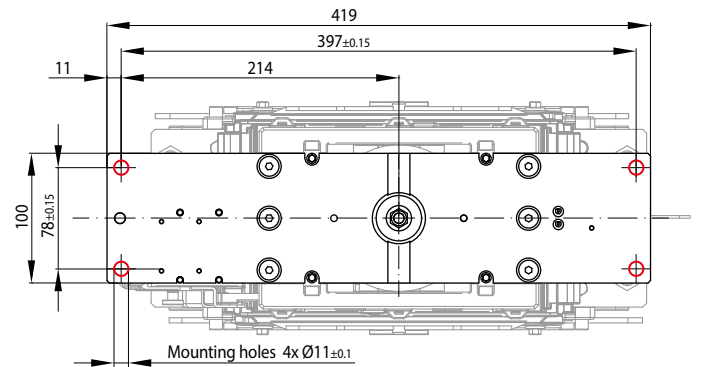

- Double pole NO contactor, CT1215/11, CT1230/11 series

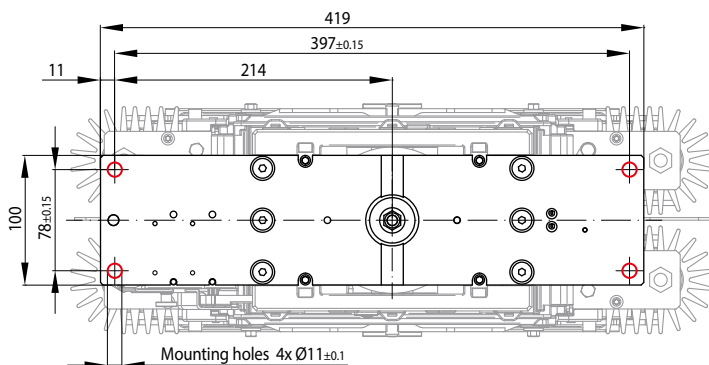

Mounting plate: bottom view

- The thickness of the mounting plate is:
- CT1215/04, CT1230/04: 8 mm
 - CT1215/08, CT1230/08: 10 mm
 - CT1215/11, CT1230/11: 10 mm

Mounting instructions

CT series

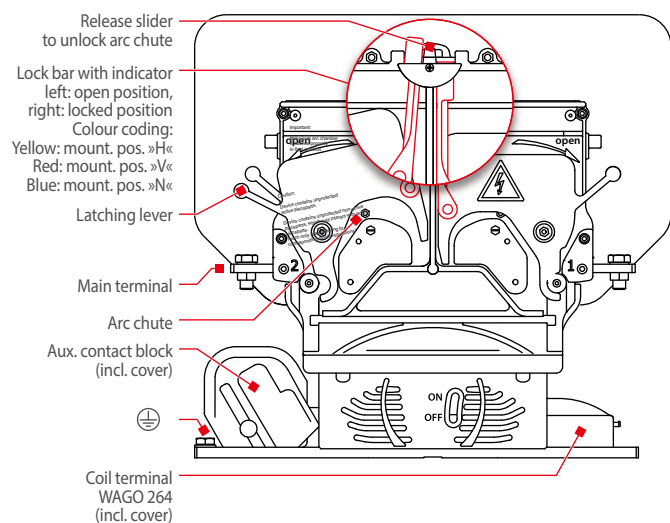

Dimensioning instructions

- Do you need some help? For selecting the contactor that suits your application best do not hesitate to ask our advice.
- For connection of the main contacts Schaltbau recommends the use of busbars with the following dimensioning:
 - Conv. thermal current $I_{th} = 400$ A: 60 x 5 mm
 - Conv. thermal current $I_{th} = 800$ A: 80 x 8 mm
- Observe clearance of live parts to arc chute! Refer to dimension drawings on page 4 and 5 for data.
- For high switching loads at $U_n \geq 3,000$ V DC a special design CT1130/08 ... 200 with adjusted blow-out coils is available.

Start up

Before initial start up make sure that:

- the arc chute is mounted properly and the lock bars are locked in position
- the protective covers are mounted properly
- the contactor is earthed (PE terminal on mounting plate)

Coil suppression

Coil suppression »T«, suppressor diode: Coil suppression for reducing surges when the coil is switched off is optimally attuned to the contactor's switching behaviour. Caution: Parallel connection with a simple diode will override the existing coil suppression.

Taking off the arc chute:

- Push both release sliders in the direction indicated by the arrow and hold them in this position.
- Move all four levers for unlocking the arc chute in the direction indicated by the arrow.
- The arc chute incorporating the stationary main contacts can now be lifted from the contactor.

Mounting the arc chute:

- Mount the arc chute onto the magnetic drive. Note: The arc chute has keys on one side to fit into slots on the corresponding side of the contactor. So you cannot mount it the wrong way round.
- Move all four levers for unlocking the arc chute into the original position.
- Check: The arc chute is locked properly, if all four lock bars click into place and cannot be opened without pushing the release slider.

Disassembly of protective covers:

- Protective cover auxiliary switches: Dismount arc chute first, then loosen knurled head screws and remove protective cover.
- Protective cover coil terminals: Unscrew cover and take it off.

Assembly of protective covers:

- Protective cover auxiliary switches: Position protective cover and screw in both knurled head screws. Then mount arc chute.
- Protective cover coil terminals: Introduce protective cover into the groove of the coil drive and locate in position. Then tighten screws.

Spare parts

CT series

Items	Spare part, description	Ordering code					
		CT1215/04	CT1230/04	CT1215/08	CT1230/08	CT1215/11	CT1230/11
1	Stationary contact, complete – order 2 per pole	MC CT1015/04	MC CT1030/04	MC CT1015/08	MC CT1030/08	MC CT1015/11	MC CT1030/11
1	Insulation plate	IP CT1015/04	IP CT1030/04	IP CT1015/08	IP CT1030/08	IP CT1015/08	IP CT1030/08
1	Contact bridge with mounted contact holder, mounting position »H«	CBH CT1015/04	CBH CT1030/04	CBH CT1015/08	CBH CT1030/08	CBH CT1015/08	CBH CT1030/08
1	Contact bridge with mounted contact holder, mounting position »V«	CBV CT1015/04	CBV CT1030/04	CBV CT1015/08	CBV CT1030/08	CBH CT1200/08	
1	Ceramic protection inserts – order 2 per pole	PI CT1030/04		PI CT1000/08			
1	Protective cover coil terminals	CC CT1030/04		CC CT1030/08			
1	Protective cover aux. switches	CA CT1030/04		CA CT1030/08			
1	Snap-action switch (SPDT)	S826 a L					
1	Contact block of 2x S870 (momentary switches a1, b0)	AS S870					



When ordering spare parts, please always give the exact series as well as the article number of the contactor, see type plate.

Subject to change

Mounting positions

CT series

The colour of the lock bars is an indication of the correct mounting position:

- H** **Horizontal:** Yellow lock bars ► Mounting position »H«
- V** **Vertical:** Red lock bars ► Mounting position »V«
- N** **Horizontal/vertical:** Blue lock bars ► Mounting position »H« or »V«

Horizontal mounting:

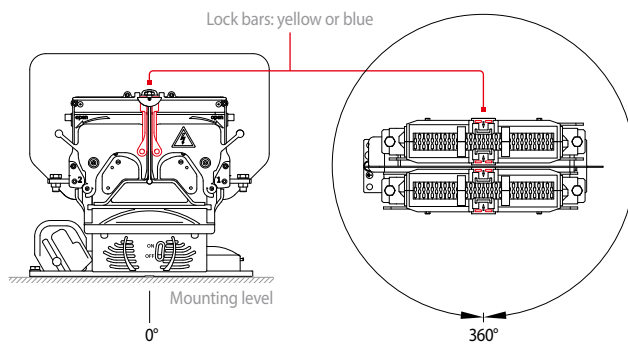

Vertical mounting:

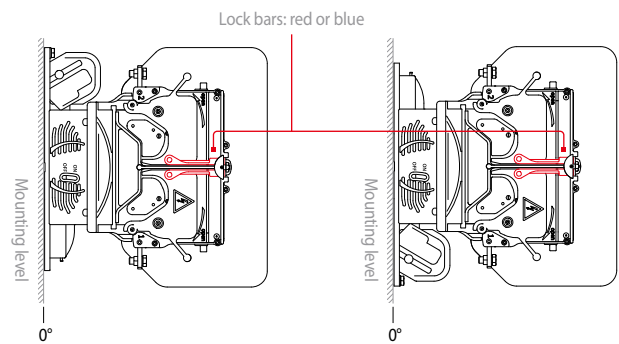

Mounting position:

Please observe the mounting position as shown on the nameplate.
 The permissible installation position can be recognized by the color of the lock bar.

Maintenance instructions



For detailed maintenance, safety and mounting instructions please refer to our operating manual
 ➔ [C20-C21-M.en!](#)

- CT series contactors are maintenance free with normal use.
- Make regular inspections once or twice a year. So when installing the contactor, make sure that there is enough space to remove and replace the arc chute with ease and that the main contacts become accessible for inspection.
- Frequent switching or switching under high load may lead to increased wear of the main contacts. In this case replacement of the main contacts may become necessary. For detailed information please refer to our manual.

Safety instructions

CT series

- The switching device meets the requirements of basic insulation. Make sure the plate onto which the drive of the contactor is mounted is earthed in a vibration resistant way.
- Do not use contactor without properly mounted arc chute.
- The contactor has unprotected live parts and carries a label that warns of the hazard. This caution must be observed and the label must not be removed in any way.
- The required clearance of live parts to ground and other parts of the contactor is to be observed as well as the safety regulations of the applicable standards.
- Switching at maximum breaking capacity might require larger clearance! Do not hesitate to ask our advice for dimensioning.
- Do not use contactor without protective covers (for coil terminals and auxiliary switches).
- Coil suppression for reducing surges when the coil is switched off is optimally attuned to the contactor's switching behaviour. The existing opening characteristic must not be negatively influenced by parallel connection with an external diode.
- Improper handling of the contactor, e.g. when hitting the floor with some impact, can result in breakage, visible cracks and deformation.



Defective parts must be replaced immediately!

Schaltbau GmbH

For detailed information on our products and services visit our website – or give us a call!

Schaltbau GmbH
Hollerithstrasse 5
81829 Munich
Germany



Phone +49 89 9 30 05-0
Fax +49 89 9 30 05-350
Internet www.schaltbau.com
e-Mail contact@schaltbau.de

with compliments:



The production facilities of Schaltbau GmbH have been IRIS certified since 2008.



Certified to DIN EN ISO 14001 since 2002. For the most recent certificate visit our website.



Certified to DIN EN ISO 9001 since 1994. For the most recent certificate visit our website.

Electrical Components and Systems for Railway Engineering and Industrial Applications

Connectors

- Connectors manufactured to industry standards
- Connectors to suit the special requirements of communications engineering (MIL connectors)
- Charging connectors for battery-powered machines and systems
- Connectors for railway engineering, including UIC connectors
- Special connectors to suit customer requirements

Snap-action switches

- Snap-action switches with positive opening operation
- Snap-action switches with self-cleaning contacts
- Snap-action switch made of robust polyetherimide (PEI)
- Snap-action switch with two galvanically isolated contact bridges
- Special switches to suit customer requirements

Contactors Emergency disconnect switches

- Single and multi-pole DC contactors
- High-voltage AC/DC contactors
- Contactors for battery powered vehicles and power supplies
- Contactors for railway applications
- Terminal bolts and fuse holders
- DC emergency disconnect switches
- Special contactors to suit customer requirements

Electrics for rolling stock

- Equipment for driver's cab
- Equipment for passenger use
- High-voltage switchgear
- High-voltage heaters
- High-voltage roof equipment
- Equipment for electric brakes
- Design and engineering of train electrics to customer requirements