

3

Contactors

CH1130/02 Series

Single pole
high-voltage contactor
up to 3 kV

Catalogue C170.en

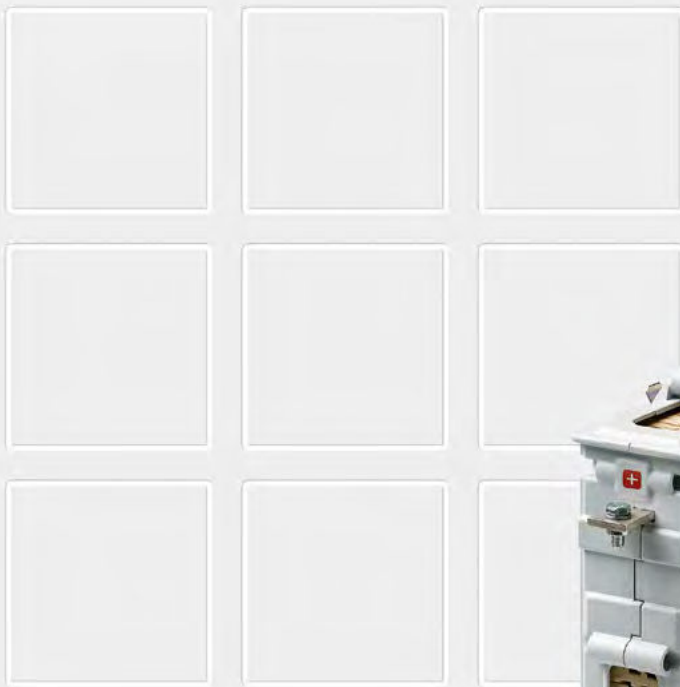

More information at:
schaltbau-gmbh.com

CH1130/02 Single pole high-voltage contactor for DC and AC

CH Series – Compact HV contactor in new design

Schaltbau has introduced an update of its CH Series high-voltage contactors which have proven their worth in industrial and railway applications for decades. Its completely modernized design is comparable to the one of the most successful CT series. The new CH1130/02 also uses permanent magnets and ceramic elements for quenching the

electric arc, thus ensuring optimal functionality and reliability of the contactor.

The customer is now offered a new version for 3 kV DC and AC with thermal current I_{th} of up to 250 A!

Features

- Suitable for AC and DC, semi-bidirectional (limited switching capability when current direction reversed)
- Compact, rugged design
- Double-break contacts
- Use of ceramic elements for extinguishing the arc
- CH1130/02 replacing the 4 existing CH contactor series
- Easy visual inspection of state of contacts (no tools)
- Tested to railway standard IEC 60077

Applications

The high-voltage switching device is especially suited for use as pre-charging and switch-on contactor in power supplies and as control contactor for resistor banks in heating and air conditioning equipment of rolling stock.

Series CH

Ordering code

Series CH

CH1130/02 Series Single pole high-voltage contactor

Example: CH1130/02 110ET-00			
Series	_____		Aux. switch
CH11	Single pole		00
Nominal voltage	_____	2x S826 Ag, M3 screws	01
30	$U_n = 3.000\text{ V}$	2x S926 Au, flat tabs 6.3 x 0.8	02
Conv. thermal current	_____	2x S926 Au, flat tabs 6.3 x 0.8	03
02	$I_{th} = 250\text{ A}$	2x S826 Au, M3 screws	
Coil voltage	_____		Coil suppression
24 / 36 / 72 / 110 V DC			T
			Coil tolerance
		Suppressor diode	E
			-30 % ... +25 % U_{sn}

Note:

Presented in this catalogue are only stock items which can be supplied in short delivery time. For some variants minimum quantities apply. Please do not hesitate to ask for the conditions.

Special variants:

If you need a special variant of the contactor, please do not hesitate to contact us. Maybe the type of contactor you are looking for is among our many special designs. If not, we can also supply customized designs. In this case, however, minimum order quantities apply.

Standards

Series CH

- IEC 60077-1:2002 Railway applications – Electric equipment for rolling stock – Part 1: General service conditions and general rules.
- IEC 60077-2:2002 Railway applications – Electric equipment for rolling stock – Part 2: Electrotechnical components; General rules
- EN 61373:2010 Railway applications – Rolling stock equipment – Shock and vibration tests

• **Dimensions**

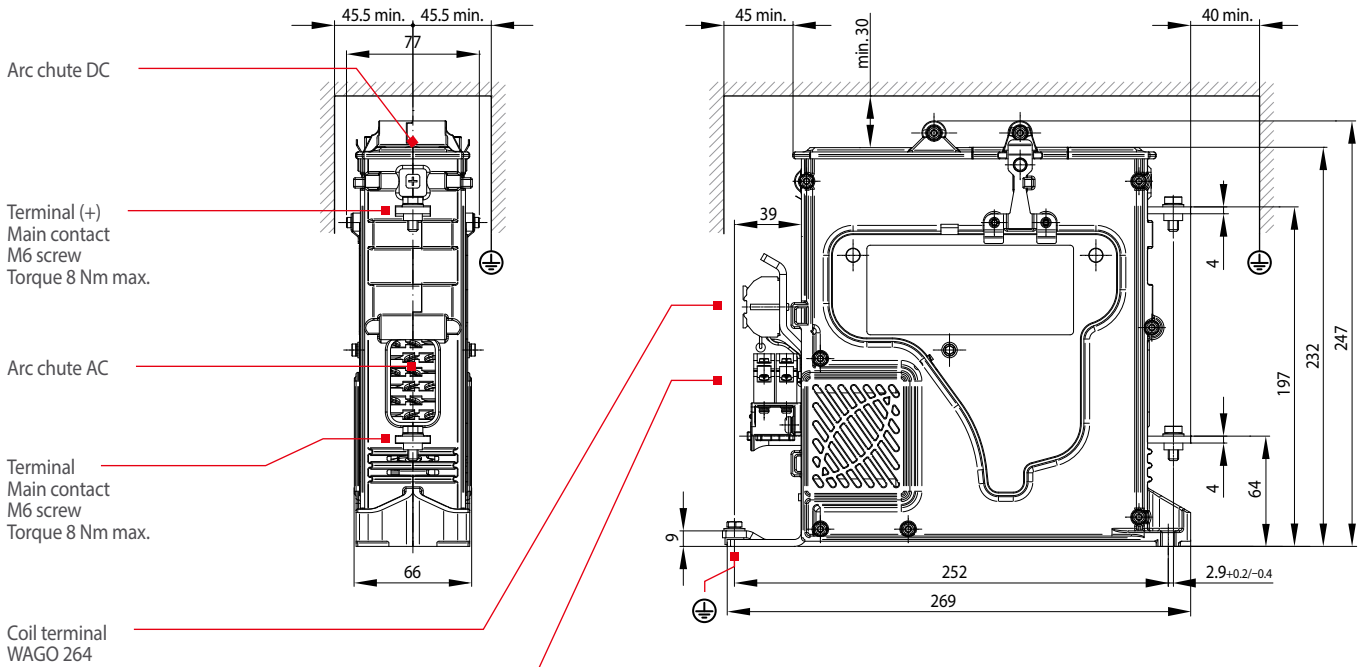

Visual inspection of main contacts
 Push both clips apart and pull out segment of arc chute positioned in the inspection area to make room for a visual inspection of the main contacts.

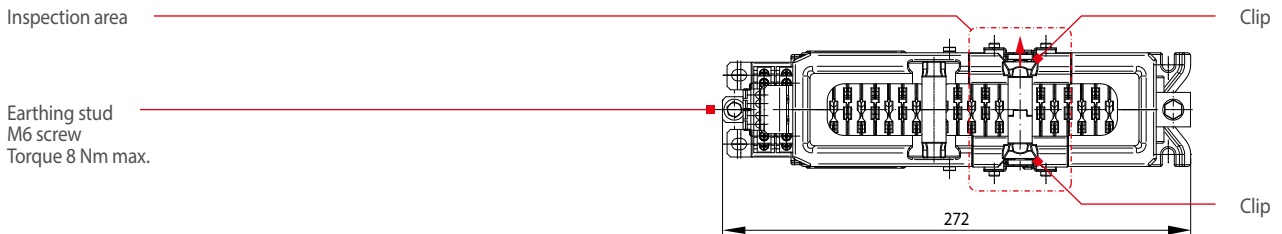

• **Circuit diagram**

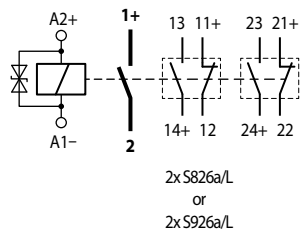

Mounting

Series CH

• Orientations

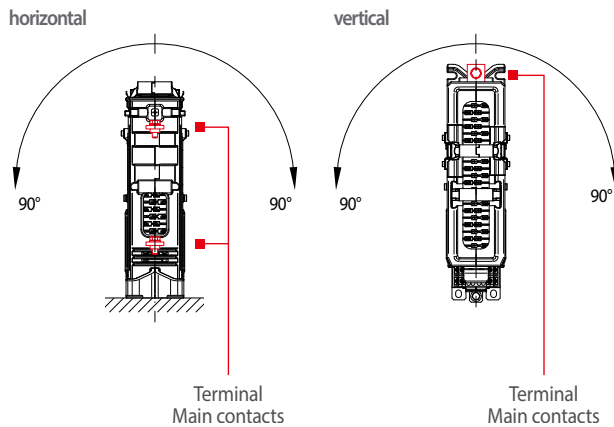

• Mounting holes

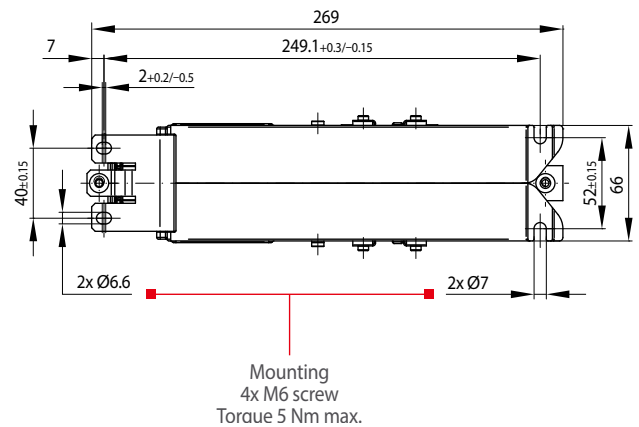

Maintenance and safety instructions

Series CH

Maintenance:

- CH1130/02 Series contactors are maintenance free with normal use.
- Make regular inspections once or twice a year. So when installing the contactor, make sure that there is enough space to take out and re-assemble the segment of the arc chute with ease, so that the main contacts become accessible for inspection.
- Visual inspection of main contacts:
For visual inspection of the main contacts there is an opening in the arc chute. Push both clips apart and pull out the segment of the arc chute that is positioned in the inspection opening to make room for a visual inspection of the main contacts. Re-assembly is done in reverse order. Make sure not to replace the segment turned by 180° and by applying force.
- Frequent switching or switching under high load may lead to increased wear of the main contacts. In this case replacement of the main contacts may become necessary.

Safety instructions:

- The device must be used according to the intended purpose as specified in the technical documentation. You are obliged to observe all specifications depending on operating temperature, degree of pollution etc. that are relevant to your application.
- Without further safety measures the CS Series contactors are not suited for use in potentially explosive atmospheres.
- In case of malfunction of the device or uncertainties stop using it any longer and contact the manufacturer instantly.
- Tampering with the device can seriously affect the safety of people and equipment. This is not permitted and leads to an exclusion of liability and warranty.
- Coil suppression for reducing surges when the coil is switched off is optimally attuned to the contactor's switching behaviour. The existing opening characteristic must not be negatively influenced by parallel connection with an external diode.
- Contactors running permanently may heat up. So make sure that the contactor has sufficiently cooled down before you start any inspection or maintenance work.
- When installing contactors with magnetic blowout make sure to do it in such a way that no magnetizable parts can be attracted by the permanent magnets that are also capable of destroying all data of swipe cards.
- Strong electromagnetic induction caused when switching off can influence other components installed near the contactor.
- Improper handling of the contactor, e.g. when hitting the floor with some impact, can result in breakage, visible cracks and deformation.



For detailed maintenance, safety and mounting instructions refer to our operating manual
 ➔ [C170-M.en!](#)



Defective parts must be replaced immediately!

Specifications

Series CH

Series	CH1130/02
Type of voltage	DC (semi bidirectional ^{*1}), AC (f < 60 Hz)
Contact configuration	1x SPST-NO
Nominal voltage U_n	3,000 V
Rated operating voltage U_e	3,600 V
Rated insulation voltage U_{Nm}	4,800 V
Rated impulse withstand voltage U_{Ni}	25 kV
Pollution degree / Overvoltage category	PD3 / OV3
Switching surges $U_e = 3,600$ V	<14.9 kV / <22 kV (at <10 A and T = 30 ms only)
Conventional thermal current I_{th} at wire gauge	250 A 120 mm ² (236,827 Mils) min.
Component category (IEC 60077-2)	A2
Short-circuit making capacity	1.6 kA (new contacts) / 2 kA (used contacts)
Breaking capacity (T2 = 15 ms)	
DC, $U_e = 1,200$ V	300 A
DC, $U_e = 1,800$ V	200 A
DC, $U_e = 3,600$ V	50 A
Breaking capacity (T2 = 1 ms)	
DC, $U_e = 1,200$ V	550 A
DC, $U_e = 1,800$ V	400 A
DC, $U_e = 3,600$ V	90 A
Breaking capacity, reverse current direction (T2 < 1 ms)	
DC, $U_e = 900$ V	110 A
DC, $U_e = 1,800$ V	30 A
Breaking capacity ($\cos\phi = 1$)	
AC, $U_e = 900$ V (f = 16 $\frac{2}{3}$)	700 A
AC, $U_e = 1,800$ V (f = 16 $\frac{2}{3}$)	200 A
Breaking capacity ($\cos\phi = 0.8$)	
AC, $U_e = 900$ V (f = 16 $\frac{2}{3}$)	400 A
AC, $U_e = 1,800$ V (f = 16 $\frac{2}{3}$)	120 A
Breaking capacity ($\cos\phi = 1$)	
AC, $U_e = 900$ V (f = 50 Hz)	420 A
AC, $U_e = 1,800$ V (f = 50 Hz)	100 A
Rated short-time withstand current I_{cw} (T < 100 ms)	3 kA
Critical current range	None ^{*2}
Main contacts	
Contact material	AgSnO ₂
Terminal	M6 screw
Torque	8 Nm max.
Auxiliary contacts	
Configuration	2x S826 or 2x S926, see also Catalogue D26.en
Contact material	Silver or Gold
Breaking capacity (T = 5 ms) ^{*3}	DC13 (110 V: 0.2 A; 24 V: 2 A)
Terminal	M3 screws or flat tabs 6.3 x 0.8 mm
Coil (coil suppression »T«, suppressor diode)	
Pollution degree / Overvoltage category	PD3 / OV2
Coil voltage U_s	24 / 36 / 72 / 110 V DC
Coil tolerance	0,7 ... 1,25 U_s
Power consumption at U_s and $T_a = 20$ °C	Cold coil: 37.5 W / Warm coil: 26.5 W
Pull-in voltage, typ. at $T_a = 20$ °C	0.6 x U_s
Pull-in time, typ. at $T_a = 20$ °C	< 60 ms
Drop-out voltage, typ. at $T_a = 20$ °C	0.1 ... 0.4 x U_s
Drop-out time, typ. at $T_a = 20$ °C	< 30 ms
Coil suppression	Suppressor diode
Coil terminal	Cage clamp
IP rating (IEC 60529 IP code)	IP00
Mechanical endurance	> 2 million operating cycles
Vibration / Shock (IEC 61373)	Category 1, Class B
Mounting orientation	horizontal / vertical, terminal studs pointing upwards
Ambient conditions	
Working temperature / Storage temperature	-50 °C ... +70 °C ^{*4} / -50 °C ... +85 °C
Altitude	< 2,000 m above sea level
Humidity (IEC 50125-1)	< 75 % on an annual average
Weight	< 6 kg

^{*1} Limited breaking capacity when current direction reversed

^{*2} At high inductive loads < 10 A (T > 20 ms)

^{*3} Valid for silver contacts, data for gold contacts on request

^{*4} Working temperature -50 °C with S926 series aux. contacts only, otherwise -40 °C

Schaltbau GmbH

For detailed information on our products and services visit our website – or give us a call!

Schaltbau GmbH
Hollerithstrasse 5
81829 Munich
Germany



Phone +49 89 9 30 05-0
Fax +49 89 9 30 05-350
Internet www.schaltbau-gmbh.com
e-Mail contact@schaltbau.de

with compliments:



The production facilities of Schaltbau GmbH have been IRIS certified since 2008.



Certified to DIN EN ISO 14001 since 2002. For the most recent certificate visit our website.



Certified to DIN EN ISO 9001 since 1994. For the most recent certificate visit our website.

Electrical Components and Systems for Railway Engineering and Industrial Applications

Connectors

- Connectors manufactured to industry standards
- Connectors to suit the special requirements of communications engineering (MIL connectors)
- Charging connectors for battery-powered machines and systems
- Connectors for railway engineering, including UIC connectors
- Special connectors to suit customer requirements

Snap-action switches

- Snap-action switches with positive opening operation
- Snap-action switches with self-cleaning contacts
- Enabling switches
- Special switches to suit customer requirements

Contactors

- Single and multi-pole DC contactors
- High-voltage AC/DC contactors
- Contactors for battery powered vehicles and power supplies
- Contactors for railway applications
- Terminal bolts and fuse holders
- DC emergency disconnect switches
- Special contactors to suit customer requirements

Electrics for rolling stock

- Equipment for driver's cab
- Equipment for passenger use
- High-voltage switchgear
- High-voltage heaters
- High-voltage roof equipment
- Equipment for electric brakes
- Design and engineering of train electrics to customer requirements

We reserve the right to make technical alterations without prior notice.

For updated product information visit www.schaltbau.com.
Issued 11-2022