

3

Contactors

C100/80, C100/120
C100/200, C100/320

Single pole
DC NO contactors
for industrial trucks

Catalogue [B70.en](#)



More information
schaltbau.com

DC contactors for battery voltages, C100 series

Our C100 Series contactors are the easy and economical solution for switching DC currents of 60 A up to 320 A as well as battery voltages of up to 80 V. The contactors are equipped with DC coils featuring coil tolerances as required for traction batteries of industrial trucks and other battery-powered vehicles.

C100 Series contactors are single pole NO DC contactors with magnetic blowout designed for use as main or auxiliary contactors. The magnetic blow-out they feature ensures a long service life with respect to electrical endurance.

Only stock items are dealt with in this catalogue.

Features

- Compact, rugged design
- Types of 4 different sizes
- Double-break cadmium-free contacts
- Extra wide coil tolerance
- Applicable standards: EN1175-1, IEC 60947-1, IEC 60947-4-1
- Approval: 

Applications

- Main contactor for materials handling vehicles
- Main contactor for all kind of battery-powered vehicles
- Auxiliary contactor for steering and control functions, and the like

Series C100



C100/80 and C100/120 Series contactors



C100/200 and C100/320 Series contactors

Ordering code

Example: **C100/80 24RX-V1**

Series	C100	single pole DC NO contactor
Operating current	80	80 A DC
	120	120 A DC
	200	200 A DC
	320	320 A DC
Coil voltage	24 / 48 V DC	
Coil tolerance	R	-30 % ... +10 %
Diode coil suppression	X	none
Auxiliary contact, type of	V	micro switch, SPDT
Auxiliary contact, number of	1	one auxiliary switch

Standard items

Series C100

Presented in this catalogue are only stock items which can be supplied in short delivery time.

The following options are also available:

- SPDT
- Double pole SPST NO
- Mounting brackets
- Omega-shape brackets (only C100/120)
- Large contacts
- Closed contact housings
- Coils for other voltages
- Coils for 70% duty with stronger spring

Special variant

If you need a special variant of the contactor, please do not hesitate to contact us. Maybe, the type of contactor you are looking for is among our many **special designs**. If not, we can also supply **customized designs**. In this case, however, minimum order quantities apply.

Specifications

Series C100

Series	C100/80	C100/120	C100/200	C100/320
Kind of voltage	DC			
Main contacts, number of, configuration	1x SPST NO			
Nominal voltage U_n	80 V			
Rated insulation voltage U_i	150 V			
Rated impulse withstand voltage U_{imp}	2.5 kV			
Pollution degree Overvoltage category	PD3 OV3			
Rated operational current I_e (70% duty cycle, repetition time: 60 s)	80 A	120 A	200 A	320 A
Conventional free air thermal current I_{th}	60 A	100 A	150 A	250 A
Making capacity, resistive load, $T = 1$ msec	300 A	600 A	1,000 A	1,600 A
Breaking capacity, $T < 1$ msec	NO 80 V DC: 250 A	80 V DC: 300 A	80 V DC: 500 A	80 V DC: 1,300 A
Rated short-time withstand current I_{cw}	400 A / 100 msec	800 A / 100 msec	1,500 A / 100 msec	2,000 A / 100 msec
Switch-off, no reversing	only in one direction			
Main contacts Contact material Terminals / torque	NO: AgSnO ₂ M6 / 5 Nm max.	NO: AgSnO ₂ M8 / 7 Nm max.	NO: AgSnO ₂ M8 / 7 Nm max.	NO: AgSnO ₂ M10 / 10 Nm max.
Auxiliary contact Mirror contact IEC 60947-4-1, Annex F Number of / configuration Switching capacity, $T = 0$ ms Terminals, Flat tabs	✓ 1x SPDT 2.5 A at 24 V DC; 1.0 A at 48 V DC; 0.5 A at 80 V DC 2.0 x 0.5 mm		✓ 1x SPDT 2.5 A at 24 V DC; 1.0 A at 48 V DC; 0.5 A at 80 V DC 6.3 x 0.8 mm	
Magnetic drive Coil voltage U_s Coil tolerance Coil power dissipation at U_s and $T_a = 20$ °C cold / warm coil Coil suppression Coil terminals, Flat tabs	24 / 48 V DC -30 % ... +10 % U_s < 6.5 W / < 5.5 W --- 6.3 x 0.8 mm	24 / 48 V DC -30 % ... +10 % U_s < 14 W / < 11.5 W --- 6.3 x 0.8 mm	24 / 48 V DC -30 % ... +10 % U_s < 19 W / < 16 W --- 6.3 x 0.8 mm	24 / 48 V DC -30 % ... +10 % U_s < 24 W / < 20 W --- 6.3 x 0.8 mm
Degree of protection	IP00			
Mechanical life cycles	> 3 x 10 ⁶			
Electrical life	> 100.000 cycles (U_n , I_{th} , $T < 1$ msec, cycle ≤ 6 /min)			
Vibration / shock IEC 60068-2-6, IEC 60068-2-27	6 g (10 ... 500 Hz) / 30 g (11 msec, half sinus)			
Mounting position	horizontal or vertical (contact studs must point upwards)			
Temperature Ambient temperature T_a Storage temperature T_L	-25 °C ... +40 °C -40 °C ... +85 °C			
Weight	< 250 g	< 450 g	< 800 g	< 1.500 g

C100/80 Single pole NO contactor 80 A DC

C100/80 Series contactors are designed for currents of up to **80 A** DC and battery voltages of up to **80 V**.

The C100/80 is a single pole NO contactor with magnetic blowout suitable for use as main or auxiliary contactor.

The contactors are fitted with DC coils featuring an extra wide coil tolerance as required for traction batteries of industrial trucks and other battery-powered vehicles.

See data sheet for detailed specifications on page 2.

Dimension and Circuit diagrams

Dimension diagram

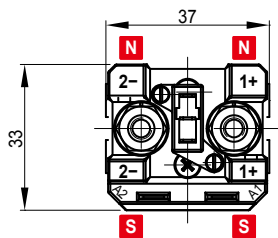
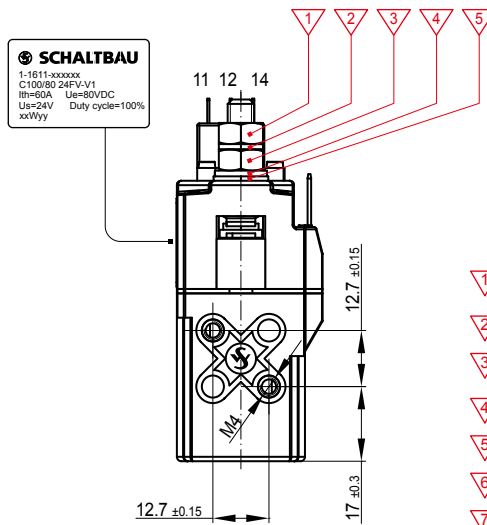
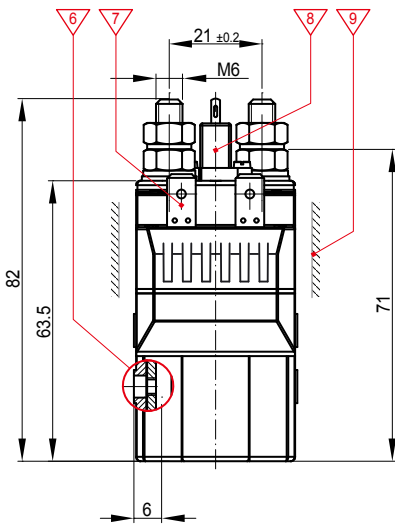

- 1 Nut M6 DIN EN ISO 4032; steel, white zinc plated
Permissible tightening torque 4 ... 5 Nm
- 2 Retaining washer 6
- 3 Nut M6 DIN EN ISO 4032; brass, without surface-coating.
Permissible tightening torque 2 Nm.
- 4 Spring washer 6
- 5 Washer 6, non-standard
- 6 Maximum length of engagement 2.5 mm
- 7 Coil terminal: Flat quick-connect 6.3x0.8 DIN46244
- 8 Auxiliary contact: Flat quick-connect termination 2x0.5
- 9 At arc exit the minimum clearance must be > 50mm
(in all other areas a minimum clearance of 5 mm must be maintained to all sides)

Circuit diagram

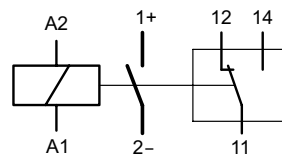

Mounting accessories

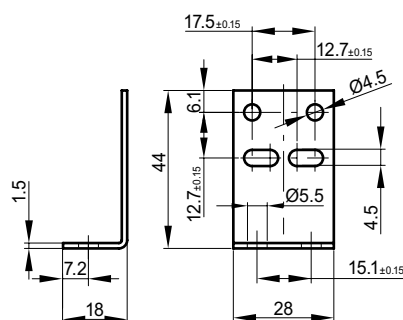
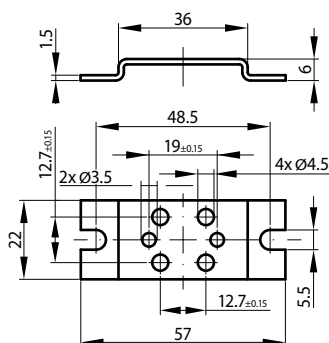

Note:
Please observe 9 when using mounting brackets!

Horizontal mounting brackets
Ordering code **MB-H S1 mounting brackets**

Vertical mounting brackets
Ordering code **MB-V S1 mounting brackets**

C100/120 Single pole NO contactor 120 A DC

C100/120 Series contactors are designed for currents of up to **120 A DC** and battery voltages of up to **80 V**.

The C100/120 is a single pole NO contactor with magnetic blowout suitable for use as main or auxiliary contactor.

The contactors are fitted with DC coils featuring an extra wide coil tolerance as required for traction batteries of industrial trucks and other battery-powered vehicles.

See data sheet for detailed specifications on page 2.

Dimension and Circuit diagrams

Dimension diagram

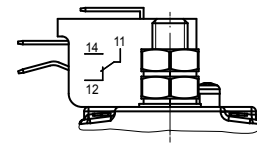
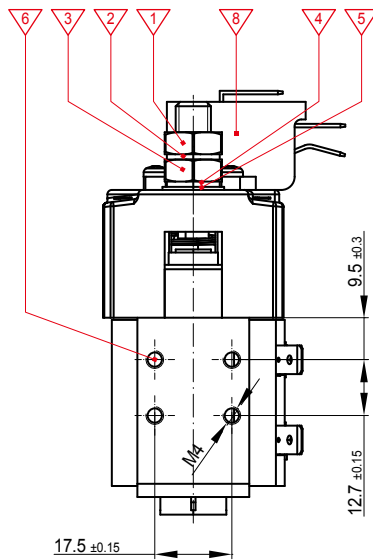
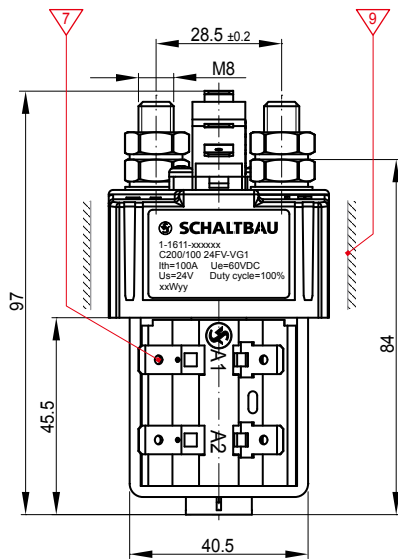

- 1 Nut M8 DIN EN ISO 4032; steel, white zinc plated
Permissible tightening torque 6 ... 7 Nm
- 2 Retaining washer 8
- 3 Nut M8 DIN EN ISO 4032; brass, without surface-coating.
Permissible tightening torque 3 Nm.
- 4 Spring washer 8
- 5 Washer 8, non-standard
- 6 Maximum length of engagement 2.5 mm
- 7 Coil terminal: Flat quick-connect 6.3x0.8 DIN46244
- 8 Auxiliary contact: Flat quick-connect termination 6.3x0.8
- 9 At arc exit the minimum clearance must be > 60mm
(in all other areas a minimum clearance of 5 mm must be maintained to all sides)

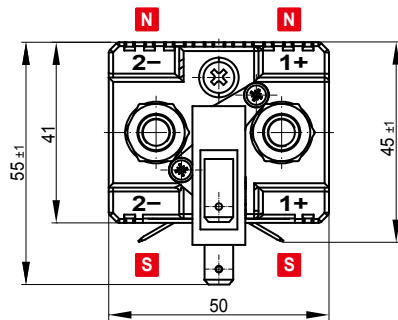

Circuit diagram

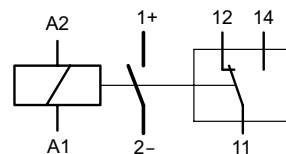

Mounting accessories

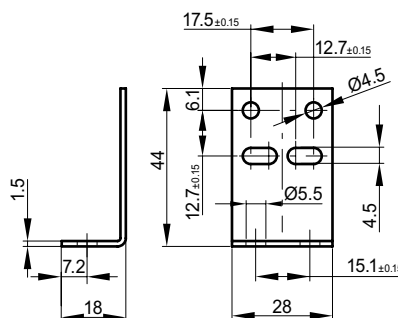
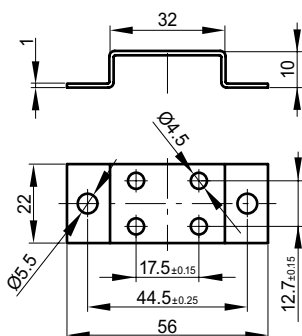

Note:
Please observe **9** when using mounting brackets!

Horizontal mounting brackets
Ordering code **MB-H S2 mounting brackets**

Vertical mounting brackets
Ordering code **MB-V S1 mounting brackets**

Subject to change / Dimensions in mm

C100/200 Single pole NO contactor 200 A DC

C100/200 Series contactors are designed for currents of up to **200 A DC** and battery voltages of up to **80 V**.

The C100/200 is a single pole NO contactor with magnetic blowout suitable for use as main or auxiliary contactor.

The contactors are fitted with DC coils featuring an extra wide coil tolerance as required for traction batteries of industrial trucks and other battery-powered vehicles.

See data sheet for detailed specifications on page 2.

Dimension and Circuit diagrams

Dimension diagram

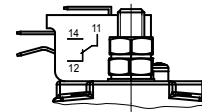
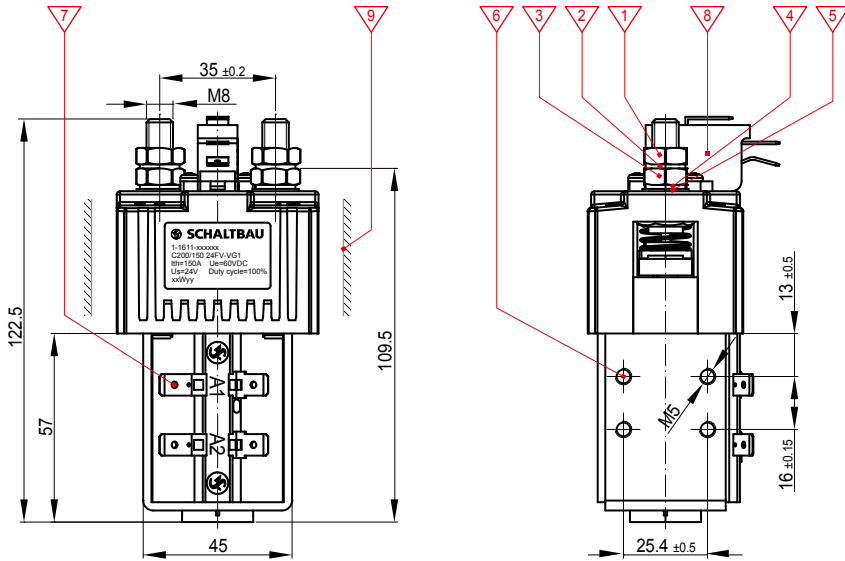

- ▽ 1 Nut M8 DIN EN ISO 4032; steel, white zinc plated
Permissible tightening torque 6 ... 7 Nm
- ▽ 2 Retaining washer 8
- ▽ 3 Nut M8 DIN EN ISO 4032; brass, without surface-coating.
Permissible tightening torque 3 Nm.
- ▽ 4 Spring washer 8
- ▽ 5 Washer 8, non-standard
- ▽ 6 Maximum length of engagement 3.0 mm
- ▽ 7 Coil terminal: Flat quick-connect 6.3x0.8 DIN46244
- ▽ 8 Auxiliary contact: Flat quick-connect termination 6.3x0.8
- ▽ 9 At arc exit the minimum clearance must be > 70mm
(in all other areas a minimum clearance of 5 mm must be maintained to all sides)

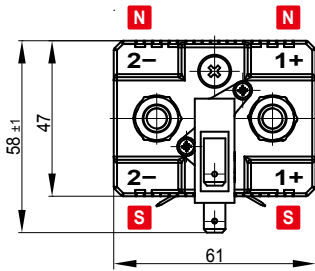

Circuit diagram

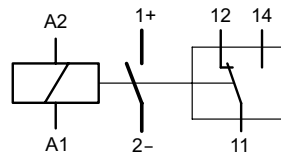

Mounting accessories

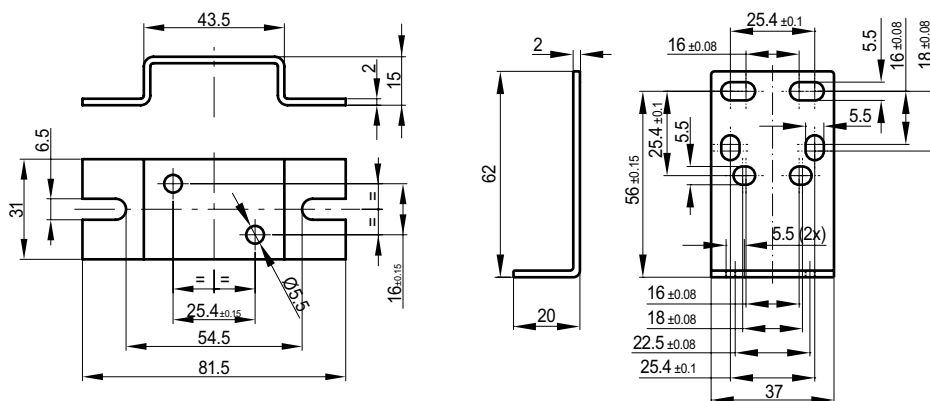

Note:
Please observe ▽ 9 when using mounting brackets!

Horizontal mounting brackets
Ordering code **MB-H S3 mounting brackets**

Vertical mounting brackets
Ordering code **MB-V S2 mounting brackets**

C100/320 Single pole NO contactor 320 A DC

C100/320 Series contactors are designed for currents of up to **320 A DC** and battery voltages of up to **80 V**.

The C100/320 is a single pole NO contactor with magnetic blowout suitable for use as main or auxiliary contactor.

The contactors are fitted with DC coils featuring an extra wide coil tolerance as required for traction batteries of industrial trucks and other battery-powered vehicles.

See data sheet for detailed specifications on page 2.

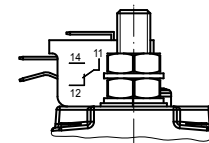
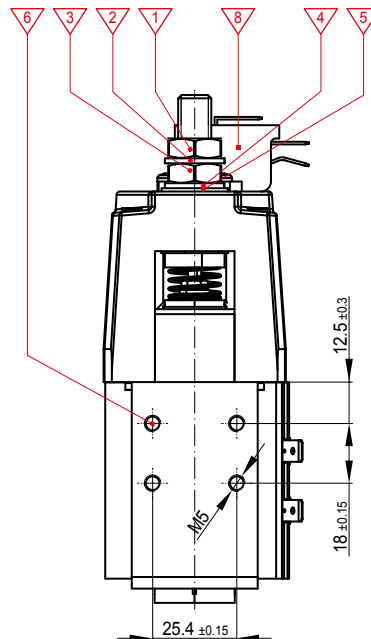
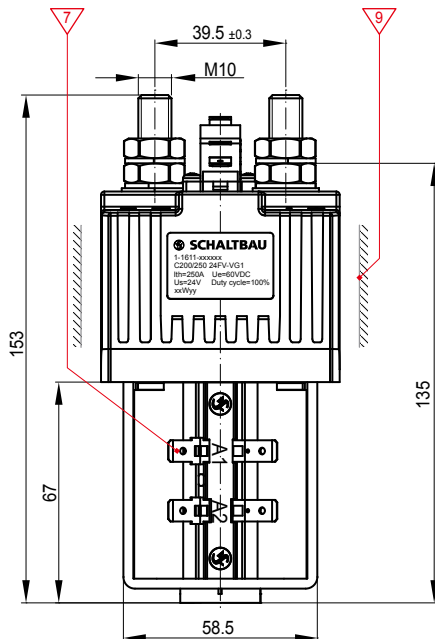
Dimension and Circuit diagrams
Dimension diagram

- 1 Nut M10 DIN EN ISO 4032; steel, white zinc plated
Permissible tightening torque 6 ... 7 Nm
- 2 Retaining washer 10
- 3 Nut M10 DIN EN ISO 4032; brass, without surface-coating. Permissible tightening torque 3 Nm.
- 4 Spring washer 10
- 5 Washer 10, non-standard
- 6 Maximum length of engagement 3.5 mm
- 7 Coil terminal: Flat quick-connect 6.3x0.8 DIN46244
- 8 Auxiliary contact: Flat quick-connect termination 6.3x0.8
- 9 At arc exit the minimum clearance must be > 100mm
(in all other areas a minimum clearance of 5 mm must be maintained to all sides)

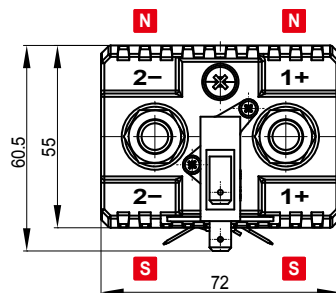
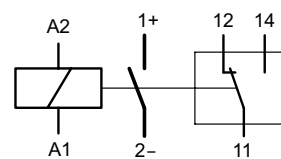
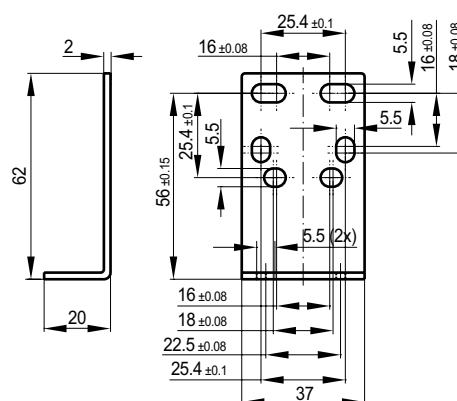
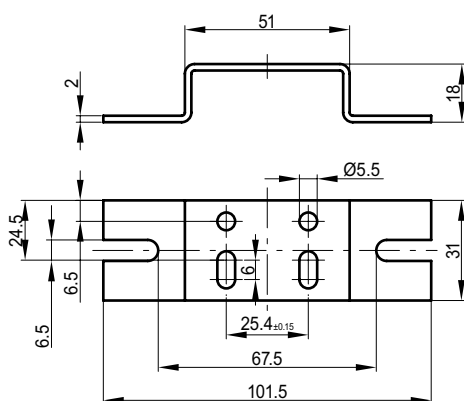
Circuit diagram

Mounting accessories

Note:

Please observe 9 when using mounting brackets!

Horizontal mounting brackets

Ordering code **MB-H S4 mounting brackets**

Vertical mounting brackets

Ordering code **MB-V S2 mounting brackets**

Schaltbau GmbH

For detailed information on our products and services visit our website – or give us a call!

Schaltbau GmbH
Hollerithstrasse 5
81829 Munich
Germany



Phone +49 89 9 30 05-0
Fax +49 89 9 30 05-350
Internet www.schaltbau.com
e-Mail contact@schaltbau.de

with compliments:



Schaltbau GmbH manufactures in compliance with RoHS.



The production facilities of Schaltbau GmbH have been IRIS certified since 2008.



Certified to DIN EN ISO 14001 since 2002. For the most recent certificate visit our website.



Certified to DIN EN ISO 9001 since 1994. For the most recent certificate visit our website.

Electrical Components and Systems for Railway Engineering and Industrial Applications

Connectors

- Connectors manufactured to industry standards
- Connectors to suit the special requirements of communications engineering (MIL connectors)
- Charging connectors for battery-powered machines and systems
- Connectors for railway engineering, including UIC connectors
- Special connectors to suit customer requirements

Snap-action switches

- Snap-action switches with positive opening operation
- Snap-action switches with self-cleaning contacts
- Enabling switches
- Special switches to suit customer requirements

Contactors

- Single and multi-pole DC contactors
- High-voltage AC/DC contactors
- Contactors for battery powered vehicles and power supplies
- Contactors for railway applications
- Terminal bolts and fuse holders
- DC emergency disconnect switches
- Special contactors to suit customer requirements

Electrics for rolling stock

- Equipment for driver's cab
- Equipment for passenger use
- High-voltage switchgear
- High-voltage heaters
- High-voltage roof equipment
- Equipment for electric brakes
- Design and engineering of train electrics to customer requirements