

3

Contactors

C295 series

Double pole
NO contactors

Installation and maintenance
instructions

Manual B295-M.en

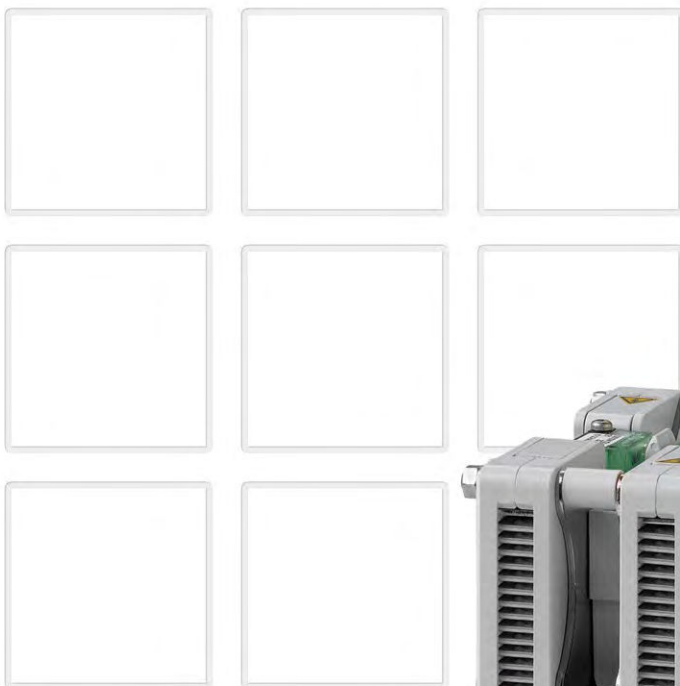

Document Revision History

Date	Rev. Level	Description	Pages
2020-05-13	1.0	First release	all

Content

1. Important basic information	4
1.1 Legal notes	4
1.2 Conventions for this manual.....	4
2. General and security information	4
2.1 Observing the instructions.....	4
2.2 User obligations.....	5
2.3 Intended use	5
2.4 Ambient conditions.....	5
3. Dangers and security measures.....	6
3.1 Electrical dangers.....	6
3.2 Other dangers	6
3.3 Measures for avoiding damages and malfunctions	7
4. Product information.....	8
4.1 Double pole NO contactor, C295 Series.....	8
4.2 Features	8
4.3 Applications	8
4.4 Technical information and material specification	8
4.5 Overview	9
5. Storage.....	10
6. Unpacking.....	10
6.1 Unpack the device	10
6.2 Check parts for transport damage.....	10
7. Installation	11
7.1 Mechanical installation	11
7.1.1 Dimensions and further technical specifications	11
7.1.2 Preliminaries	11
7.1.3 Correct mounting positions	11
7.1.4 Required minimum clearance	12
7.1.5 Ventilation requirements	12
7.1.6 Safety.....	12
7.1.7 Required tools	12
7.1.8 Install the contactor	12

7.2	Electrical installation.....	13
7.2.1	Electrical data and further technical specifications.....	13
7.2.2	Preliminaries	13
7.2.3	Safety	13
7.2.4	Required tools	14
7.2.5	Connect the auxiliary contacts.....	14
7.2.6	Connect the coil terminals.....	15
7.2.7	Connect the main contacts	15
	Main contact connection with cables	15
	Main contact connection with busbars	16
7.3	Checks	17
8.	Maintenance	18
8.1	Safety	18
8.2	Preventive maintenance.....	18
8.2.1	Intervals for regular checks.....	18
8.2.2	Regular check activities	19
8.3	Corrective maintenance	20
8.3.1	Replace the auxiliary contacts.....	20
	Required spare parts.....	20
	Required tools	20
	Disassembly	20
	Assembly	21
8.3.2	Check the main contacts.....	21
	Preliminaries	21
	Required tools	21
	Check the main contacts for wear and tear.....	21
8.3.3	Replace the complete contact unit	23
	Required spare parts.....	23
	Required tools	23
	Disassembly	23
	Assembly	23
8.3.4	Replace the magnetic drive.....	24
	Required spare parts.....	24
	Required tools	24
	Disassembly	24
	Assembly	24
9.	Spare parts	25
10.	Technical data.....	26
11.	Disposal	26

1. Important basic information

1.1 Legal notes

Without prior written consent of Schaltbau GmbH, this manual is not allowed to be electronically or mechanically reproduced – as a whole or in parts – be distributed, changed, transmitted, translated into another language or used in any other way.

Schaltbau GmbH cannot be held liable for damage caused by not observing (or only partly observing) the manual.

1.2 Conventions for this manual

This manual describes the installation and maintenance of the contactors.

Cross references are presented in bold italics.

To highlight particularly important safety instructions and other information, the following symbols are used in this instructions:

DANGER

Indicates a hazardous situation with a high level of risk which, if not avoided, will result in death or serious injury.

WARNING

Indicates a hazardous situation with a medium level of risk which, if not avoided, could result in death or serious injury.

CAUTION

Indicates a hazardous situation with a low level of risk which, if not avoided, may result in minor or moderate injury.

NOTICE

Indicates a hazardous situation which, if not avoided, may result in property damage, such as service interruption or damage to equipment or other materials.



Refers to technical features and methods aimed at facilitating work or to particularly important information.

This manual refers to double pole NO contactors of the C295 series

This manual describes only stock items of the above mentioned contactor types. If you need a special variant feel free to contact us.

2. General and security information

The contactors dealt with in this document are intended for use with electrical systems for special installations. They are designed and tested in compliance with the generally recognised state of the art. However, improper use, operation, handling, maintenance or tampering with electric equipment can cause serious or fatal injury to the user or others, and the appliance or other property can be damaged.



The operation, maintenance and installation instructions for the contactors must therefore be strictly followed.

Any uncertainties must be clarified and all queries must include details of the type of device and the serial number.

Only authorized and trained personnel are allowed to plan and carry out all mechanical and electrical installations, transport, commissioning, as well as maintenance and repair work.

This applies to the observation of the general installation and safety regulations for work on electrical systems as well as the proper use of tools approved for this purpose. Electrical equipment requires protection from moisture and dust during installation, operation or storage.

2.1 Observing the instructions

-  All staff must read and understand the instructions in this manual and adhere to them when working with the device.
-  **Always carefully observe all safety warnings!**

2.2 User obligations

- ▶ Observe all applicable national provisions, all safety, accident prevention and environmental regulations as well as the recognized technical rules for safe and proper working.
- ▶ Carry out regular inspections of all protection and safety devices to see if they work properly.
- ▶ Work on electric equipment may only be performed by an expert or trained personnel working under the direction and supervision of an expert according to the applicable rules of electrical engineering.
- ▶ An expert is a person who can judge and recognise the possible dangers of the jobs assigned to him based on his training, knowledge and experience and by knowledge of the appropriate regulations.
- ▶ Work on the contactors must only be carried out by staff who meets the requirements set out in this manual.
- ▶ Staff must be informed clearly about who is responsible for the maintenance of the contactors.
- ▶ After each installation work and/or after any other modifications, alterations or maintenance works, always perform complete checks according to these standards:
 - EN/IEC 60077-2
 - EN/IEC 60947-4-1

2.3 Intended use

- ▶ The contactors have been designed and tested according to national and international standards. Due to their unique features they can also be used in a variety of applications.
- ▶ The contactors must only be used under operating conditions according to the technical specification and the instructions in this manual.
- ▶ None of the operating conditions defined in the corresponding data sheets and in our *catalogue B295* in section "*Specifications*", such as voltages, currents, ambient conditions, etc. may be changed. The *catalogue* is available under: <https://www.schaltbau.com/en/media-library/>
- ▶ The contactors may only be used when all protective devices are present, have been installed properly and are fully operational.
- ▶ The contactors must not be contaminated with aggressive media.
- ▶ Contactors may not be used without further protective measures in potentially explosive atmospheres.

- ▶ The contactor meets the requirements of basic insulation. Make sure the frame or plate onto which the drive of the contactor is mounted is earthed in a shock and vibration resistant way.
- ▶ Coil suppression for reducing surges when the coil is switched off is optimally attuned to the contactor's switching behaviour. The existing opening characteristic must not be negatively influenced by parallel connection with an external diode.
- ▶ The contactor has unprotected live parts
- ▶ The required clearance of live parts to earth and other parts of the contactor is to be observed as well as the safety regulations of the applicable standards.
- ▶ Switching at maximum breaking capacity might require larger clearance! Do not hesitate to ask our advice for dimensioning.
- ▶ Improper handling of the contactors, e.g. when hitting the floor with some impact, can result in breakage, cracks and deformation. Always handle the contactors with care.
- ▶ Use the contactor only according to its intended use. Replace or repair damaged parts exclusively with original parts. Any other usage of or tampering with the contactors is considered contrary to its intended use. No liability is assumed for damages and accidents caused due to non-compliance with the instructions in this manual or improper use of the contactors.

2.4 Ambient conditions

NOTICE

The contactors are constructed for specific ambient conditions.

- ▶ Operate the contactors only according to the ambient conditions, like temperature ranges, pollution degree, etc., as defined in the corresponding data sheets and in our *catalogue B295*. The *catalogue* is available under: <https://www.schaltbau.com/en/media-library/>

3. Dangers and security measures

3.1 Electrical dangers

	<p>⚠ DANGER</p>
	<p>The contactors are used to switch voltage. The touching of electrically conducting parts may result in serious injuries or even death!</p> <p>Energized parts are all metal parts belonging directly to one of the circuits or wires leading there. All other visible metal parts and wires may also be energized in the case of a failure.</p> <p>Before beginning any work on the contactors, always observe the following safety regulations:</p> <ul style="list-style-type: none"> ▶ Disconnect on all sides ▶ Ensure that it is not possible to reconnect unintentionally ▶ Clearly mark your work area ▶ Make sure that there is no voltage present ▶ Earth and short circuit the installation; this also includes the discharging of any capacitors in the main circuit ▶ Besides the main electric circuit, also disconnect additional and auxiliary circuits ▶ Cover or insulate adjacent energized parts ▶ Only an electrically skilled person may determine if there is no voltage present ▶ When the work has been concluded, proceed the other way round.

3.2 Other dangers

	<p>⚠ WARNING</p>
	<p>Exclusively use the contactors for purposes as indicated in the specifications and data sheets. A wrong application can cause accidents and severe damages to persons!</p> <ul style="list-style-type: none"> ▶ The manufacturer doesn't take the responsibility for accidents which were caused by improper use of the product.

	<p>⚠ CAUTION</p>
	<p>During continuous operation the contactors may become hot. Risk of burns!</p> <ul style="list-style-type: none"> ▶ Before beginning any checks or maintenance work on the contactors make sure that the heated components have cooled down.

	<p>⚠ CAUTION</p>
	<p>The contactors contain sharp-edged parts. Risk of injury!</p> <ul style="list-style-type: none"> ▶ Use appropriate tools for installation and maintenance works on the contactors. ▶ Wear protective gloves when working with sharp-edged components.

3.3 Measures for avoiding damages and malfunctions

NOTICE

Aggressive fluids may damage the contactors.

- ▶ Make sure that the contactors are not exposed to aggressive fluids.

NOTICE

Improper handling of the contactors, e.g. when hitting the floor with some impact, can result in breakage, cracks and deformation.

- ▶ Make sure that the contactors are always used properly.
- ▶ Do not throw the contactors to the floor.
- ▶ Regularly sight-check the contactors for potential damages.
- ▶ Immediately replace damaged components.

NOTICE

Depending on the product type, contactors can contain strong (permanent) magnets. These magnets can attract ferromagnetic particles and may damage the contactors.

- ▶ Make sure that the contactors are installed at a location, where no ferromagnetic particles can be attracted.

NOTICE

Depending on the product type, contactors can contain strong (permanent) magnets. These magnets can destroy data on credit cards or similar cards.

- ▶ Keep credit cards or similar cards away from the contactors..

NOTICE

During the switching off, strong electromagnetic fields are generated in the surroundings of the contactors. These may influence other components close to the contactors.

- ▶ Make sure that the contactors are installed at a location, where no other components can be affected.

NOTICE

In the case of damage, wear and tear and/or soiling of the contactor components - in the form of a partial break, sharp edges and discoloured surfaces - the functional safety of the contactors is no longer guaranteed.

- ▶ Carry out regular visual checks to detect wear and tear and dirt.
- ▶ Immediately replace damaged parts.
- ▶ Immediately remove dirt without leaving any residues.
- ▶ Immediately replace parts with stubborn dirt.

NOTICE

Detent-edged rings and detent-edged washers have a limited life time. After 3 times opening of screws secured with detent-edged rings or detent-edged washers, the rings or washers must be replaced by new ones.

- ▶ Record the frequency of screw opening in the work log.
- ▶ After 3 times opening of screws, replace detent-edged rings or detent-edged washers by new ones..

4. Product information

4.1 Double pole NO contactor, C295 series

Compact double-pole high-voltage NO contactor for DC and AC

With its compact size and efficient arc chute our C295 Series contactor allows the handling of voltages up to 1,500 V and currents of 120 A max.

Switching high amperage even at significant inductance can be achieved by series connection of the main contacts, whereas parallel connection results in longer contact life.

4.2 Features

- ▶ Compact in size
- ▶ Double-break contacts
- ▶ With magnetic blowout for DC arc quenching
- ▶ Switching of high inductive loads by means of main contacts connected in series
- ▶ Parallel connection: Longer life of main contacts

4.3 Applications

Typical applications are to be found in traffic engineering equipment, particularly in heating circuits, air conditioning equipment and conversion engineering of complex power supplies.

4.4 Technical information and material specification

For technical information and material specifications, refer to the corresponding data sheets and to our *catalogue B295*. The *catalogue* is available under:

<https://www.schaltbau.com/en/media-library/>

4.5 Overview

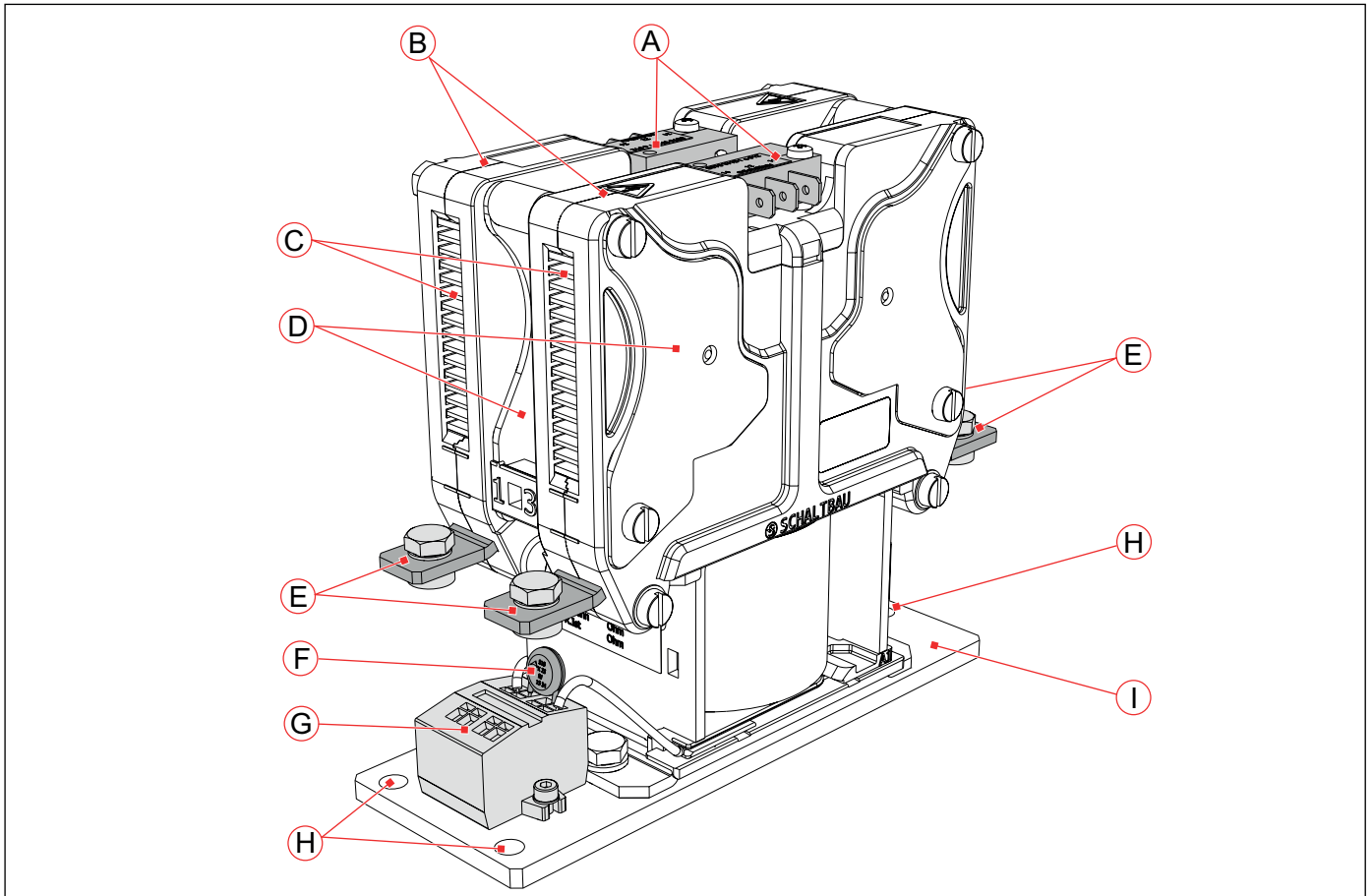

Fig. 1: Overview C295 series

- A Auxiliary contacts (2x S870), Terminals: Flat tabs 6.3 x 0.8 mm
- B Arc chambers
- C Plasma exits
- D Permanent magnets
- E Main contacts, Terminals: M6, Tightening torque: 6 Nm max.
- F Coil suppression: Varistor
- G Coil terminals: Cage clamp
- H Mounting holes for screws M6, Tightening torque depends on the property class (min. 8.8) of the screws/nuts used
- I Base plate

5. Storage

NOTICE

Moisture and dust can damage the contactor. If the device is to be stored for a prolonged period of time,

- ▶ store it in its original packaging,
- ▶ store it in a dry and dust-free location.

Return shipments

Schaltbau recommends to keep the original packing box for any return shipments. If no original packing box is available care must be taken to pack the contactor in a way that prevents damage during shipment.

6. Unpacking

6.1 Unpack the device

- ▶ Before opening the packaging, perform a visual inspection for any signs that could indicate damage having occurred during transport (impacts, bumps, falling etc.).
- ▶ If any signs indicate that the contactor has been subject to excessive shock influence do not install the contactor.

6.2 Check parts for transport damage

NOTICE

If parts are damaged, the functional reliability of the contactor is no longer given.

- ▶ Before installing, check all parts for any possible transport damage.
- ▶ Do not install a damaged contactor.

7. Installation

7.1 Mechanical installation

7.1.1 Dimensions and further technical specifications

The dimensions and further technical specifications are given in the respective data sheets or in our catalogue. Refer to our *catalogue B295*.

The *catalogue* is available under:

<https://www.schaltbau.com/en/media-library/>

7.1.2 Preliminaries

- ▶ An appropriate mounting plate or mounting frame has to be provided for the fastening of the device. The mounting plate or frame must be solid enough to carry the weight of the device under the expected shock and vibration conditions.
- ▶ 3 mounting holes must be prepared on the mounting plate or frame according to *Fig. 2*.

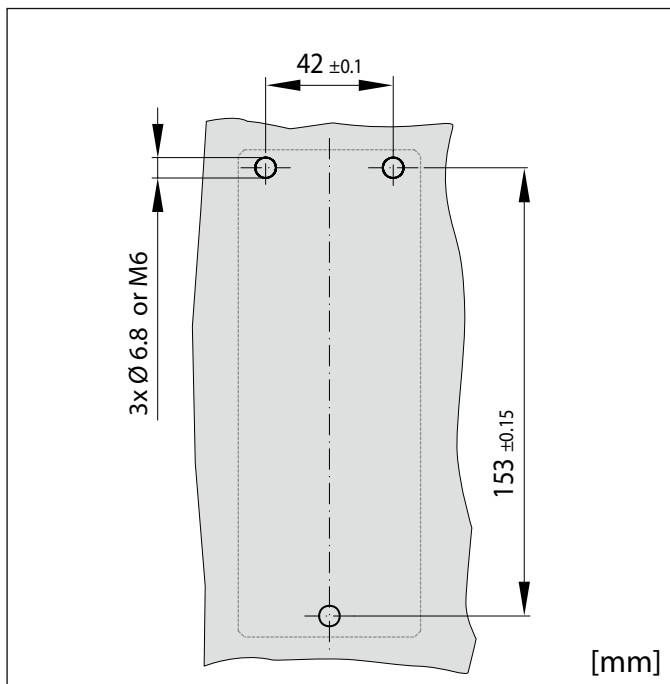

Fig. 2: Dimensions and arrangement of the mounting holes

- ▶ The mounting holes can be prepared in two ways:
 - either as threaded holes (for threaded screws)
 - or as through-holes (for threaded screws and nuts)

- ▶ The contactors are fixed to the mounting plate or frame with 3 mounting screws M6.
 - The length of the fixing screws has to be determined according to the constructional conditions.
 - In order to secure the mounting screws against self-loosening, appropriate screw locking elements have to be provided. Schaltbau strongly recommends Schnorr-Washers (or similar) to secure the screws.
 - The tightening torque depends on the property class (min. 8.8) of the screws/nuts used.

7.1.3 Correct mounting positions

The contactors can be installed at the prepared mounting plate or frame in almost any installation position. Examples of intended mounting positions are shown in *Fig. 3*.

Not permitted are hanging installation positions with the mounting plate/mounting frame facing upwards, as shown for example in *Fig. 4*.

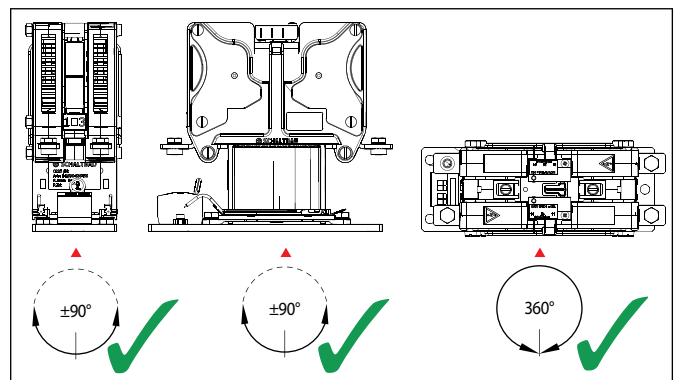

Fig. 3: Examples for intended mounting positions

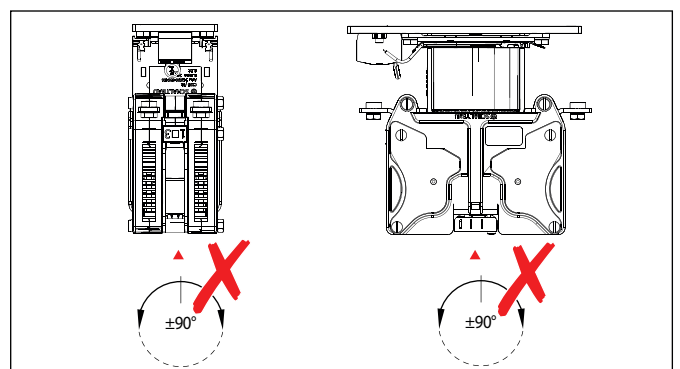

Fig. 4: Examples of not permissible mounting positions

7.1.4 Required minimum clearance

NOTICE

Switching electrical currents at high voltages will produce arcing and plasma may exit out of the arc chambers. It is essential to observe the minimum clearance towards earthed and live parts to avoid the risk of a flash-over.

- ▶ The required minimum clearance to all sides and upwards can be found in our *catalogue B295*. The catalogue is available under:
<https://www.schaltbau.com/en/media-library/>

7.1.5 Ventilation requirements

- ▶ The installation space must be adequately ventilated, especially if severe shutdowns are expected. This will allow the plasma to decompose more quickly and reduce the risk of flashover and corrosion.

7.1.6 Safety

- ▶ The installation has to be carried out by qualified trained personnel.

NOTICE

During installation, ensure that dirt caused by surrounding construction activities does not get into the contactor.

NOTICE

Detent-edged rings and detent-edged washers have a limited life time. After 3 times opening of screws secured with detent-edged rings or detent-edged washers, the rings or washers must be replaced by new ones.

- ▶ Record the frequency of screw opening in the work log.
- ▶ After 3 times opening of screws, replace detent-edged rings or detent-edged washers by new ones.

7.1.7 Required tools

- Socket wrench set, hexagon nuts
- Open-end wrench set
- Hexagon socket wrench set
- Torque wrench

7.1.8 Install the contactor

- ▶ Make sure, that the mounting surfaces of the mounting plate (3) or frame and the lower side of the contactor are free from dirt and other contamination (e. g. metal cuttings).
- ▶ Place the contactor (1) on the mounting plate (3) or frame provided with the mounting holes.
- ▶ Screw the contactor (1) to the mounting plate (3) or frame using the 3 mounting screws (2).
 - If the mounting holes are designed as threaded holes, screw the screws with suitable screw locking elements directly into the prepared threads.
 - If the mounting holes are through holes, tighten the screws with suitable screw locking elements (on both sides) and nuts.
- ▶ Then tighten the mounting screws (2) with a torque depending on the property class (min. 8.8) of the screws/nuts used.

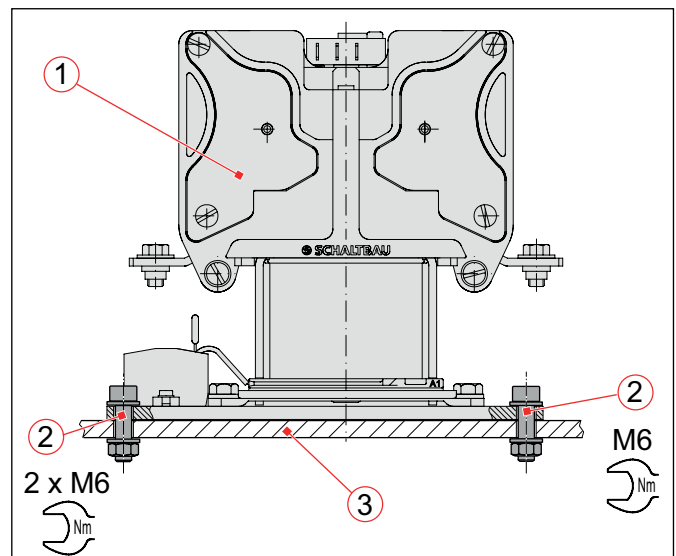

Fig. 5: Install the contactor to the mounting plate or frame

7.2 Electrical installation

7.2.1 Electrical data and further technical specifications

For the power consumption of the magnetic drive system and electrical data of the auxiliary switches refer to the respective data sheets and to our *catalogue B295*.



The *catalogue* is available under:

<https://www.schaltbau.com/en/media-library/>

7.2.2 Preliminaries

- ▶ The connection of the main current circuit can be done with wires or busbars.
- ▶ If wires are used, the wire gauges must be selected in coordination with their insulation class and the ambient conditions.
- ▶ The minimum cross sections for the conventional thermal current I_{th} of the connection cables/busbars are specified in our *catalogue B295* and must be observed. The *catalogue* is available under: <https://www.schaltbau.com/en/media-library/>
- ▶ The cables of the main current circuit must be fitted with appropriate ring cable lugs (for terminal screws M6).
- ▶ Schaltbau recommends Schnorr-Washers (or similar) to secure the terminal screws against self-loosening.
- ▶ The terminal screws must be tightened with a torque of 6 Nm.
- ▶ The terminals of the the auxiliary contacts are designed as flat tabs. Therefore the control wires must be fitted with appropriate blade receptacles (6.3 x 0.8 mm) for tabs.
- ▶ The maximum permissible cross section of the auxiliary contact control cables is 1 mm²/AWG 18 stranded wire.
- ▶ The control wires for the coil connection are connected with cage clamp terminals and must be stripped accordingly.

7.2.3 Safety

 DANGER	
	<p>The contactors are used to switch voltage. The touching of electrically conducting parts may result in serious injuries or even death!</p> <p>Energized parts are all metal parts belonging directly to one of the circuits or wires leading there. All other visible metal parts and wires may also be energized in the case of a failure.</p> <p>Before beginning any work on the contactors, always observe the following safety regulations:</p> <ul style="list-style-type: none"> ▶ Disconnect on all sides ▶ Ensure that it is not possible to reconnect unintentionally ▶ Clearly mark your work area ▶ Make sure that there is no voltage present ▶ Earth and short circuit the installation; this also includes the discharging of any capacitors in the main circuit ▶ Besides the main electric circuit, also disconnect additional and auxiliary circuits ▶ Cover or insulate adjacent energized parts ▶ Only an electrically skilled person may determine if there is no voltage present ▶ When the work has been concluded, proceed the other way round.

NOTICE

Detent-edged rings and detent-edged washers have a limited life time. After 3 times opening of screws secured with detent-edged rings or detent-edged washers, the rings or washers must be replaced by new ones.

- ▶ Record the frequency of screw opening in the work log.
- ▶ After 3 times opening of screws, replace detent-edged rings or detent-edged washers by new ones.

7.2.4 Required tools

- Socket wrench set, hexagon nuts
- Open-end wrench set
- Torque wrench
- Continuity tester
- Cable ties

7.2.5 Connect the auxiliary contacts

NOTICE

Make sure that according to the insulation coordination there is sufficient clearance between the wires of the control voltage and the main connections.

NOTICE

- ▶ The maximum permissible cross section of the auxiliary contact control wires is 1 mm² / AWG 18 stranded wire.
- ▶ Bending of the auxiliary contact terminals is not permissible!
- ▶ Move and lay the control wires and blade receptacles only in plugging direction, see **Fig. 6**.
- ▶ Secure the control wires mechanically, in order to minimize effects of cable forces (e. g. shock, vibrations) to the terminals.

The control wires for the auxiliary contacts must be fitted with appropriate blade receptacles (6.3 x 0.8 mm).

- ▶ Plug the prepared control wires with the blade receptacles (1) to the terminals (2) of the auxiliary contacts.
- ▶ If necessary, bundle and fix the cables with cable ties.

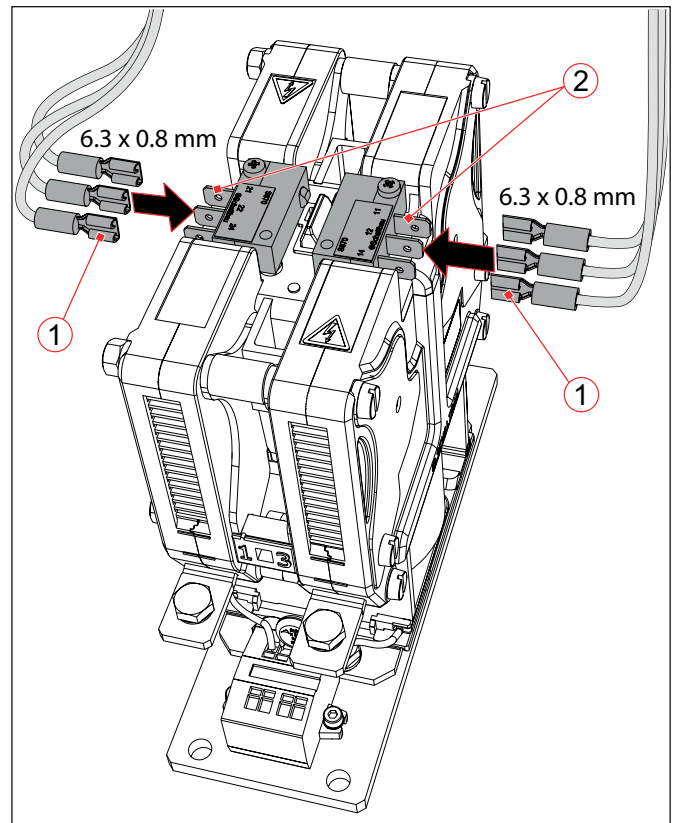

Fig. 6: Connect the S870 auxiliary contacts

7.2.6 Connect the coil terminals

NOTICE

The value of the overvoltage limitation is part of the magnetic system and must not be changed and in particular must not be short-circuited (e. g. by an external diode).

- ▶ Make sure that no such diode is used in your control system.

NOTICE

Secure the control wires mechanically, in order to minimize effects of cable forces (e. g. shock, vibrations) to the terminals.

NOTICE

Make sure that according to the insulation coordination there is sufficient clearance between the wires of the control voltage and the main connections.

The control wires for the coil connection are connected with cage clamp terminals and must be stripped accordingly.

- ▶ Connect the prepared stripped control wires (4) to the cage clamp terminals (5) on the terminal block (5).
- ▶ Check that the cables are firmly fixed.
- ▶ If necessary, bundle and fix the cables with cable ties.

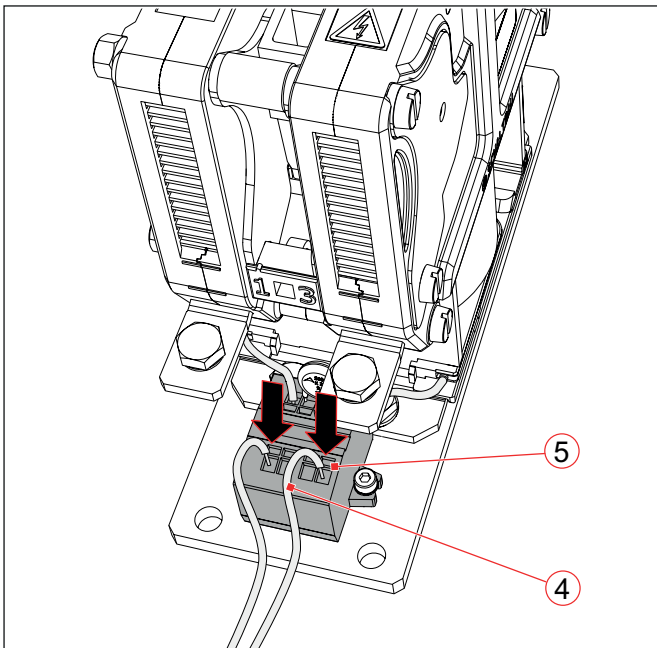

Fig. 7: Connect the coil terminals

7.2.7 Connect the main contacts

NOTICE

Make sure, that the connection points of the main contacts are free from corrosion.

Main contact connection with cables

The wires of the main current circuit must be fitted with appropriate ring cable lugs (for terminal screws M6). An Example of the connection with cables is shown in Fig. 8.

- ▶ Lay the prepared connection cables (3) to the main contacts (1).
- ▶ Place the ring cable lugs (2) on the main contacts (1).

NOTICE

Make sure that according to the insulation coordination there is sufficient clearance between the main terminals and the pole plates.

- ▶ Screw the ring cable lugs (2) to the main contacts (1) using the terminal screws (4) and washers (5).
 - Schaltbau recommends Schnorr-Washers (or similar) to secure the terminal screws.
- ▶ Tighten the terminal screws (4) with a torque of max. 6 Nm.

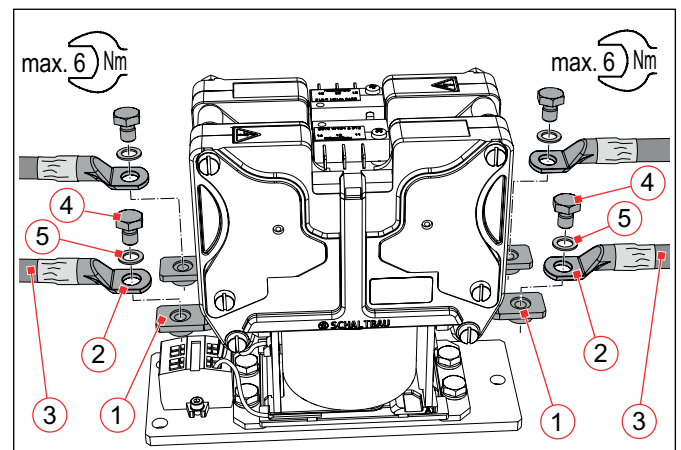

Fig. 8: Connect the main contacts (example for the connection with cables)

Main contact connection with busbars

As an alternative to the connection with cables, the main circuit can also be connected with busbars. Examples for the connection with busbars are shown in Fig. 9 to Fig. 11.

- Lay the busbars (7) to the main contacts (1).

NOTICE

Make sure that according to the insulation coordination there is sufficient clearance between the main terminals and the pole plates.

- Depending on the installation situation, use additional connecting bars (6) or angled connecting bars (8) if necessary.
- Connect the busbars (7) to the connecting bars (6) or angled connecting bars (8) using appropriate screws and washers.
 - Schaltbau recommends Schnorr-Washers (or similar) to secure the screws.
- Connect the connecting bars (6) or angled connecting bars (8) to the main terminals (1) using the terminal screws (4) and washers (5).
 - Schaltbau recommends Schnorr-Washers (or similar) to secure the screws.
- Tighten the terminal screws (4) with a torque of max. 6 Nm.

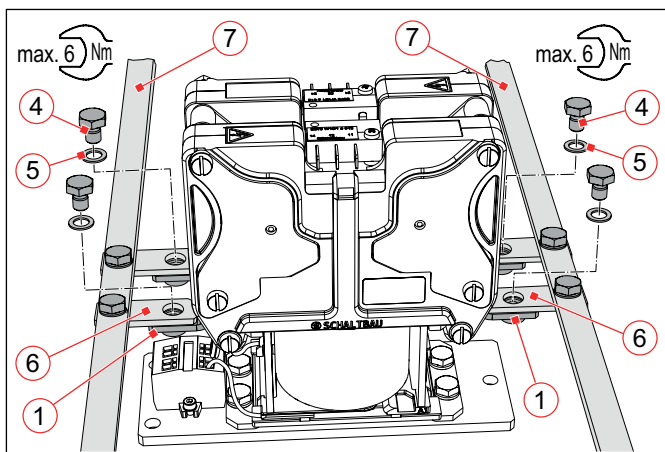

Fig. 9: Connect the main contacts (example for the connection with busbars (7) and connecting bars(6))

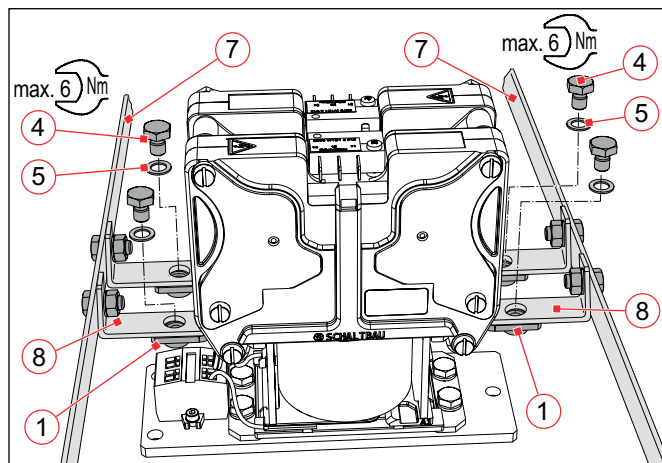

Fig. 10: Connect the main contacts (example of parallel connection with busbars (7) and angled connecting bars (8))

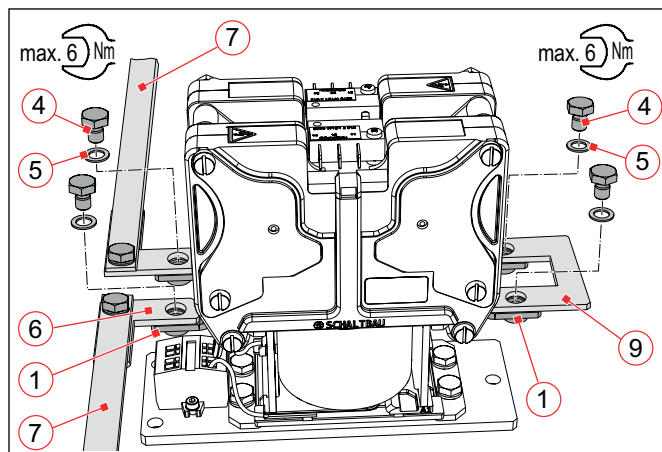

Fig. 11: Connect the main contacts (example for series connection with with busbars (7), connecting bars (6) and contact bridge (9))

7.3 Checks

After the installation is completed, do the following checks:

- ▶ Check that the contactors are correctly installed on the mounting plate/frame and fit tightly.
- ▶ Check that the cables or busbars are correctly installed and fit tightly at the main contacts.
- ▶ Check that the control wires of the coil terminals are correctly installed.
- ▶ Check that the control wires are properly connected to the auxiliary switches.
Use a continuity tester to check that the wiring is correct and the auxiliary switches are functioning correctly.
- ▶ Switch the contactor several times without load.
- ▶ Perform a functional test (undervoltage, dropp-off voltage of the contactor) according to Schaltbau requirements. Refer to *catalogue B295*.
- ▶ Check the laying of cables. Cables must not be squeezed or bent. If applicable bundle and secure with cable ties.
- ▶ After each installation and after maintenance works, always perform complete checks according to these standards:
 - EN/IEC 60077-2
 - EN/IEC 60947-4-1

8. Maintenance

Note the expert knowledge which is essential for carrying out maintenance work, mentioned in chapter "2. General and security information".

8.1 Safety

⚠ DANGER



The contactors are used to switch voltage. The touching of electrically conducting parts may result in serious injuries or even death!

Energized parts are all metal parts belonging directly to one of the circuits or wires leading there. All other visible metal parts and wires may also be energized in the case of a failure.

Before beginning any work on the contactors, always observe the following safety regulations:

- ▶ Disconnect on all sides
- ▶ Ensure that it is not possible to reconnect unintentionally
- ▶ Clearly mark your work area
- ▶ Make sure that there is no voltage present
- ▶ Earth and short circuit the installation; this also includes the discharging of any capacitors in the main circuit
- ▶ Besides the main electric circuit, also disconnect additional and auxiliary circuits
- ▶ Cover or insulate adjacent energized parts
- ▶ Only an electrically skilled person may determine if there is no voltage present
- ▶ When the work has been concluded, proceed the other way round.

8.2 Preventive maintenance

Contactors of the C295 series are maintenance-free within the rated mechanical life time. The electrical life time depends on the number of switchings under heavy load conditions and may vary for different applications. In normal use, this corresponds to a decade-long operating period.

Unscheduled checks are only necessary if there has been a significant number of switching operations under overload and short circuit conditions.

8.2.1 Intervals for regular checks

To ensure the correct function and a prolonged operational life span of the contactors, the following checks and maintenance must be performed regularly.

Checks	Interval
Visual inspection of the contactor from outside	▶ 1x per year
Inspection of the main contacts	▶ Every 2 years
Inspection of the auxiliary switches	▶ Every 2 years

If the contactors are operated in particularly dirty environments, the checking intervals for visible inspections should be shortened, because dirt can impair the insulation clearances and there is therefore the possibility of a shorter service life or an operational fault.

⚠ DANGER



When damages on the contactor, cables or busbars are visible, the safety of the contactor is no longer guaranteed.

- ▶ Immediately give damaged contactors or components to corrective maintenance.

NOTICE

Detent-edged rings and detent-edged washers have a limited life time. After 3 times opening of screws secured with detent-edged rings or detent-edged washers, the rings or washers must be replaced by new ones.

- ▶ Record the frequency of screw opening in the work log.
- ▶ After 3 times opening of screws, replace detent-edged rings or detent-edged washers by new ones.

8.2.2 Regular check activities

All of the maintenance activities that may be carried out on the contactors by skilled personnel are listed below.

Component	Visual inspection	Measures
Cables/busbars	Check for: <ul style="list-style-type: none"> ▶ broken cables, cable lugs ▶ damaged insulation ▶ kinked or crushed cables ▶ damaged busbars ▶ loose or missing fastening elements ▶ correct tightening torque of the terminal screws 	In case of faults: <ul style="list-style-type: none"> ▶ immediately replace damaged cables or cable lugs ▶ immediately replace damaged busbars ▶ tighten loose fastening elements immediately replace missing fastening elements ▶ tighten the terminal screws with the rated torque
Auxiliary contacts	Check for: <ul style="list-style-type: none"> ▶ dirt ▶ damage or wear on the housing ▶ signs of short circuits The auxiliary contact is visible for a simple optical inspection from the outside. Under normal working conditions (if there were no short circuits in the control circuit) the life time of the auxiliary contacts exceeds that of the contactor many times over.	In case of faults: <ul style="list-style-type: none"> ▶ replace the auxiliary contacts, refer to section “8.3 Corrective maintenance” / “8.3.1 Replace the auxiliary contacts”.
Contactor housing	Check for: <ul style="list-style-type: none"> ▶ dirt ▶ damage or wear and tear ▶ penetrations, holes in the contactor housing wall ▶ loose or missing fastening elements 	In case of faults: <ul style="list-style-type: none"> ▶ remove existent dirt ▶ if the contactor housing is damaged or heavily worn replace the complete contactor unit, see section „8.3 Corrective maintenance” / „8.3.3 Replace the complete contact unit”. ▶ in case of penetrations, holes in the contactor housing wall replace the complete contactor unit, see section „8.3 Corrective maintenance” / „8.3.3 Replace the complete contact unit”. ▶ tighten loose fastening elements and immediately replace missing fastening elements ▶ tighten a loose contactor
Main contacts (both, fixed contacts and movable contact bridge) Contact unit complete	To test the main contacts, the complete contact unit must first be removed, see section “8.3 Corrective maintenance”/“8.3.2 Check the main contacts” The main contacts are then accessible and can be checked for: <ul style="list-style-type: none"> ▶ damage or wear and tear ▶ traces of burn-off (slight sooting permissible) It requires some experience to evaluate the state of the contacts. Even after only a few switchings under load the contacts look used and “polluted” for the inexperienced eye. The main contacts only need to be replaced when the minimum height of the contact tip is less than 0.7 mm (new condition 1.5 mm).	In case of faults: <ul style="list-style-type: none"> ▶ if the contact material on one of the contacts on the contact bridge or on the fixed contacts has burned away to less than 0.7 mm minimum height, replace the complete contact unit, see section „8.3 Corrective maintenance” / „8.3.3 Replace the complete contact unit”.

Component	Visual inspection	Measures
Magnetic drive unit	Check for: <ul style="list-style-type: none"> ▶ dirt ▶ damage or heavy wear and tear ▶ damage due to operation with impermissible, too high coil voltage 	In case of faults: <ul style="list-style-type: none"> ▶ if damaged or heavily worn, replace the complete magnetic drive unit, see section “8.3 Corrective maintenance” / „8.3.4 Replace the magnetic drive“.

8.3 Corrective maintenance

The contactors are maintenance-free. There is therefore no general need to replace parts during their service life.

However, if an excessive number of emergency shut-downs or damage has occurred during operation, Schaltbau offers original spare parts.

⚠ WARNING



The use of unsuitable parts can lead to accidents and serious personal injury due to malfunctions.

- ▶ Only use original spare parts!
- ▶ Do not combine single parts from different contactors!

8.3.1 Replace the auxiliary contacts

Under normal working conditions (if there were no short circuits in the control circuit) the life time of the auxiliary contacts exceeds that of the contactor many times over.

However, in case of a short circuit in the control circuit it can happen that the auxiliary contacts have been damaged and must be replaced.

Required spare parts

- Auxiliary contact assembly (2 auxiliary contacts with self-tapping screws), see chapter **„9. Spare parts“**.

Required tools

- Phillips screwdriver set
- Torque wrench
- Continuity tester

Disassembly

⚠ DANGER



Before beginning any work on the contactors, make sure that

- ▶ there is no voltage present,
- ▶ all safety regulations are fully observed.
- ▶ Refer also to section **“8.1 Safety”**.

NOTICE

The auxiliary contacts are printed differently. Incorrect installation of the auxiliary contacts leads to malfunctions and can destroy the contactor.

- ▶ Before disassembly, note the position of the contact numbering on the labels of the auxiliary contacts.

- ▶ Disconnect the control wires from the auxiliary contacts.
- ▶ Loosen and remove the self-tapping screws (1) on the auxiliary contacts (2).
- ▶ Remove the auxiliary contacts (2) from the upper part of the contactor.

Assembly

NOTICE

Incorrect installation of the auxiliary contacts leads to malfunctions and can destroy the contactor.

- ▶ Before mounting, observe the previously noted position of the contact numbering on the labels of the auxiliary contacts.
- ▶ Place the new auxiliary contacts (2) (with the printed label facing upwards) so that the locking pin (3) engages in the second hole of the auxiliary contact.
- ▶ Slightly screw on both auxiliary contacts (2) with new self-tapping screws (1).
- ▶ If necessary, align the auxiliary contacts (2).
 - The auxiliary contacts must switch safely!
- ▶ Tighten the new self-tapping screws (1) with a torque of max. 0.8 Nm.
- ▶ Connect the control wires to the new auxiliary contacts (2), see section **"7.2.5 Connect the auxiliary contacts"**.
- ▶ Check that the control wires are correctly connected to the auxiliary contacts.
- ▶ Use a continuity tester to check the correct assignment and correct functioning of the auxiliary contacts.
- ▶ Finally, make a complete check of the contactor as described in section **"7.3 Checks"**.

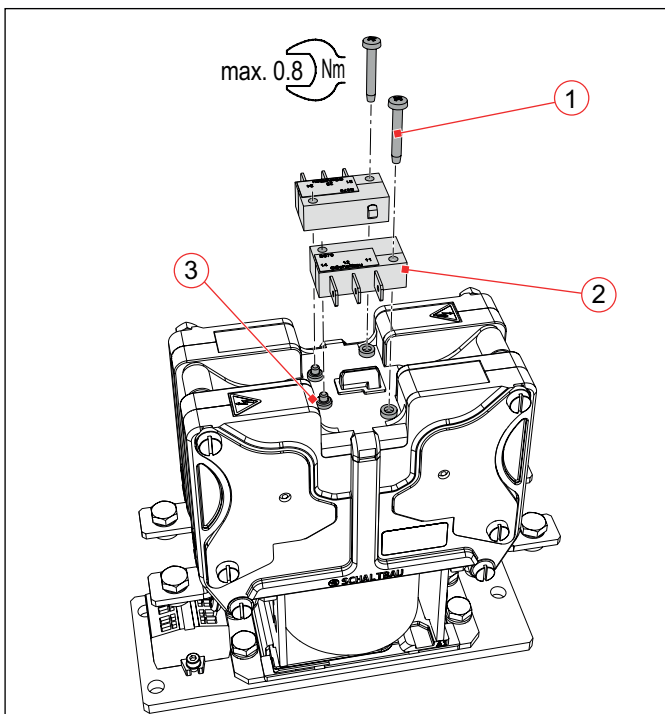

Fig. 12: Replace the auxiliary contacts

8.3.2 Check the main contacts

If the contact material on one of the contacts on the contact bridge or on the fixed contacts has burned away to less than 0.7 mm minimum height, replace the complete contact unit.

Preliminaries

To check the main contacts, the complete contact unit must first be removed, see section **"8.3.3 Replace the complete contact unit" / "Disassembly"**.

Required tools

- Slotted screwdriver set
- Suitable measuring tool for measuring the minimum height of the contact tip, e.g. caliper gauge
- Continuity tester
- Torque wrench

Check the main contacts for wear and tear

	⚠ DANGER
	<p>Before beginning any work on the contactors, make sure that</p> <ul style="list-style-type: none"> ▶ there is no voltage present, ▶ all safety regulations are fully observed. ▶ Refer also to section "8.1 Safety".

NOTICE

Incorrect installation of the cover (5) and the contact bridge (6) due to two possible mounting positions leads to malfunctions and can destroy the contactor. Before disassembly:

- ▶ Note the orientation of the cover (5) in relation to the contact unit housing (2).
- ▶ When correctly installed, the fixing screws of the auxiliary contacts point in the direction of the main contacts "2" and "4".
- ▶ Note the orientation of the contact bridge (6) in relation to the housing of the contact unit (2).

NOTICE

Never loosen the screws (4) on the side of the contact unit. Otherwise, arc quenching sheets and other parts inside the contact unit may fall out of their supports. The risk of incorrect mounting is very high.

- ▶ First remove the complete contact unit, see section **“8.3.3 Replace the complete contact unit” / “Disassembly”**.
- ▶ Note the orientation of the cover (5) in relation to the housing of the contact unit (2).
- ▶ Remove the cover (5) from the contact unit (2).
- ▶ Note the orientation of the contact bridge (6) in relation to the housing of the contact unit (2).
- ▶ Remove the contact bridge (6) from the contact unit (2).

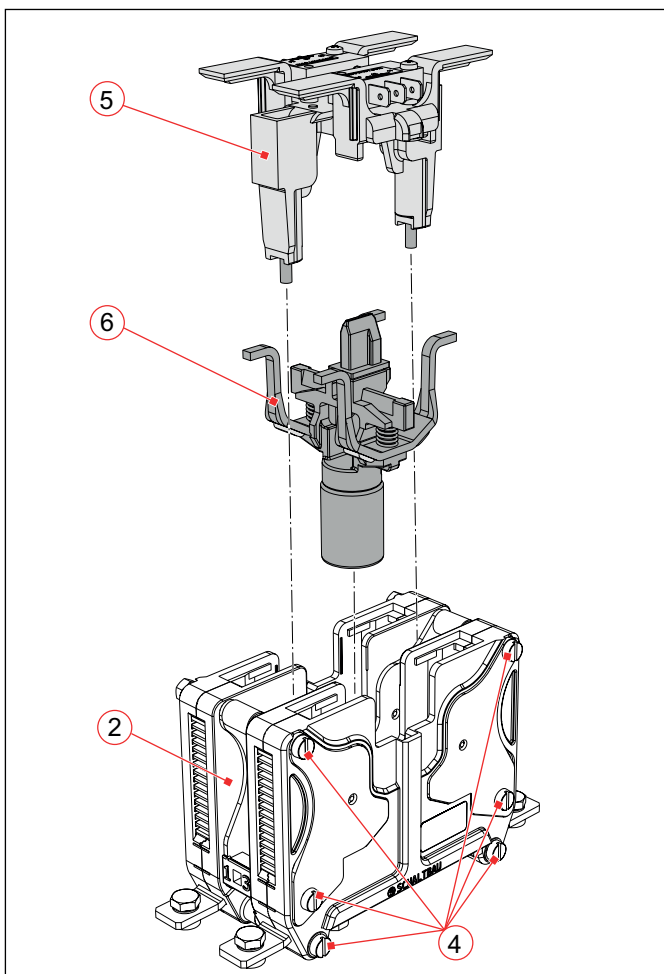

Fig. 13: Remove the cover and the contact bridge

- ▶ Check the main contacts. In doing so
 - check the contacts (7) on the bottom side of the movable contact bridge,
 - as well as the stationary fixed contacts (8) in the housing of the contact unit.

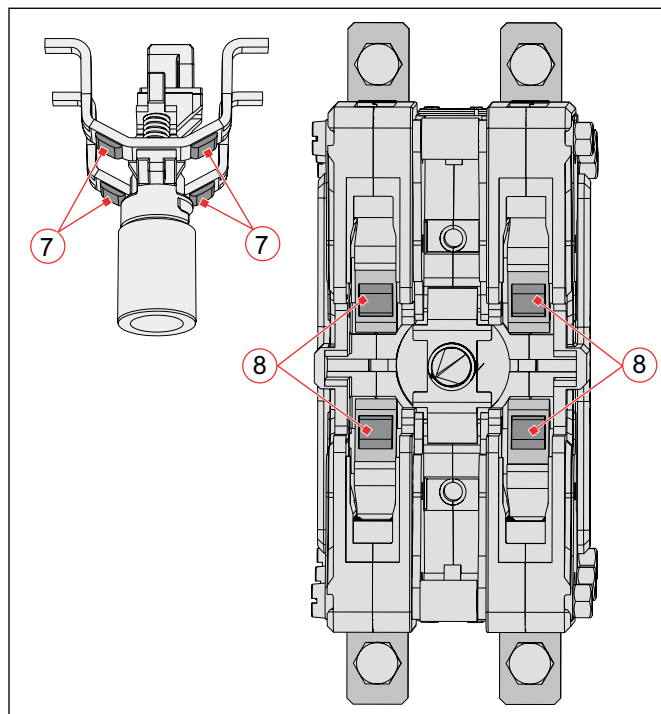

Fig. 14: Check the main contacts

If the contacts are burned off or worn out:

- ▶ If the contact material on one of the contacts on the contact bridge (7) or on the fixed contacts (8) has burned away to less than 0.7 mm minimum height, replace the complete contact unit, see section **„8.3.3 Replace the complete contact unit“**.

If the contacts are not burned off and not worn out:

NOTICE

Incorrect installation of the cover and the contact bridge due to two possible mounting positions leads to malfunctions and can destroy the contactor.

Before assembling:

- ▶ Observe the previously noted, correct orientation of the contact bridge in relation to the housing of the contact unit.
- ▶ Observe the previously noted correct orientation of the cover in relation to the housing of the contact unit.

When correctly installed, the fixing screws of the auxiliary contacts point in the direction of the main contacts “2” or “4”.

- ▶ Insert the contact bridge (6) in the correct position in the contact unit (2).

- ▶ Place the cover (5) in the correct position on the contact unit (2).
- ▶ Check all parts for correct assembly and correct fit.
- ▶ Then reassemble the complete contact unit on the magnetic drive, see section **“8.3.3 Replace the complete contact unit” / “Assembly”**.
 - The torque for the mounting screws is max. 1.5 Nm.
- ▶ Reconnect all connecting cables or busbars (main contacts, auxiliary contacts and if necessary coil connections), see section **“7.2 Electrical installation”**.
- ▶ Finally, make a complete check of the contactor as described in section **“7.3 Checks”**.

8.3.3 Replace the complete contact unit

Required spare parts

- Contact unit complete, depending on contactor type, see chapter **„9. Spare parts“**

Required tools

- Slotted screwdriver set
- Continuity tester
- Torque wrench

Disassembly

	⚠ DANGER
	<p>Before beginning any work on the contactors, make sure that</p> <ul style="list-style-type: none"> ▶ there is no voltage present, ▶ all safety regulations are fully observed. ▶ Refer also to section “8.1 Safety”.

NOTICE
<p>Incorrect installation of the contact unit due to two possible mounting positions leads to malfunctions and can destroy the contactor.</p> <ul style="list-style-type: none"> ▶ Before disassembly, note the orientation of the old contact unit in relation to the magnetic drive.

- ▶ Remove all connecting cables or busbars from the main contacts, auxiliary contacts and, if necessary, coil connections.

- ▶ Loosen the 2 screws (1) on the contactor cover (the screws need not be removed from the cover).
- ▶ Carefully lift the contact unit (2) off the magnetic drive (3).

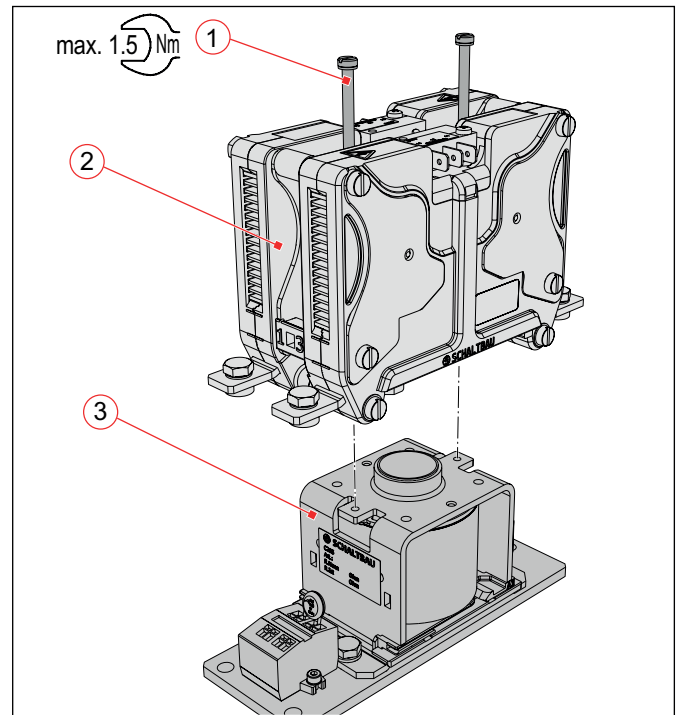

Fig. 15: Disassemble/assemble contact unit

Assembly

NOTICE
<p>Incorrect installation of the contact unit due to two possible mounting positions leads to malfunctions and can destroy the contactor.</p> <ul style="list-style-type: none"> ▶ Before assembling the new contact unit on the magnetic drive, make sure that the previously noted correct orientation in relation to the magnetic drive is observed.

- ▶ Place the new contact unit (2) in the correct position on the magnetic drive (3) and screw it on with the two screws (1).
- ▶ Tighten the two screws (1) with a torque of max. 1.5 Nm.
- ▶ Reconnect all connecting cables or busbars (main contacts, auxiliary contacts and if necessary coil connections), see section **“7.2 Electrical installation”**.
- ▶ Finally, make a complete check of the contactor as described in section **“7.3 Checks”**.

8.3.4 Replace the magnetic drive

Required spare parts

Magnetic drive with specified coil voltage depending on the contactor type. See chapter "9. Spare parts".

Required tools

- Slotted screwdriver set
- Continuity tester
- Torque wrench

Disassembly

	<p>⚠ DANGER</p>
	<p>Before beginning any work on the contactors, make sure that</p> <ul style="list-style-type: none"> ▶ there is no voltage present, ▶ all safety regulations are fully observed. ▶ Refer also to section "8.1 Safety".

<p>NOTICE</p>
<p>Incorrect installation of the contact unit due to two possible mounting positions leads to malfunctions and can destroy the contactor.</p> <ul style="list-style-type: none"> ▶ Before disassembly, note the orientation of the contact unit in relation to the magnetic drive.

- ▶ Remove all connecting cables or busbars from the main contacts, auxiliary contacts and coil connections.
- ▶ Remove the contactor from the mounting plate or mounting frame, see also section "7.1.8 Install the contactor".
- ▶ Loosen the 2 screws (1) on the contactor cover (the screws need not be removed from the cover).
- ▶ Carefully lift the contact unit (2) off the magnetic drive (3).

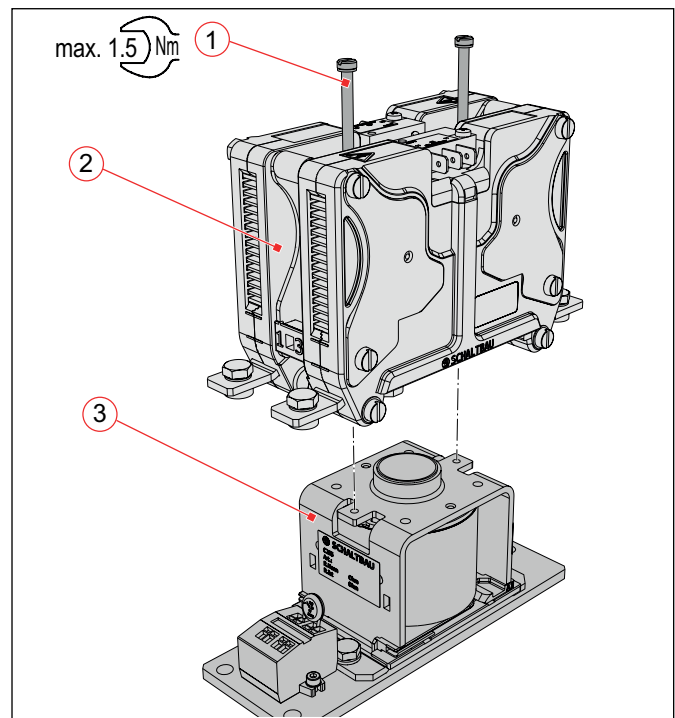

Fig. 16: Magnetantrieb demontieren/montieren

Assembly

<p>NOTICE</p>
<p>Incorrect installation of the contact unit due to two possible mounting positions leads to malfunctions and can destroy the contactor.</p> <ul style="list-style-type: none"> ▶ Before assembling the contact unit on the magnetic drive, make sure that the previously noted correct orientation in relation to the magnetic drive is observed.

- ▶ Place the contact unit (2) in the correct position on the magnetic drive (3) and screw it on with the two screws (1).
- ▶ Tighten the two screws (1) with a torque of max. 1.5 Nm.
- ▶ Install the contactor back on the mounting plate or mounting frame, see also section "7.1.8 Install the contactor".
- ▶ Reconnect all connecting cables or busbars (main contacts, auxiliary contacts and coil connections), see section "7.2 Electrical installation".
- ▶ Finally, make a complete check of the contactor as described in section "7.3 Checks".

9. Spare parts



Important!

Depending on the type of contactor, different types of spare parts must be used. Therefore always provide the exact type and article number of the contactor when ordering spare parts. You will find the information on the rating plate.

Designation	Parts
Auxiliary contact assembly	Auxiliary contacts (2 pieces) with self-tapping screws
Contact unit complete	Contact unit complete (housing with fixed contacts, contact bridge, armature and auxiliary contacts)
Magnetic drive	Base plate, coil unit with yoke and coil connection

10. Technical data

Technical data for C295 series contactors can be found in our *catalogue B295*.

Due to our continuous improvement programme, the design of our products can be modified at any time. So some features may differ from the descriptions, specifications and drawings in the catalogues. You can download the latest update of the catalogue at: <https://www.schaltbau.com/en/media-library/>

The updated catalogues render the previous issues invalid.

11. Disposal

This product is designed for exclusive professional use by commercial companies. The owner is responsible for ensuring an environmentally sound disposal of this product at the end of its working life.

This product or parts of it may not be disposed with other household wastes.

To prevent possible harm to the environment or human health from uncontrolled waste disposal, please separate this product or parts of it from other types of wastes and recycle it responsibly to promote the sustainable reuse of material resources.

Please observe all local regulations and recommendations for the disposal, recycling or environmentally friendly processing of the parts and materials that have been used or replaced during installation, operation, and maintenance tasks.

In the end-of life ensure an environmentally sound disposal of the product according to the legal regulations and requirements for electric and electronic waste equipment in your country.

Schaltbau GmbH

For detailed information on our products and services visit our website – or give us a call!

Schaltbau GmbH
Hollerithstrasse 5
81829 Munich
Germany



Phone +49 89 9 30 05-0
Fax +49 89 9 30 05-350
Internet www.schaltbau.com
e-Mail contact@schaltbau.de

with compliments:



The production facilities of Schaltbau GmbH have been IRIS certified since 2008.



Certified to DIN EN ISO 14001 since 2002. For the most recent certificate visit our website.



Certified to DIN EN ISO 9001 since 1994. For the most recent certificate visit our website.

Electrical Components and Systems for Railway Engineering and Industrial Applications

Connectors

- Connectors manufactured to industry standards
- Connectors to suit the special requirements of communications engineering (MIL connectors)
- Charging connectors for battery-powered machines and systems
- Connectors for railway engineering, including UIC connectors
- Special connectors to suit customer requirements

Snap-action switches

- Snap-action switches with positive opening operation
- Snap-action switches with self-cleaning contacts
- Enabling switches
- Special switches to suit customer requirements

Contactors

- Single and multi-pole DC contactors
- High-voltage AC/DC contactors
- Contactors for battery powered vehicles and power supplies
- Contactors for railway applications
- Terminal bolts and fuse holders
- DC emergency disconnect switches
- Special contactors to suit customer requirements

Electrics for rolling stock

- Equipment for driver's cab
- Equipment for passenger use
- High-voltage switchgear
- High-voltage heaters
- High-voltage roof equipment
- Equipment for electric brakes
- Design and engineering of train electrics to customer requirements