

3

Contactors

C195 series

Single pole
compact universal
NO and CO contactors

Installation and maintenance
instructions

Manual B195-M.en



Document Revision History

Date	Rev. version	Description	Pages
2021-02-10	1.0	First release	All
2022-10-14	2.0	Spare parts reduction	33-57
2022-10-27	3.0	Safety notice added Minor corrections to text	33 39, 42, 50, 55

Content

1. Important basic information	4
1.1 Legal notes.....	4
1.2 Conventions for this manual	4
2. General and safety information	4
2.1 Observing the manual.....	4
2.2 Duties of the operating company	5
2.3 Intended use	5
2.4 Ambient conditions.....	5
3. Hazards and safety precautions.....	6
3.1 Electrical hazards.....	6
3.2 Other hazards	6
3.3 Measures for avoiding damage and malfunctions.....	7
4. Product information.....	8
4.1 C195 Series – Single pole NO and changeover contactors plus bidirectional variants	8
4.2 Features.....	8
4.3 Applications	8
4.4 Technical information and material properties.....	8
4.5 Overview (stock items).....	9
5. Storage.....	17
6. Unpacking.....	17
6.1 Unpacking the device.....	17
6.2 Check parts for transport damage.....	17
7. Installation	18
7.1 Mounting.....	18
7.1.1 Dimensions/interfaces and further technical specifications.....	18
7.1.2 Preparatory measures.....	18
7.1.3 Mounting positions	19
7.1.4 Required minimum clearances.....	19
7.1.5 Ventilation requirements.....	19
7.1.6 Safety	19
7.1.7 Tools required.....	19
7.1.8 Installing the contactor	20

7.2	Electrical connection.....	21
7.2.1	Electrical data and other technical specifications	21
7.2.2	Preparatory measures.....	21
7.2.3	Safety	22
7.2.4	Tools required	22
7.2.5	Connecting the auxiliary switches	23
7.2.6	Connecting the coil	25
7.2.7	Connecting the main contacts.....	27
7.3	Connecting the earth terminal (only for C195 X/).....	31
7.4	Checks	31
8.	Maintenance.....	32
8.1	Safety	32
8.2	Preventive maintenance	32
8.2.1	Intervals for regular tests/checks.....	32
8.2.2	Regular tests/checks	33
8.3	Corrective maintenance measures – type C195 X/	35
8.3.1	Preparatory disassembly/assembly steps – type C195 X.....	35
8.3.2	Disassembling/assembling the pole packs – Typ C195 X/	35
8.3.3	Removing/attaching the pole plates – type C195 X/	36
8.3.4	Disassembling/Assembling the auxiliary switches – type C195 X/	37
8.3.5	Disassembling/assembling the contact unit – type C195 X/	38
8.3.6	Disassembling/assembling the armature – Typ C195 X/	39
8.3.7	Removing/attaching the cover – type C195 X/	40
8.3.8	Disassembling/assembling the magnetic drive – type C195 X/.....	42
8.3.9	Disassembling/assembling the arcing chambers – type C195 X/	43
8.3.10	Replacing the auxiliary switches – type C195 X/	45
8.3.11	Replacing the complete contact unit – type C195 X/	45
8.3.12	Replacing the armature – type C195 X/.....	45
8.3.13	Replacing the magnetic drive – type C195 X/.....	45
8.3.14	Replacing the arcing chambers – type C195 X/	45
8.4	Corrective maintenance measures – type C195 A/, B/, S/, T/, W/	46
8.4.1	Preparatory disassembly/assembly steps – type C195 A/, B/, S/, T/, W/	46
8.4.2	Disassembling/Assembling the auxiliary switches – type C195 A/, B/, S/, T/.....	46
8.4.3	Disassembling/assembling the contact unit – type C195 A/, B/, S/, T/, W/	49
8.4.4	Disassembling/assembling the armature – type C195 A/, B/, S/, T/, W/	51
8.4.5	Removing/attaching the cover – type C195 A/, B/, S/, T/, W/	53
8.4.6	Disassembling/assembling the magnetic drive – type C195 A/, B/, S/, T/, W/	54
8.4.7	Disassembling/assembling the arcing chamber – type C195 A/ and C195 B/	56
8.4.8	Replacing the auxiliary switches – type C195 A/, B/, S/, T/	57
8.4.9	Replacing the complete contact unit – type C195 A/, B/, S/, T/, W/	57
8.4.10	Replacing the armature – type C195 A/, B/, S/, T/, W/	57
8.4.11	Replacing the magnetic drive – type C195 A/, B/, S/, T/, W/.....	57
8.4.12	Replacing the arcing chambers – type C195 A/and C195 B/	57
9.	Spare parts.....	58
10.	Technical data.....	59
11.	Disposal	59

1. Important basic information

1.1 Legal notes

Without prior written consent of SCHALTBAU GmbH, this manual is not allowed to be electronically or mechanically reproduced – as a whole or in parts – be distributed, changed, transmitted, translated into another language or used in any other way.

SCHALTBAU GmbH cannot be held liable for damage caused by non- or only partial observation of the manual.

1.2 Conventions for this manual

This manual describes the installation and maintenance of the contactors.

Cross references are presented in *bold italics*.

To highlight particularly important safety instructions and other information, the following symbols are used in this manual:

DANGER

Indicates a directly threatening dangerous situation. Death or severe injuries will result if it is not prevented.

WARNING

Indicates a possibly dangerous situation. Death or severe injuries may result if it is not prevented.

CAUTION

Indicates a possibly dangerous situation. Medium or minor injuries may result if it is not prevented.

ATTENTION

Indicates a possibly detrimental situation. If it is not prevented, assemblies, the system or property in its surroundings could be damaged.



Indicates technical features and methods to simplify working or indicates information of particular importance.

This manual describes single pole NO and changeover contactors of the C195 series.

This manual describes only stock items of the above mentioned contactor types. If you need a special variant feel free to contact us.

2. General and safety information

The contactors dealt with in this document are intended for use with electrical systems for special applications. They are designed and tested in compliance with generally accepted codes of practice. However, improper use, operation, handling, maintenance or tampering with electric equipment can cause serious or fatal injury to the user or others, and the appliance or other property can be damaged. Consequently, the operation, maintenance and installation instructions for the contactors must be strictly followed.

If anything is not clear, clarification must be sought with any queries stating the device type and the serial number.

Only authorised and trained personnel are allowed to plan and carry out all mechanical and electrical instal-

lations, transport, commissioning, as well as maintenance and repair work.

This applies to the observation of the general installation and safety regulations for electrical systems as well as the proper use of tools approved for this purpose. Electrical equipment requires protection from moisture and dust during installation, operation and storage.

2.1 Observing the manual

- ▶ All personnel must read and understand the instructions in this manual and adhere to them when working with the device.
- ▶ **Always adhere strictly to all safety instructions!**

2.2 Duties of the operating company

- ▶ Observe all applicable national regulations, all safety, accident prevention and environmental protection regulations as well as the recognised technical rules for safe and correct working.
- ▶ Regularly check all fitted protection and safety equipment for correct function.
- ▶ Work on electrical equipment must only be carried out by a qualified electrician or by instructed persons under the supervision and control of a qualified electrician in accordance with electrical regulations.
- ▶ A specialist is someone who, on the basis of their technical training, knowledge and experience as well as knowledge of the relevant regulations, is able to assess the work assigned to them and identify possible dangers.
- ▶ Work on the contactors must only be carried out by personnel who meet the requirements set out in this manual.
- ▶ Personnel must be clearly informed about who is responsible for the maintenance of the contactors.
- ▶ Always perform complete checks after any installation work and/or after any other conversions, alterations or maintenance, in accordance with the following standards:
 - EN/IEC 60077-2
 - EN/IEC 60947-4-1

2.3 Intended use

- ▶ The contactors have been designed and tested according to national and international standards. Due to their unique features they can also be used in a wide range of industrial applications.
- ▶ The contactors must only be used under operating conditions according to the technical specifications and the instructions in this manual.
- ▶ None of the conditions of use, such as voltages, currents or ambient conditions, defined in the corresponding technical data sheets or in our **B195 catalogue** may be overridden. The **catalogue** is available under:
<https://www.schaltbau.com/en/media-library/>
- ▶ The contactors may only be used when all protective devices are present, have been correctly installed and are fully operational.

- ▶ Contactors may not be used without other safety precautions in potentially explosive atmospheres and/or in aggressive media.
- ▶ The switching device meets the requirements of basic insulation. Make sure the frame or plate onto which the drive of the contactor is mounted is earthed in a shock and vibration resistant way.
- ▶ Coil suppression for reducing surges when the coil is switched off is optimally attuned to the contactor's switching behaviour. The existing opening characteristic must not be negatively influenced by parallel connection with an external diode.
- ▶ The device contains unprotected live parts.
- ▶ The prescribed clearances relative to other live parts or earth and other parts must be complied with as well as the safety regulations of the applicable standards.
- ▶ Switching at close to the maximum breaking capacity may require increased minimum clearances! Do not hesitate to ask our advice in respect of any dimensioning.
- ▶ Improper handling of the contactors, e.g. impacts on the floor, may result in breakage, cracks or deformation. Always handle the device with care.
- ▶ Only use the contactors for the specified application and only with original parts. Any other usage of or tampering with the contactors is considered contrary to their intended use. No liability is assumed for damages and accidents caused due to non-compliance with the instructions in this manual or improper use of the contactors.

2.4 Ambient conditions

ATTENTION

The contactors have been designed for specific ambient conditions.

- ▶ Only operate the contactors in ambient conditions, such as temperature ranges, degree of soiling, etc., as defined in the corresponding data sheets and in our **catalogue B195**. The **catalogue** is available under:

<https://www.schaltbau.com/en/media-library/>

3. Hazards and safety precautions

3.1 Electrical hazards

	<p>⚠ DANGER</p>
	<p>The contactors are used for high voltage switching. Contact with live electrical parts can result in serious injuries or even death! Live parts are all metal parts belonging directly to one of the circuits or wires connecting to them. All other visible metal parts and wiring may also be live if a fault exists. Before starting any work on the contactors, always comply with the following safety rules:</p> <ul style="list-style-type: none"> ▶ Disconnect on all sides ▶ Secure to prevent switching back on ▶ Clearly identify the working area ▶ Check that a voltage-free state exists ▶ Earth and short circuit; this includes discharging any capacitors in the main circuit ▶ Besides the main power circuits, also disconnect additional and auxiliary circuits ▶ Cover or insulate adjacent live parts ▶ The presence of a voltage-free state can only be clearly identified by a qualified electrician. ▶ When the work has been concluded, follow the procedure in reverse.

3.2 Other hazards

	<p>⚠ WARNING</p>
	<p>Contactors must only be used for the purposes specified in the specifications and data sheets. Incorrect use can cause accidents and severe personal injury.</p> <ul style="list-style-type: none"> ▶ The manufacturer will not be responsible for accidents arising from improper use of the product.

	<p>⚠ CAUTION</p>
	<p>During continuous operation the contactors may become hot. Risk of burns!</p> <ul style="list-style-type: none"> ▶ Before beginning any checks or maintenance on the contactors ensure that the heated components have cooled down.

	<p>⚠ CAUTION</p>
	<p>The contactors contain sharp-edged parts. Risk of injuries!</p> <ul style="list-style-type: none"> ▶ Use appropriate tools for installation and maintenance work on the contactors. ▶ Wear safety gloves when handling sharp-edged components.

3.3 Measures for avoiding damage and malfunctions

ATTENTION

Aggressive liquids may damage the contactors.

- ▶ Ensure the contactors do not come into contact with aggressive liquids.

ATTENTION

Improper handling of the contactors, e.g. dropping on the floor, can result in breaks, cracks and deformation.

- ▶ Ensure the contactors are always handled correctly.
- ▶ Do not throw the contactors on the floor.
- ▶ At regular intervals perform a visual check of the contactors for possible damage.
- ▶ Immediately replace any damaged parts.

ATTENTION

Depending on the product type, contactors can contain permanent magnets. Such magnets can attract ferromagnetic parts resulting in damage to the contactors.

- ▶ Ensure that the contactors are installed in a location where it is not possible for them to attract any ferromagnetic parts.

ATTENTION

Depending on the product type, contactors can contain permanent magnets. These permanent magnets can destroy the data on the magnetic strips of credit or similar cards.

- ▶ Keep credit or similar cards away from the contactors.

ATTENTION

During switching off, strong electromagnetic fields are generated in the vicinity of the contactors. These may influence other components close to the contactors.

- ▶ Make sure that the contactors are installed in a location where no other components are affected.

ATTENTION

In the case of damage, wear and/or soiling of the contactors - in the form of a partial break, sharp edges and discoloured surfaces - the functional reliability of the contactors is no longer ensured.

- ▶ Visually inspect the contactors regularly to detect wear and soiling.
- ▶ Replace damaged parts immediately.
- ▶ Immediately remove any soiling without leaving any residues.
- ▶ Immediately replace any parts with persistent soiling.

ATTENTION

Detent-edged rings and detent-edged washers have a limited life time. After screws secured with detent-edged rings or detent-edged washers have been undone three times, the rings or washers must be replaced by new ones.

- ▶ Record the frequency of undoing of the screws in the work log.
- ▶ Replace detent-edged rings or detent-edged washers with new ones after the screws have been undone three times.

4. Product information

4.1 C195 Series – Single pole NO and changeover contactors plus bidirectional variants

Compact universal contactors for battery voltages up to 220 V and high voltages up to 1,500 V

Being of compact size and featuring double-break contacts that are covered for the most part, the C195 Series contactors provide highperformance current breaking.

Depending on the version you choose C195 series contactors come with blowouts and/or arc chutes.

The coils are fitted as standard with varistors for limiting surge voltages. For coil terminal connections you do not need to observe polarity.

With the C195 X there is also a bidirectional version, for which the direction of the current is irrelevant, as required for battery storage systems of public utilities. And with 320 A, the C195 X is also characterised by a higher current-carrying capacity.

In addition to that, there is the option of a SPDT version of the C195 series contactor which has an added galvanically isolated NC contact.

4.2 Features

- ▶ Compact universal contactors up to 1,500 V
- ▶ Unidirectional, bidirectional and latching contactor variants
- ▶ Broad range of possible applications
- ▶ Suitable for years of continuous operation
- ▶ Intended for high ambient temperatures
- ▶ Double-break contacts that are covered for the most part
- ▶ Versions for AC and DC operation available
- ▶ DC versions coming with magnetic blowout
- ▶ Extended coil tolerance according to railway standard

4.3 Applications

The contactors are typically used:

- for traffic engineering equipment, particularly in heating circuits and for air conditioning (HVAC equipment)
- as line contactor in mainline AC and DC rail networks – or in combination with a precharging contactor for a host of applications in trains, multiple units, rail cars and light rail vehicles
- for central inverters of complex power supplies
- for battery storage systems of utilities, specifically in grid stabilisation where bidirectional switching is a requirement

4.4 Technical information and material properties

For technical information and material properties, refer to the corresponding data sheets and to our *B195 catalogue*. The *catalogue* is available under:

<https://www.schaltbau.com/en/media-library/>

4.5 Overview (stock items)

4.5.1 C195 X/ (Single pole NO AC / DC contactor, bidirectional)

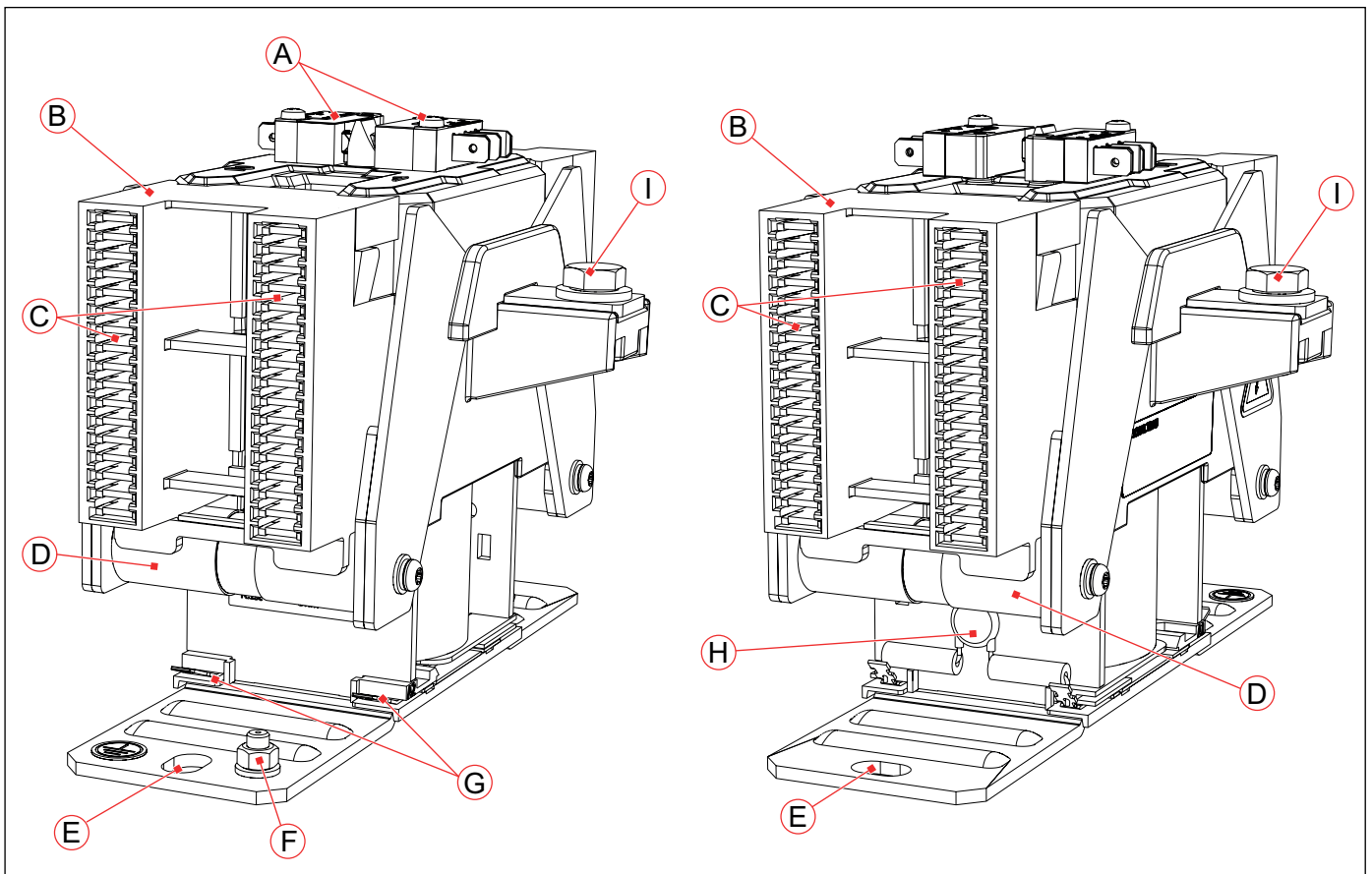

Fig. 1: C195 X/ (left: view from front, right: view from behind)

- A Auxiliary switches (2x S870): flat plug connections 6.3 x 0.8 mm
- B Arch chambers
- C Plasma-exits
- D Permanent magnets
- E Fastening holes for M8 screws
- F Earthing connection M5, torque: 2.4-3 Nm
- G Coil terminals A1 and A2, flat plug connections 6.3 x 0.8 mm
- H Coil suppression: Varistor
- I Main contacts, connection M8, torque: 8-10 Nm

4.5.2 C195 A/ (Single pole NO contactor, unidirectional DC)

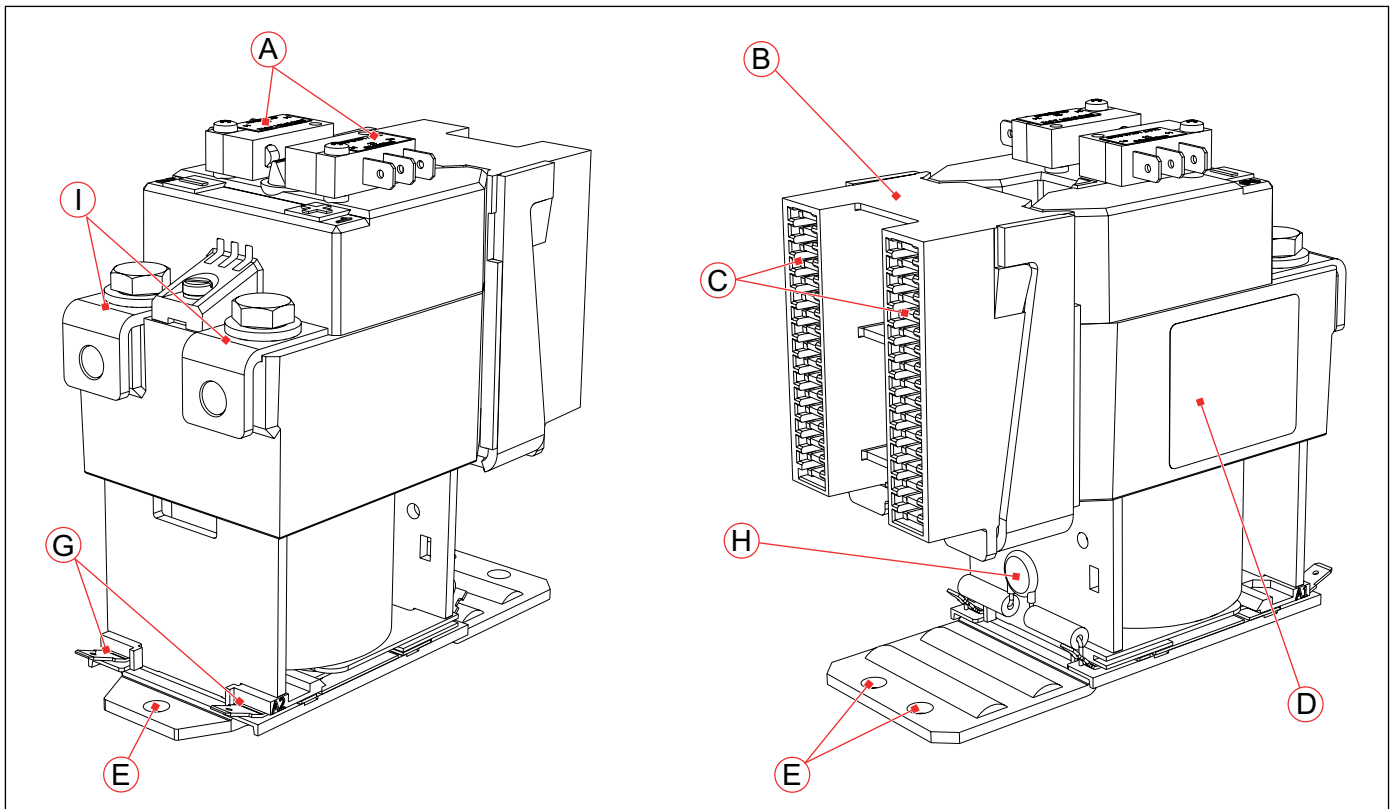

Fig. 2: C195 A/ (left: view from front, right: view from behind)

- A Auxiliary switches (2x S870): flat plug connections 6.3 x 0.8 mm
- B Arch chamber
- C Plasma-exits
- D Permanent magnet (inside the housing)
- E Fastening holes for M6 screws
- G Coil terminals A1 and A2, flat plug connections 6.3 x 0.8 mm
- H Coil suppression: Varistor
- I Main contacts, connection M8, torque: 9.5-12 Nm

4.5.3 C195 A/ ...BD (Single pole NO latching contactor, unidirectional DC)

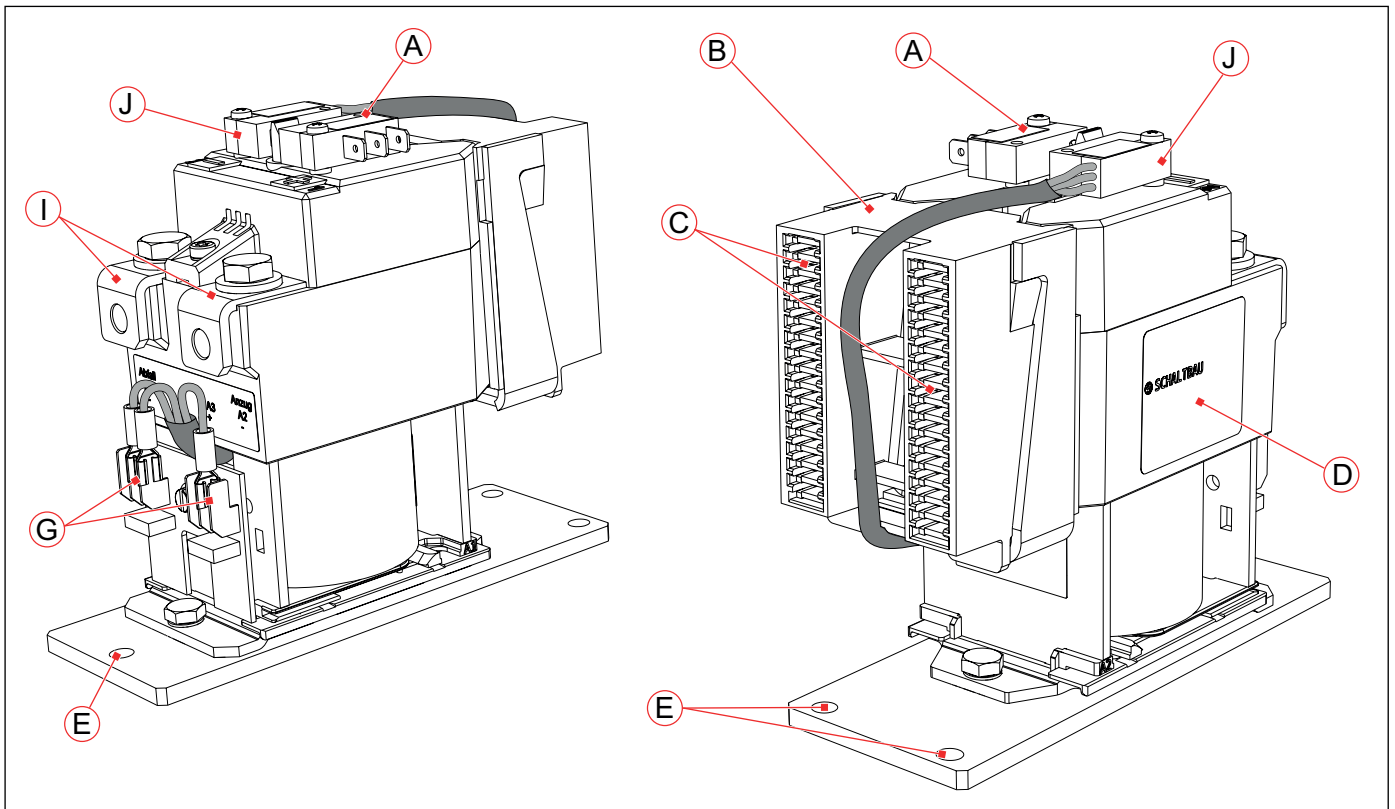

Fig. 3: C195 A/ ...BD (left: view from front, right: view from behind)

- A Auxiliary switch (1x S870) for customer use: flat plug connections 6.3 x 0.8 mm
- B Arch chamber
- C Plasma-exits
- D Permanent magnet (inside the housing)
- E Fastening holes for M6 screws
- G Coil terminals A1 and A2, flat plug connections 6.3 x 0.8 mm
- I Main contacts, connection M8, torque: 9.5-12 Nm
- J Auxiliary switch (1x S870 W1B1 a 065) for board switching (hard-wired)

4.5.4 C195 B/ (Single pole NO contactor AC)

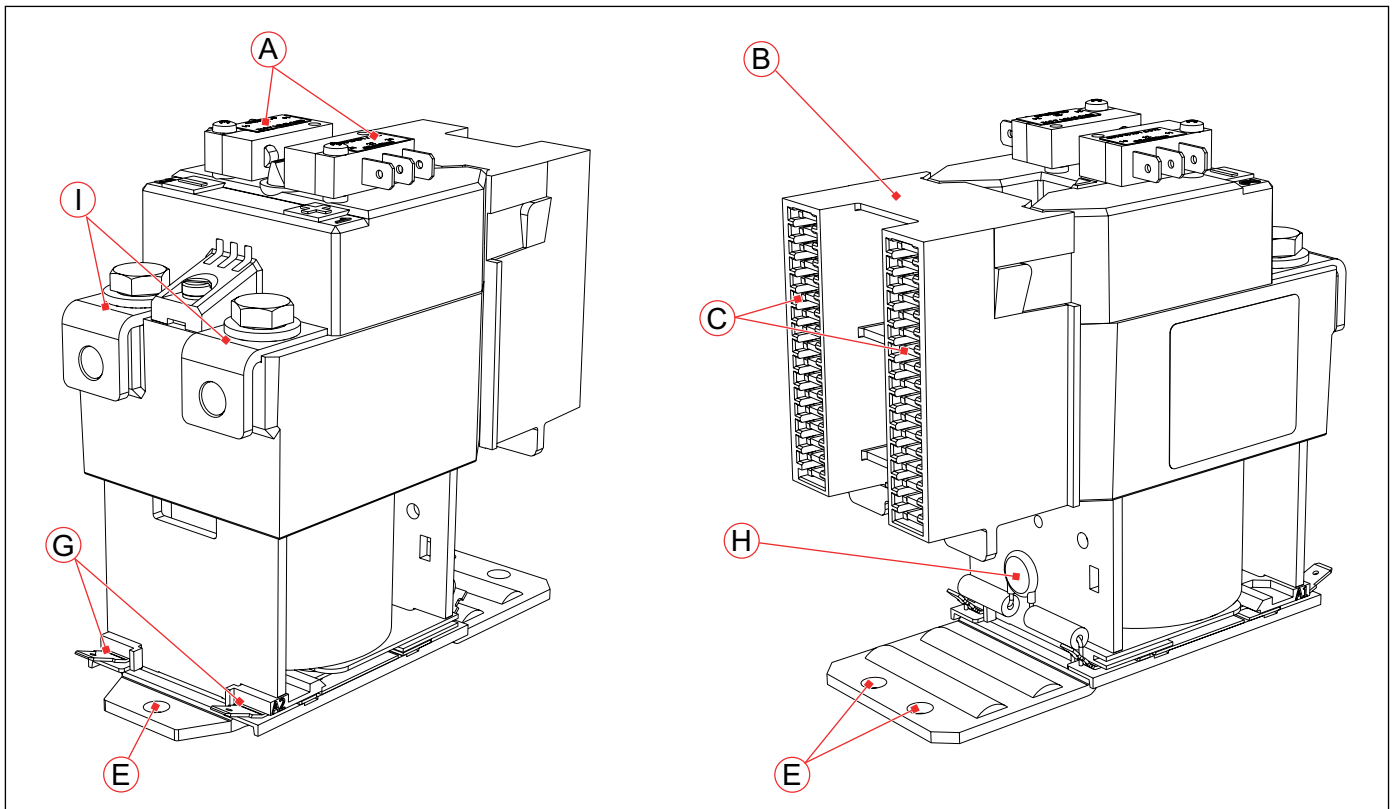

Fig. 4: C195 B/ (left: view from front, right: view from behind)

- A Auxiliary switches (2x S870), flat plug connections 6.3 x 0.8 mm
- B Arch chamber
- C Plasma-exits
- E Fastening holes for M6 screws
- G Coil terminals A1 and A2, flat plug connections 6.3 x 0.8 mm
- H Coil suppression: Varistor
- I Main contacts, connection M8, torque: 9.5-12 Nm

4.5.5 C195 S/ (Single pole NO contactor DC, unidirectional)

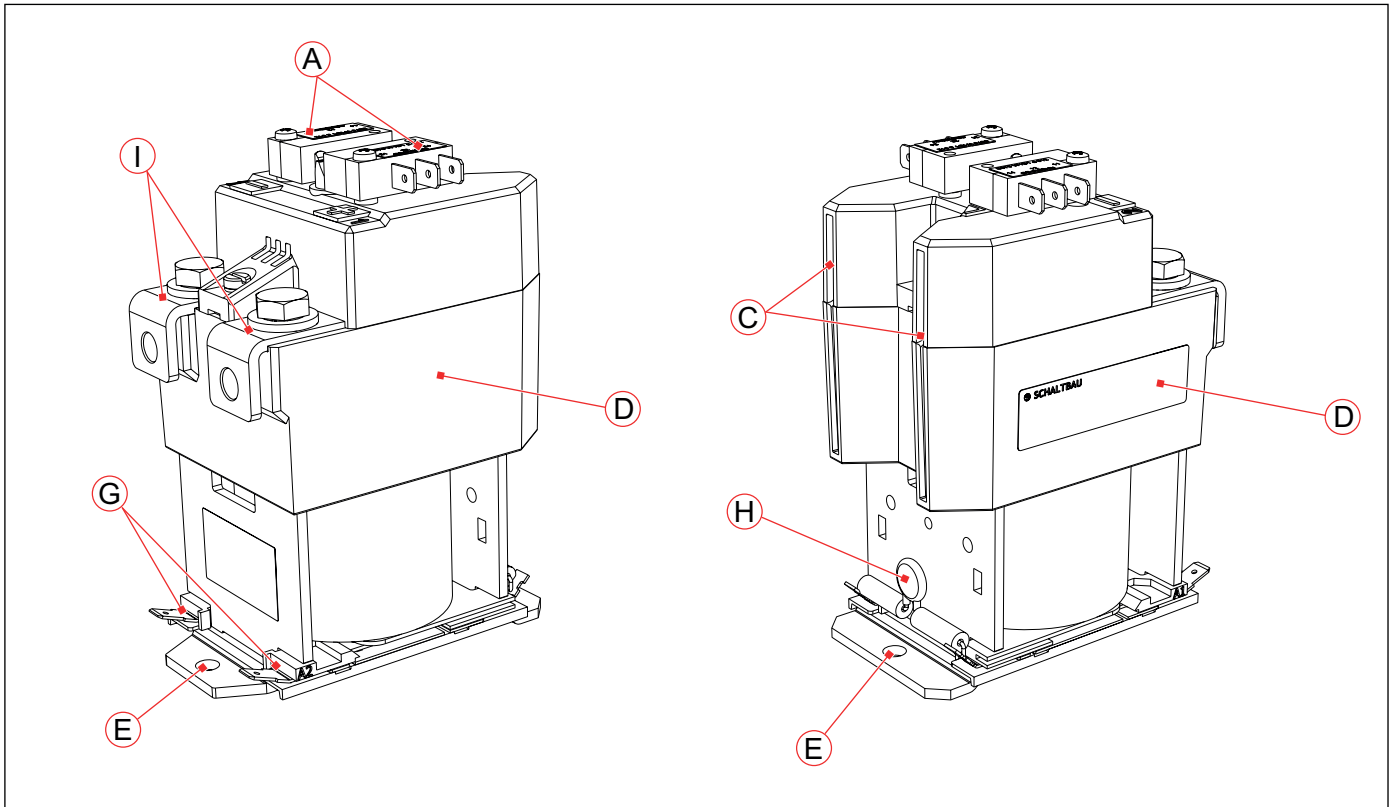

Fig. 5: C195 S/ (left: view from front, right: view from behind)

- A Auxiliary switches (2x S870), flat plug connections 6.3 x 0.8 mm
- C Plasma-exits
- D Permanent magnets (inside the housing)
- E Fastening holes for M6 screws
- G Coil terminals A1 and A2, flat plug connections 6.3 x 0.8 mm
- H Coil suppression: Varistor
- I Main contacts, connection M8, torque: 9.5-12 Nm

4.5.6 C195 S/ ...BD (Single pole NO latching contactor, unidirectional DC)

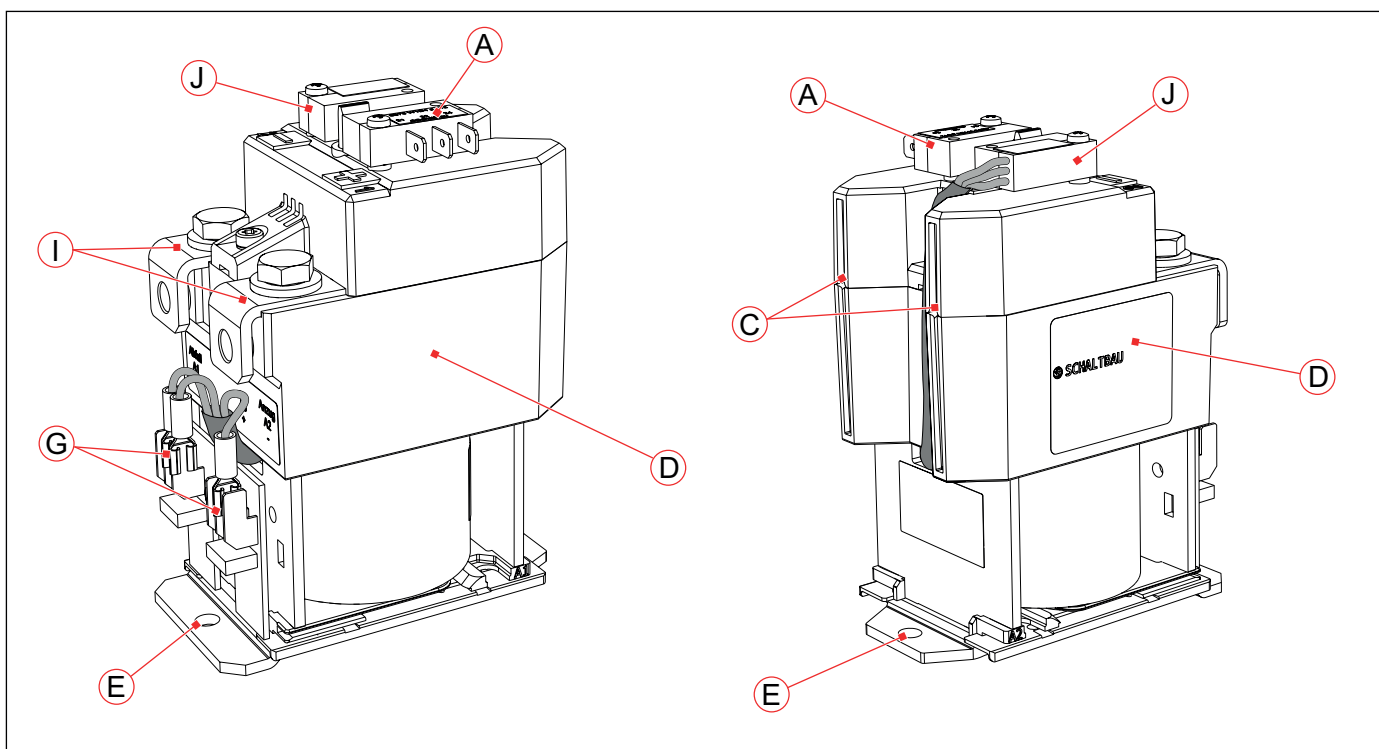

Fig. 6: C195 S/ ...BD (left: view from front, right: view from behind)

- A Auxiliary switch (1x S870) for customer use: flat plug connections 6.3 x 0.8 mm
- C Plasma-exits
- D Permanent magnet (inside the housing)
- E Fastening holes for M6 screws
- G Coil terminals A1 and A2, flat plug connections 6.3 x 0.8 mm
- I Main contacts, connection M8, torque: 9.5-12 Nm
- J Auxiliary switch (1x S870 W1B1 a 065) for board switching (hard-wired)

4.5.7 C195 T/ (Single pole NO contactor AC)

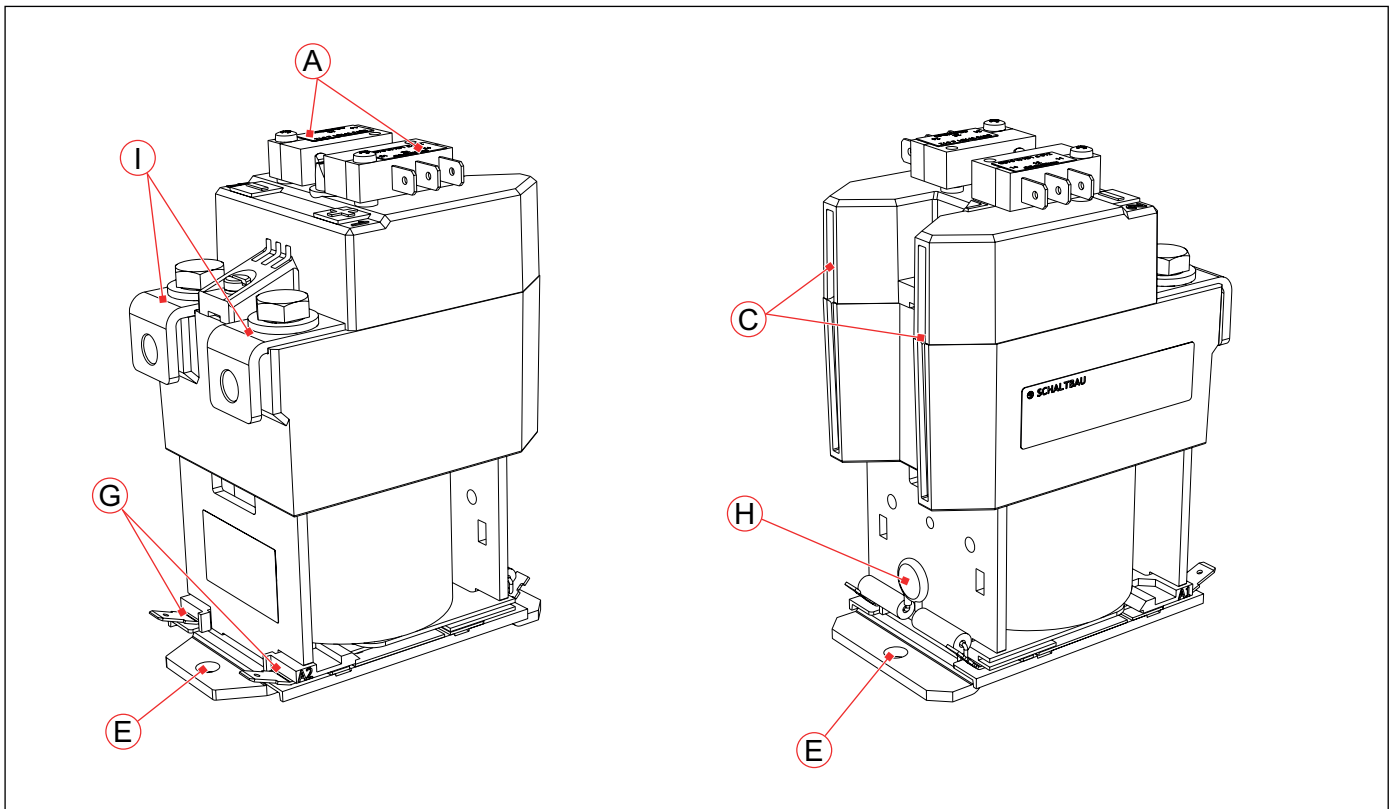

Fig. 7: C195 T/ (left: view from front, right: view from behind)

- A Auxiliary switches (2x S870): flat plug connections 6.3 x 0.8 mm
- C Plasma-exits
- E Fastening holes for M6 screws
- G Coil terminals A1 and A2, flat plug connections 6.3 x 0.8 mm
- H Coil suppression: Varistor
- I Main contacts, connection M8, torque: 9.5-12 Nm

4.5.8 C195 W/ (Single pole changeover (SPDT) contactor, unidirectional DC)

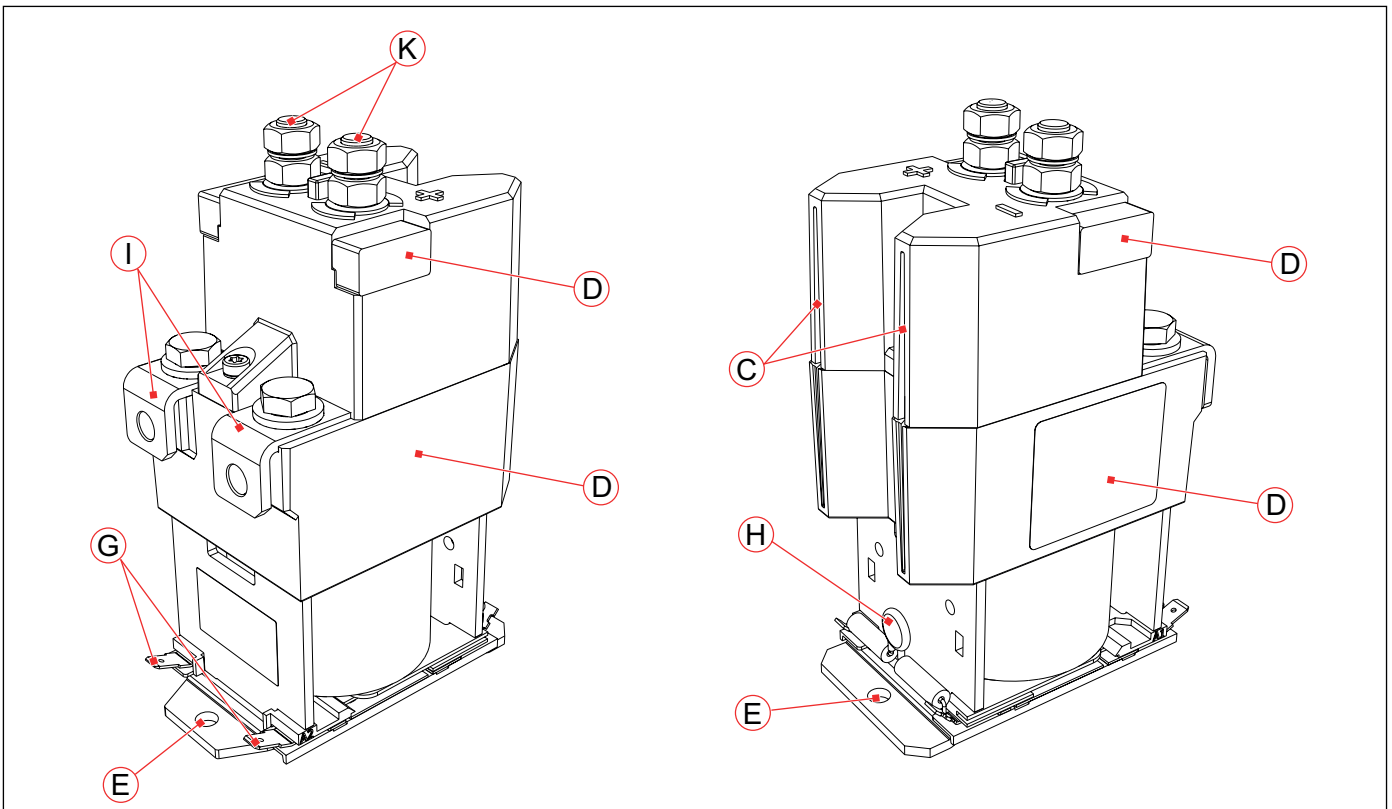

Fig. 8: C195 W/ (left: view from front, right: view from behind)

- C Plasma-exits
- D Permanent magnets (partly inside the housing)
- E Fastening holes for M6 screws
- G Coil terminals A1 and A2, flat plug connections 6.3 x 0.8 mm
- H Coil suppression: Varistor
- I Main contacts NO (normally opened), connection M8, torque: 9.5-12 Nm
- K Main contacts NC (normally closed), connection M8, torque: 4.8-6 Nm

5. Storage

ATTENTION

Moisture and dust can damage the contactors. If the device is to be stored for a prolonged period of time:

- ▶ Store the device in its original packaging,
- ▶ Store the device in a dry and dust-free location

Return shipments

Schaltbau recommends retaining the original packaging for any return shipments.

If the original packaging is not available, care must be taken to pack the contactor in a way that prevents damage during shipment.

6. Unpacking

6.1 Unpacking the device

- ▶ Before opening the packaging, perform a visual inspection for any signs that could indicate damage having occurred during transport (impacts, bumps, dropping, etc.).
- ▶ If any signs indicate that the contactor has been subject to excessive impacts do not install it.

6.2 Check parts for transport damage

ATTENTION

If parts are damaged, functional reliability of the contactor has been lost.

- ▶ Before installing, check all parts for possible transport damage.
- ▶ Do not install damaged parts.

7. Installation

7.1 Mounting

7.1.1 Dimensions/interfaces and further technical specifications

The dimensions and other technical specifications are given in the respective data sheets or can be found in our *B195 catalogue*. The *catalogue* is available under: <https://www.schaltbau.com/en/media-library/>

7.1.2 Preparatory measures

- ▶ A suitable mounting plate or frame must be provided for fastening of the contactors. These must be sufficiently stable to support the weight of the contactors under the expected vibration and shock conditions.
- ▶ Mounting holes must be prepared on the mounting plate or frame according to the following dimensional drawings (Fig. 9 to Fig. 11).

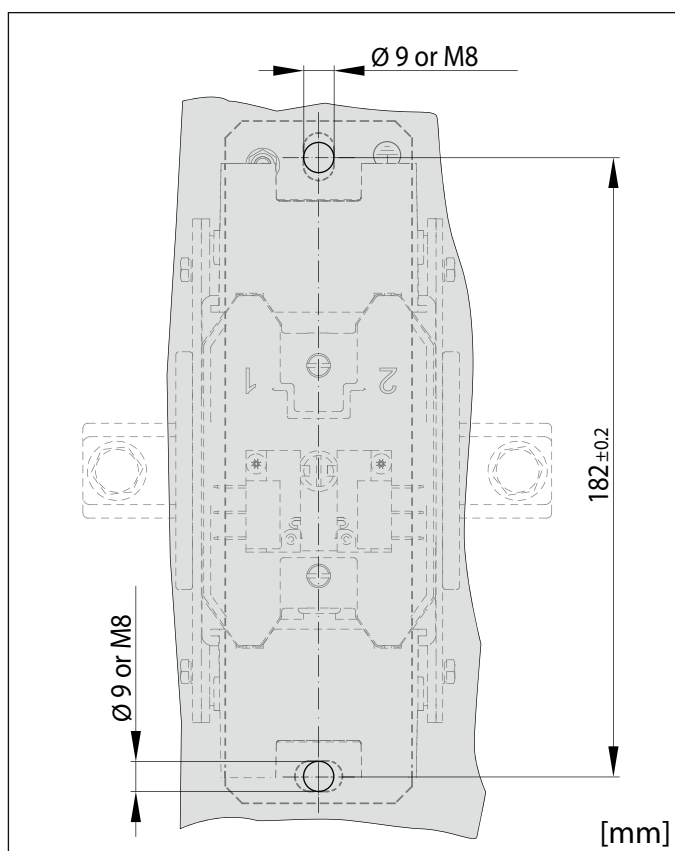

Fig. 9: C195 X:/ Dimensions and layout of mounting holes

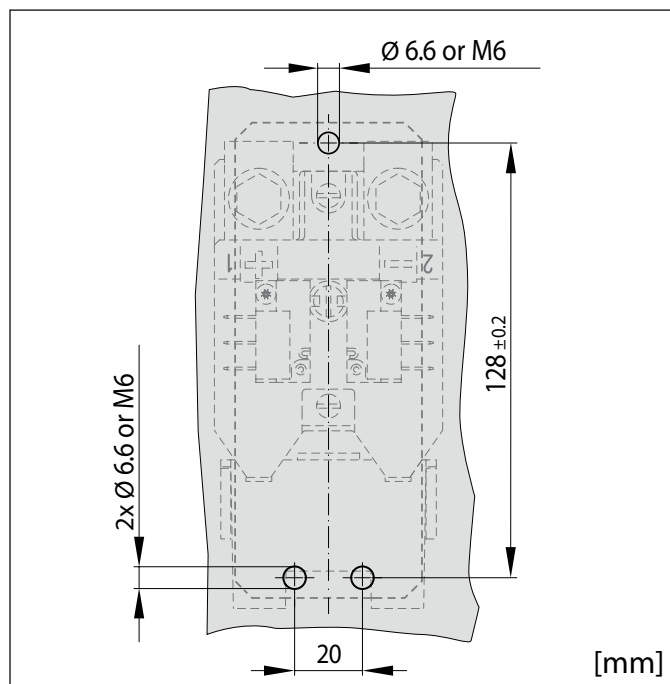

Fig. 10: C195 A/, C195 B/: Dimensions and layout of mounting holes

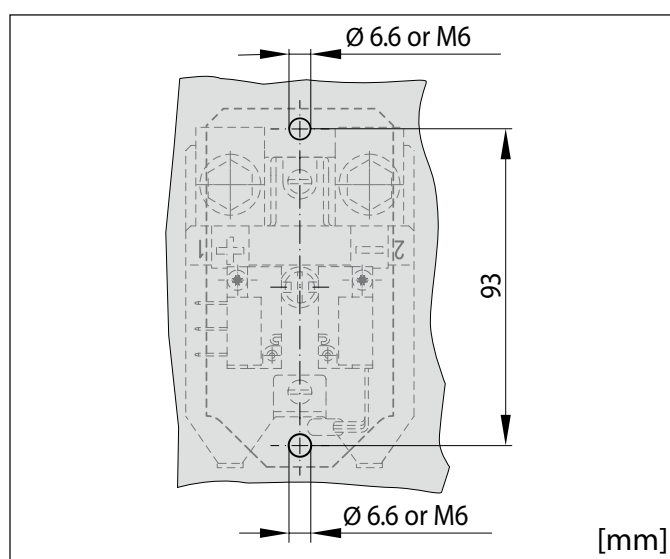

Fig. 11: C195 S/, C195 T/, C195 W/: Dimensions and layout of mounting holes

- ▶ The mounting holes can be either:
 - threaded holes (for threaded screws)
 - or through holes (for threaded screws and nuts)
- ▶ The size and number of mounting screws depending on the type of contactor can be found in the table under “7.1.8 Installing the contactor” on page 20.
- ▶ The length of the mounting screws must be determined dependent on the structural circumstances.

- ▶ To secure the mounting screws so that they do not come loose, appropriate screw locking elements must be provided. Schaltbau recommends using Schnorr washers (or similar).
- ▶ The mounting screws must be tightened to the specified torque, which depends on the strength class (min. 8.8) of the screws/nuts used.

7.1.3 Mounting positions

The contactors can be mounted in almost any position on the prepared mounting plate or on the mounting frame.

Examples of intended installation positions are shown in Fig. 12.

Installation positions hanging, with mounting plate/frame on top, as shown in Fig. 13, are not permissible.

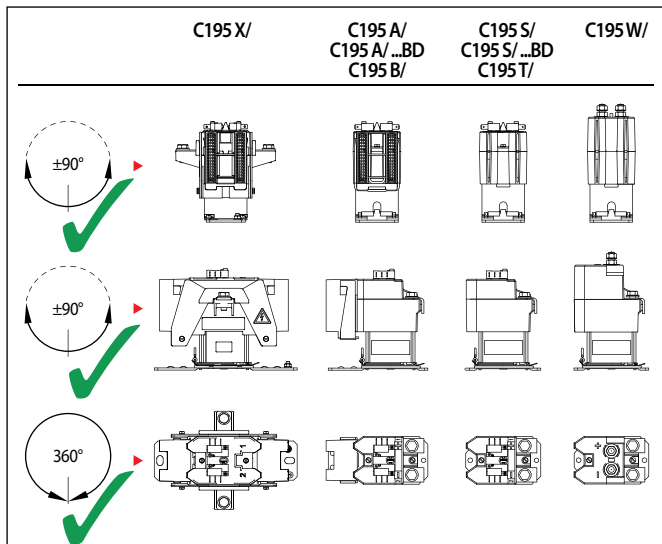

Fig. 12: Examples of intended mounting positions

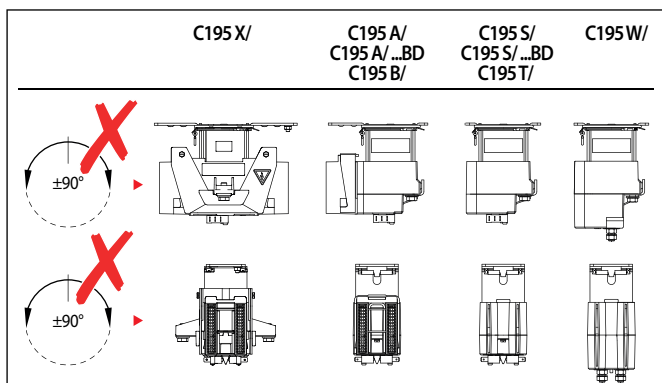

Fig. 13: Examples of non-permissible mounting positions

7.1.4 Required minimum clearances

ATTENTION

Switching of high voltage currents produces electric arcs and it is possible that plasma will escape from the openings of the arc chambers.

Therefore, it is extremely important to maintain the minimum clearances to ground/earth and the bus-bars to avoid flashovers.

- ▶ The required minimum clearances to all sides and above the contactor can be found in our **B195 catalogue**. The **catalogue** is available under: <https://www.schaltbau.com/en/media-library/>

7.1.5 Ventilation requirements

- ▶ Ensure sufficient ventilation in the installation area, especially when switching heavy loads. This allows the plasma to be dissipated more quickly and reduces the risk of flashover and corrosion.

7.1.6 Safety

- ▶ Installation must be performed by qualified trained personnel.

ATTENTION

When installing, ensure that no dirt can get into the contactor as a result of surrounding building activities.

ATTENTION

Detent-edged rings and detent-edged washers have a limited life time. After screws secured with detent-edged rings or detent-edged washers have been undone three times, the rings or washers must be replaced by new ones.

- ▶ Record the frequency of undoing of the screws in the work log.
- ▶ Replace detent-edged rings or detent-edged washers with new ones after the screws have been undone three times.

7.1.7 Tools required

- Socket spanner set, hexagon nuts, set of hexagon socket spanners
- Torque spanner

7.1.8 Installing the contactor

- ▶ Ensure that the contact surfaces on the mounting plate (3) or frame and the bottom of the contactor are free from dirt and other contamination (e.g. metal chips).
- ▶ Position the contactor (1) on the mounting plate/frame (3) which is provided with mounting holes.
- ▶ Screw the contactor (1) on the mounting flange to the mounting plate/frame (3) using mounting screws (2) according to the table below.
 - In designs with the mounting holes implemented as threaded holes, screw the mounting screws into the holes directly, not forgetting the suitable screw locking elements.
 - In designs with through holes, fit the mounting screws and suitable screw locking elements (on both sides) and tighten the screws using nuts.
- ▶ Tighten the mounting screws to the specified torque, which depends on the strength class (min. 8.8) of the screws/nuts used.

Type	Mounting screws	No. of screws
C195 X/	M8	2
C195 A/	M6	3
C195 B/	M6	3
C195 S/	M6	2
C195 T/	M6	2
C195 W/	M6	2

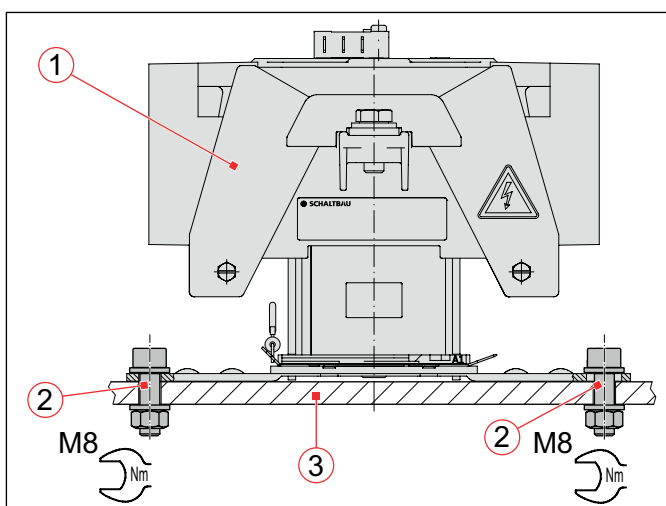

Fig. 14: C195 X/: Installing the contactor on the mounting plate or frame

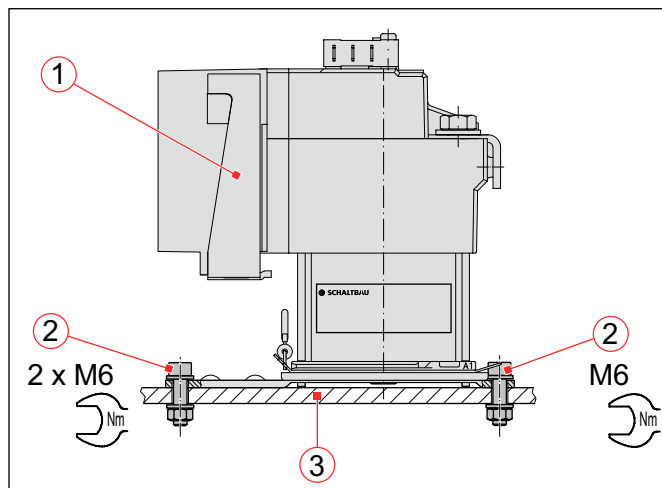

Fig. 15: C195 A/: Installing the contactor on the mounting plate or frame (the figure shows C195 A, the procedure is identical for C195 B/)

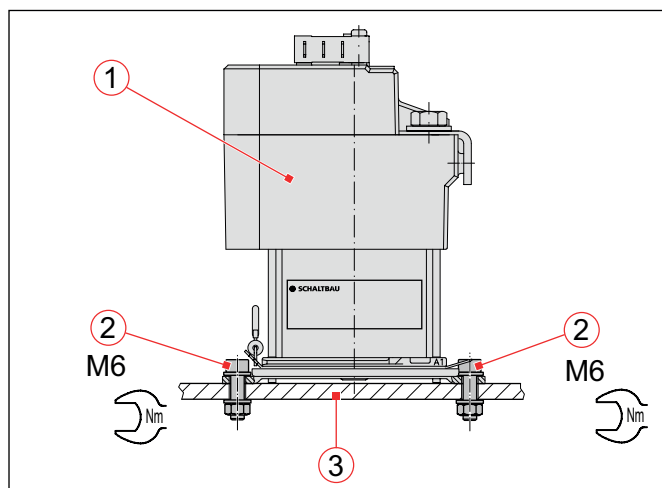

Fig. 16: C195 T/: Installing the contactor on the mounting plate or frame (the figure shows C195 T, the procedure is identical for C195 S/)

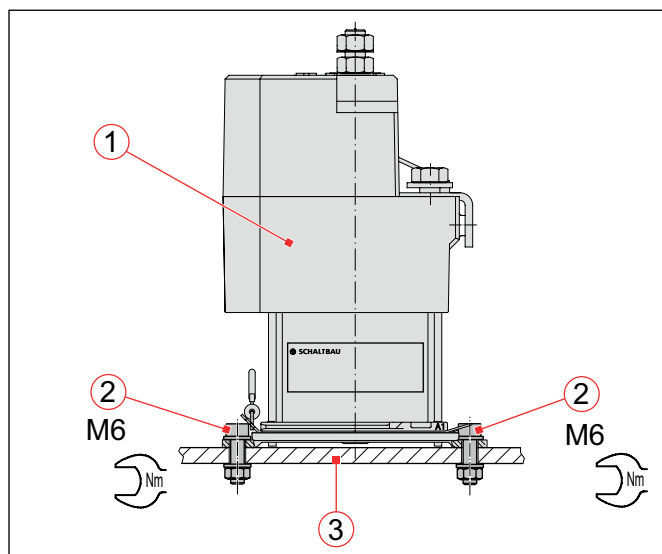

Fig. 17: C195 W/: Installing the contactor on the mounting plate or frame

7.2 Electrical connection

7.2.1 Electrical data and other technical specifications



For the power consumption of the magnetic drive system and electrical data of the auxiliary switches as well as other technical specifications, refer to the respective data sheets and to our *B195 catalogue*. The *catalogue* is available under:

<https://www.schaltbau.com/en/media-library/>

7.2.2 Preparatory measures

- ▶ The minimum conductor cross-sections for the main terminal connection and the earth/ground connection must be observed. Schaltbau recommends busbars for connecting the main contacts.
- ▶ If connecting cables are used, they must be selected taking into consideration the insulation class and ambient conditions..
- ▶ The connecting cables of the main power circuit must be fitted with appropriate ring terminals (for M8 terminal screws).
- ▶ To secure the main terminal screws so that they do not come loose, appropriate screw locking elements must be provided. Schaltbau recommends using Schnorr washers (or similar).
- ▶ The terminal screws must be tightened with the specified torque.
- ▶ Undersized conductor cross-sections for the earth connection may produce a safety hazard.
- ▶ The connections for the coil drive and auxiliary switches are made with flat plugs. Consequently, the control wires must be equipped with corresponding flat receptacles (6.3 x 0.8 mm).
- ▶ The maximum permissible conductor cross-section of the auxiliary switch control wires is 1 mm² / AWG 18 stranded wire.

7.2.3 Safety

 DANGER	
	<p>The contactors are used for high voltage switching. Contact with live electrical parts can result in serious injuries or even death!</p> <p>Live parts are all metal parts belonging directly to one of the circuits or wires connecting to them. All other visible metal parts and wiring may also be live if a fault exists.</p> <p>Before starting any work on the contactors, always comply with the following safety rules:</p>
	<ul style="list-style-type: none">▶ Disconnect on all sides▶ Secure to prevent switching back on▶ Clearly identify the working area▶ Check that a voltage-free state exists▶ Earth and short circuit; this includes discharging any capacitors in the main circuit▶ Besides the main power circuits, also disconnect additional and auxiliary circuits▶ Cover or insulate adjacent live parts▶ The presence of a voltage-free state can only be clearly identified by a qualified electrician.▶ When the work has been concluded, follow the procedure in reverse.

ATTENTION
<p>Detent-edged rings and detent-edged washers have a limited life time. After screws secured with detent-edged rings or detent-edged washers have been undone three times, the rings or washers must be replaced by new ones.</p> <ul style="list-style-type: none">▶ Record the frequency of undoing of the screws in the work log.▶ Replace detent-edged rings or detent-edged washers with new ones after the screws have been undone three times.

7.2.4 Tools required

- Socket spanner set, hexagon nuts
- Open-ended spanner set
- Torque spanner
- Continuity tester
- Cable ties

7.2.5 Connecting the auxiliary switches

The control wires for the auxiliary switches must be fitted with flat receptacles (6.3 x 0.8 mm).

ATTENTION

Make sure that according to the insulation coordination there is sufficient clearance between the wires of the control voltage and the main connections.

ATTENTION

- ▶ The maximum permissible conductor cross-section of the auxiliary switch control wires is 1 mm² / AWG 18 stranded wire.
- ▶ Bending of the connection terminals on the auxiliary switches is not permitted!
- ▶ Move and route the control wires and receptacles only in the direction of plugging, see Fig. 18 to Fig. 20.
- ▶ Mechanically secure the control wires to minimise feedback effects of forces caused by the wires (e. g. shock, vibrations) acting on the terminals.

- ▶ Plug the pre-assembled control wires with the receptacles (1) to the terminals (2) of the auxiliary switches.
- ▶ If applicable bundle and secure the wires using cable ties.

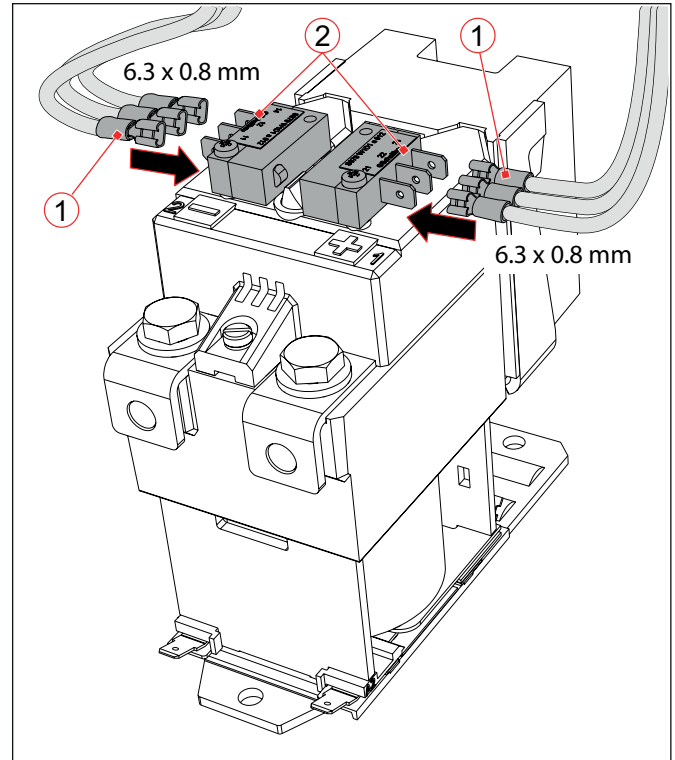

Fig. 19: C195 A/, C195 B/: Connecting the S870 auxiliary switches (the figure shows C195 A/, the procedure is identical for C195 B/)

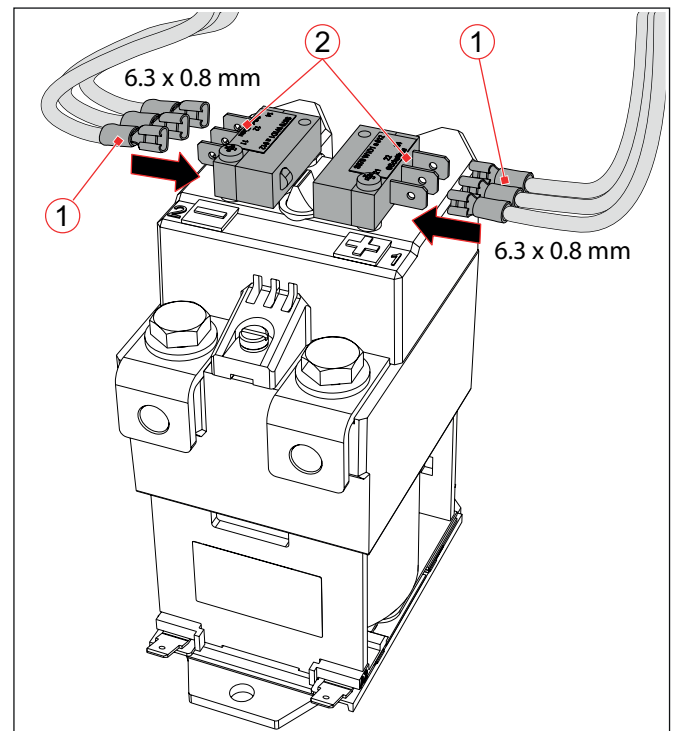

Fig. 20: C195 S/, C195 T/: Connecting the S870 auxiliary switches (the figure shows C195 S/, the procedure is identical for C195 T/)

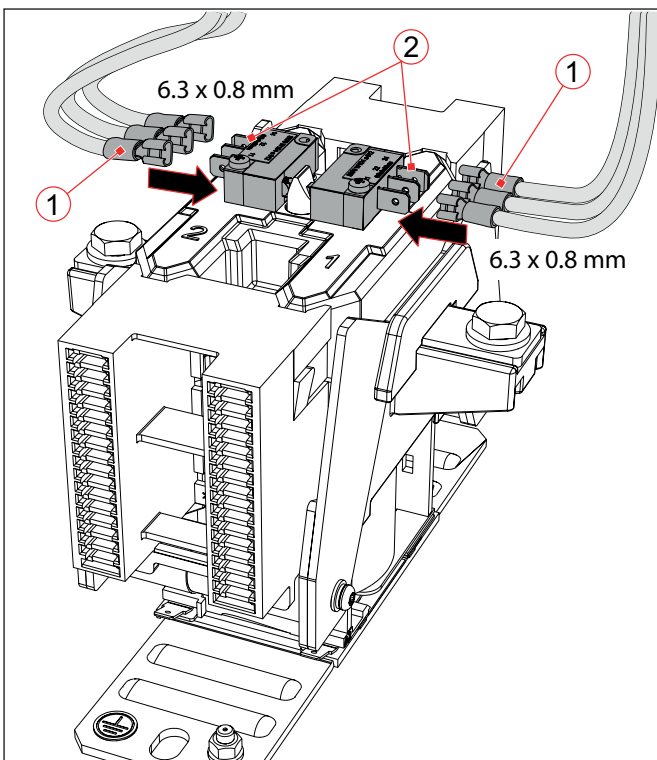

Fig. 18: C195 X/: Connecting the S870 auxiliary switches

Auxiliary switches at latching contactor variants

The latching contactor variants (type C195 A/ ...BD and C195 S/ ...BD) have a hard-wired auxiliary switch (3), which is required to switch over the board for the bi-stable drive. This auxiliary switch (3) is already connected on delivery.

A further S870 auxiliary switch (2) is available for customer use and must be connected if applicable.

- ▶ Plug the pre-assembled control wires with the receptacles (1) to the terminals of the auxiliary switch (2).
- ▶ If applicable bundle and secure the wires using cable ties.

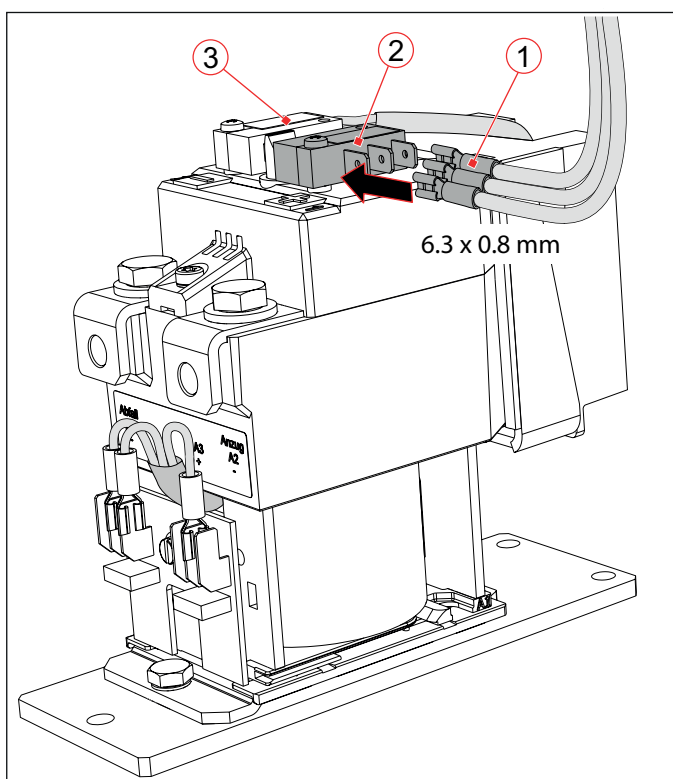

Fig. 21: C195 A/ ...BD latching contactor: Connecting the S870 auxiliary switch

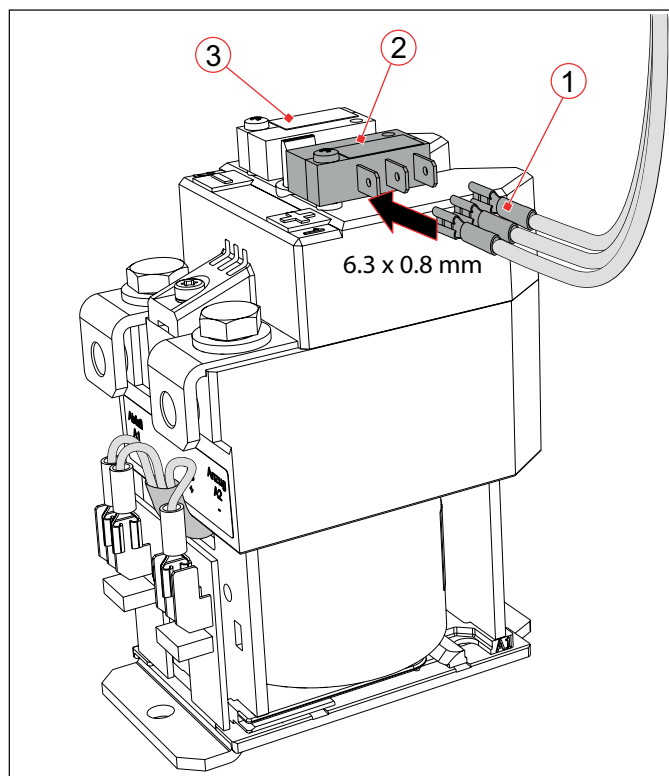

Fig. 22: C195 S/ ...BD, latching contactor: Connecting the S870 auxiliary switch

7.2.6 Connecting the coil

ATTENTION

The value of the overvoltage limitation is part of the magnetic system and must not be modified and in particular not be short-circuited (e.g. by an external diode).

- ▶ Make sure that no such diode is used in your control circuit.

ATTENTION

- ▶ Bending of the coil terminals is not permitted!
- ▶ Move and route the control wires and receptacles only in the direction of plugging, see *Fig. 23 to Fig. 28*.
- ▶ Mechanically secure the control wires to minimise feedback effects of forces caused by the wires (e. g. shock, vibrations) acting on the terminals.

The control wires for the coil terminals must be fitted with flat receptacles (6.3 x 0.8 mm).

- ▶ Plug the pre-assembled control wires with the receptacles (4) to the both coil terminals A1 and A2.
- ▶ If applicable bundle and secure the wires using cable ties.

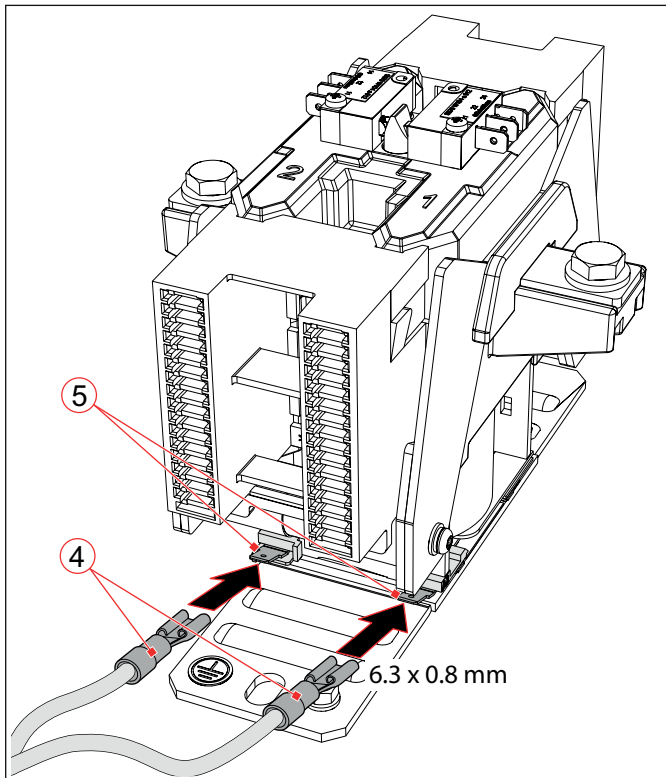

Fig. 23: C195 X/: Connecting the coil

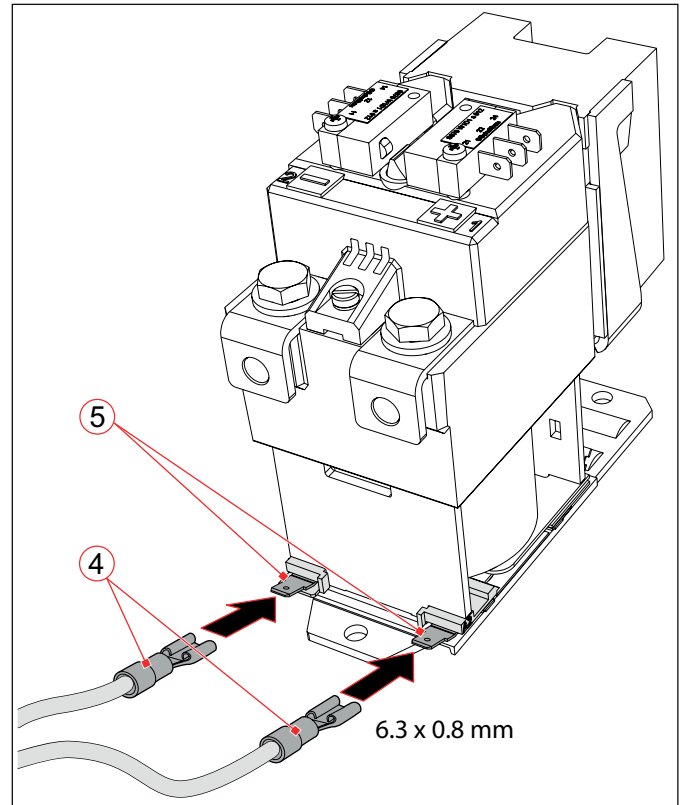

Fig. 24: C195 A/, C195 B/: Connecting the coil (the figure shows C195 A, the procedure is identical for C195 B/)

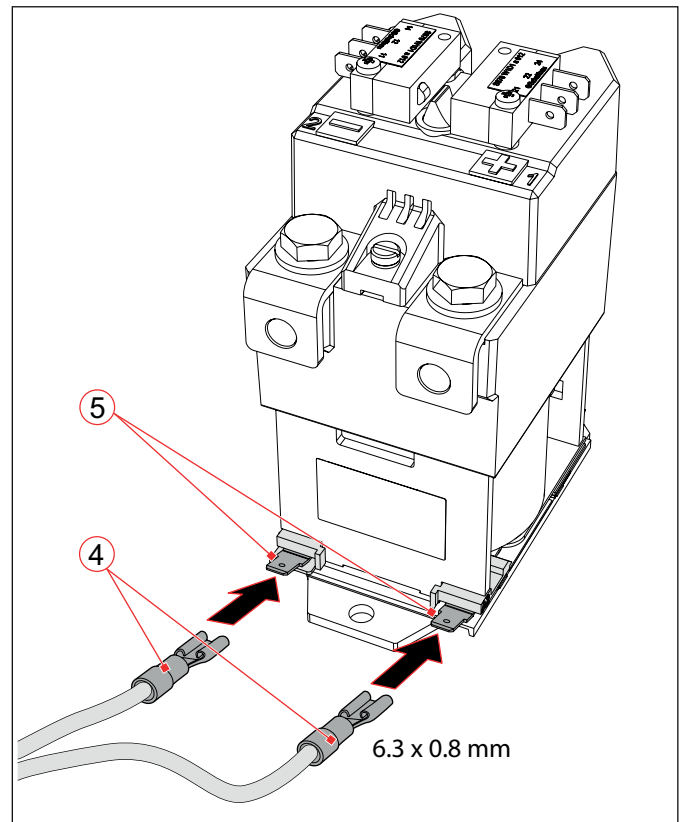

Fig. 25: C195 S/, C195 T/: Connecting the coil (the figure shows C195 S, the procedure is identical for C195 T/)

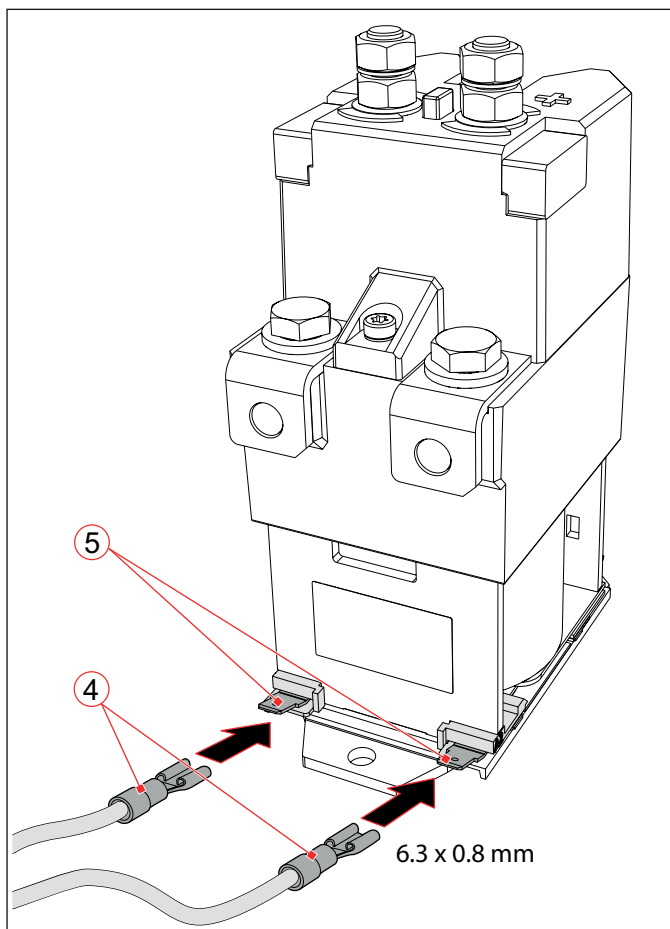

Fig. 26: C195 W/: Connecting the coil

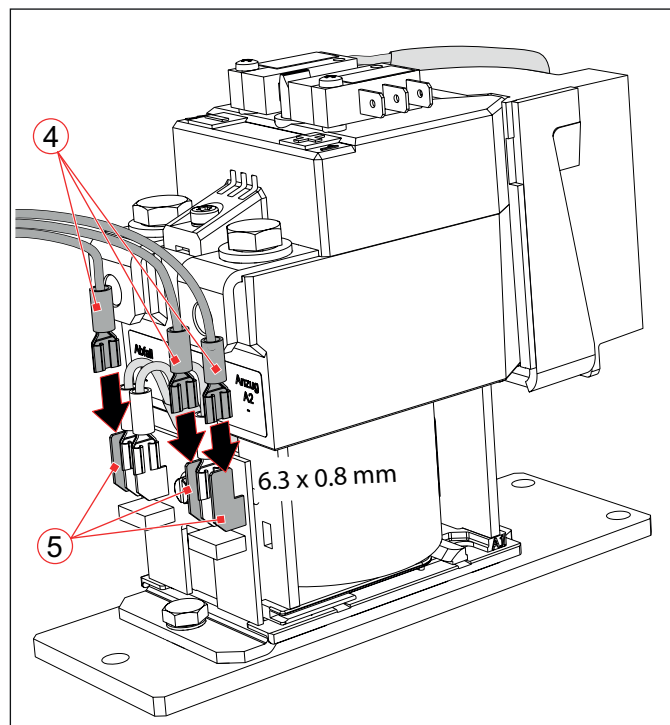

Fig. 27: C195 A/ ...BD latching contactor: Connecting the coil

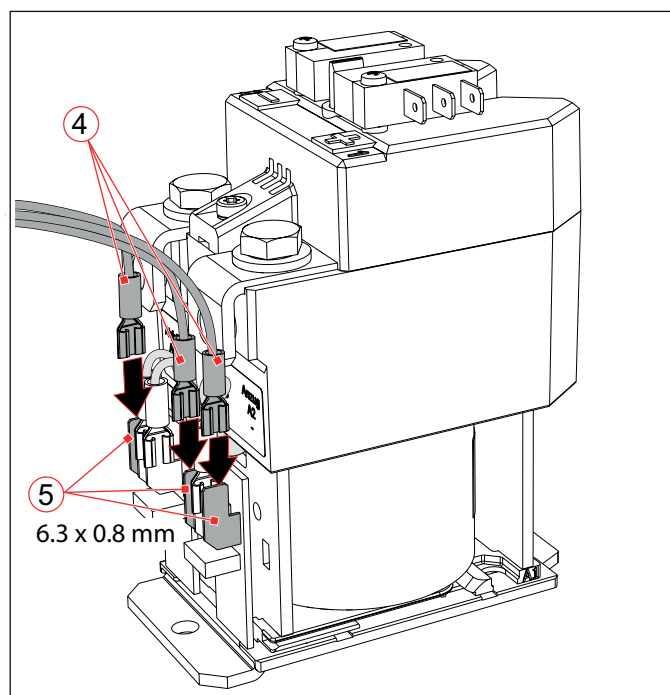

Fig. 28: C195 S/ ...BD latching contactor: Connecting the coil

Coil connections at latching contactor variants

The latching contactor variants (type C195 A/ ...BD and C195 S/ ...BD) have a hard-wired auxiliary switch, which is required to switch over the board for the bistable drive. This auxiliary switch is already connected to the coil terminals A1 and A2 on delivery.

The remaining coil terminals A1, A2 and A3 (5) are available for customer use and must be connected if applicable.

- ▶ Plug the pre-assembled control wires with the receptacles (4) to the coil terminals A1, A2 and A3 (5).
- ▶ If applicable bundle and secure the wires using cable ties.

7.2.7 Connecting the main contacts

ATTENTION
 Ensure that the connection points for the main contacts are free from corrosion.

Main contact connection with cables

The connecting cables of the main power circuit must be fitted with appropriate ring terminals (for M8 terminal screws).

Examples for the connection with cables are shown in Fig. 29 to Fig. 32.

- ▶ Route the pre-assembled connecting cables (3) to the main contacts (1).
- ▶ Place the ring terminals (2) on the main contacts (1).

ATTENTION
 Make sure that according to the insulation class there is sufficient clearance between the main connections and the pole plates.

- ▶ Screw the ring terminals (2) to the main contacts (1) using the terminal screws (4) and washers (5).
 - Schaltbau recommends using Schnorr washers (or similar).
- ▶ Depending on the contactor type, tighten the terminal screws (4) with the prescribed torque according to the table below.

Type	Terminal screws	Torque
C195 X/	M8	8-10 Nm
C195 A/		9.5-12 Nm
C195 B/		9.5-12 Nm
C195 S/		9.5-12 Nm
C195 T/		9.5-12 Nm
C195 W/		9.5-12 Nm (NO contacts) 4.8-6 Nm (NC contacts)

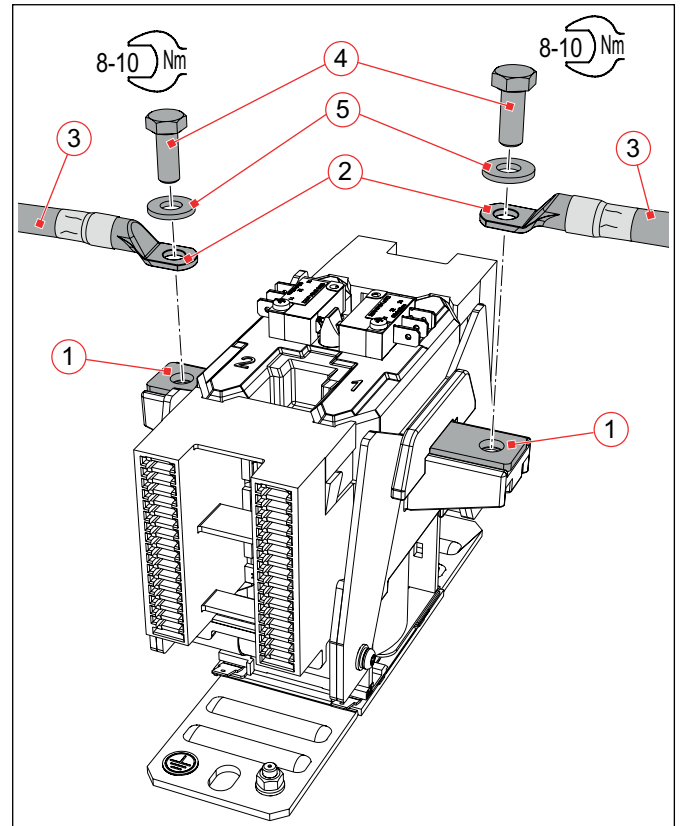

Fig. 29: C195 X/: Connecting the main contacts: Example of a connection with cables

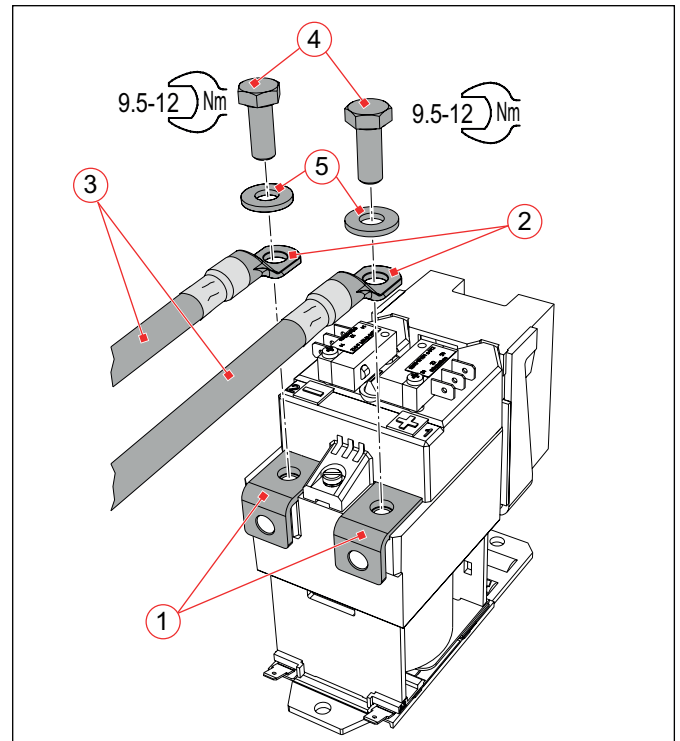

Fig. 30: C195 A/, C195 B/: Connecting the main contacts: Example of a connection with cables (the figure shows C195 A, the procedure is identical for C195 B/)

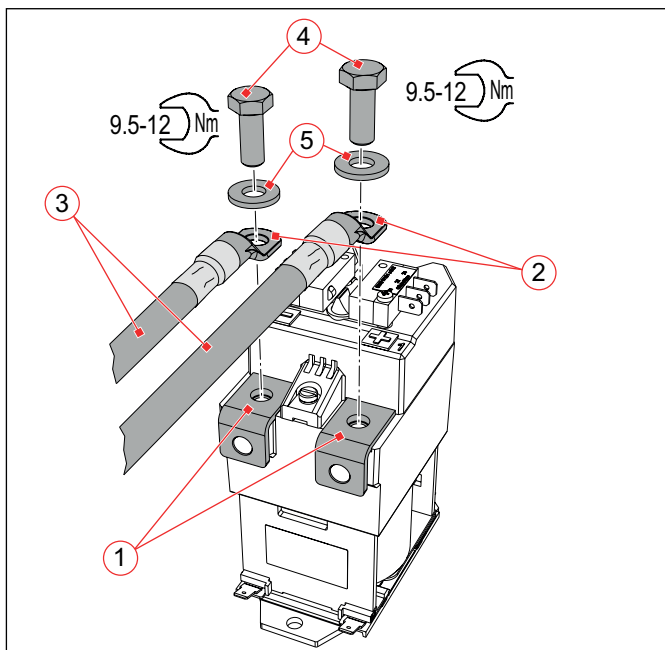

Fig. 31: C195 S/, C195 T/: Connecting the main contacts: Example of a connection with cables (the figure shows C195 S/, the procedure is identical for C195 T/)

Main contact connection with cables (Changeover contactor, only type C195 W/)

Contactors of type C195 W/ (changeover contactor) have 2 upper main contacts (NC) (6) in addition to the lower main contacts (NO) (1).

ATTENTION

Make sure that according to the insulation class there is sufficient clearance between the main connections and the pole plates.

- ▶ Route the pre-assembled connecting cables (7) to the upper main contacts (6).
- ▶ Place the ring terminals (8) on the upper main contacts (6).
- ▶ Screw the ring terminals (8) to the upper main contacts (6) using the terminal nuts (10) and washers (9).
 - Schaltbau recommends using Schnorr washers (or similar).
- ▶ Route the pre-assembled connecting cables (3) to the lower main contacts (1).
- ▶ Place the ring terminals (2) on the lower main contacts (1).
- ▶ Screw the ring terminals (2) to the lower main contacts (1) using the terminal screws (4) and washers (5).
 - Schaltbau recommends using Schnorr washers (or similar).

- ▶ Tighten the upper terminal nuts (10) to a torque of 4.8-6 Nm.
- ▶ Tighten the lower terminal screws (4) to a torque of 9.5-12 Nm.

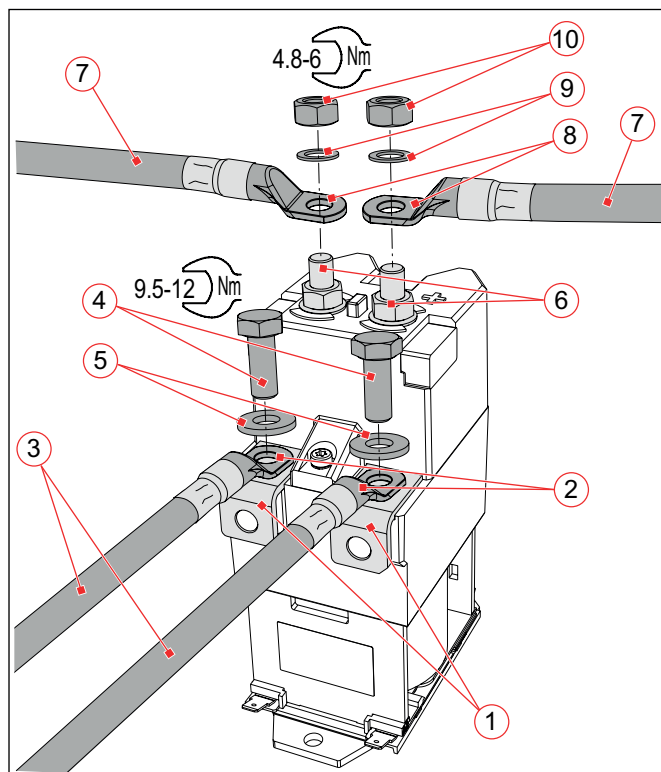

Fig. 32: C195 W/: Connecting the main contacts: Example of a connection with cables to NO and NC contacts

Main contact connection with busbars

As an alternative to connection using wires, the main power circuit can also be connected with busbars. Examples for the connection with busbars are shown in Fig. 33 to Fig. 37.

ATTENTION

Make sure that according to the insulation class there is sufficient clearance between the main connections and the pole plates.

- ▶ Route the busbars (7) to the main contacts (1).
- ▶ Depending on the installation situation, use additional connecting bars (6) or compensating angled connecting bars (8) if necessary.
- ▶ Connect the busbars (7) to the connecting bars (6) or angled connecting bars (8) using appropriate screws, nuts and washers.
 - Schaltbau recommends using Schnorr washers (or similar).
- ▶ Connect the connecting bars (6) or angled connecting bars (8) to the main terminals (1) using the terminal screws (4) and washers (5).
 - Schaltbau recommends using Schnorr washers (or similar).
- ▶ Depending on the contactor type, tighten the terminal screws (4) with the prescribed torque according to the table below.

Type	Terminal screws	Torque
C195 X/	M8	8-10 Nm
C195 A/		9.5-12 Nm
C195 B/		9.5-12 Nm
C195 S/		9.5-12 Nm
C195 T/		9.5-12 Nm
C195 W/		9.5-12 Nm (NO contacts) 4.8-6 Nm (NC contacts)

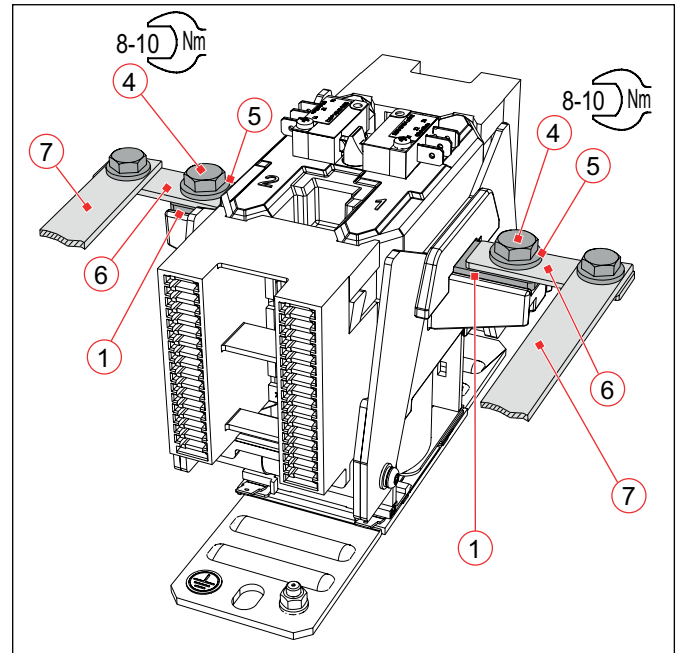

Fig. 33: C195 X/: Connecting the main contacts: Example of a connection with busbars (7) and connecting bars (6)

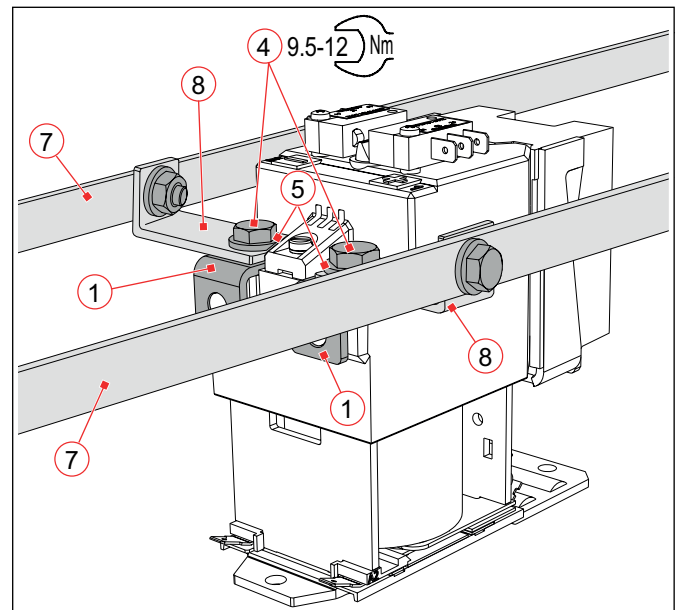

Fig. 34: C195 A/, C195 B/: Connecting the main contacts: Example of a connection with busbars (7) and angled connecting bars (8)

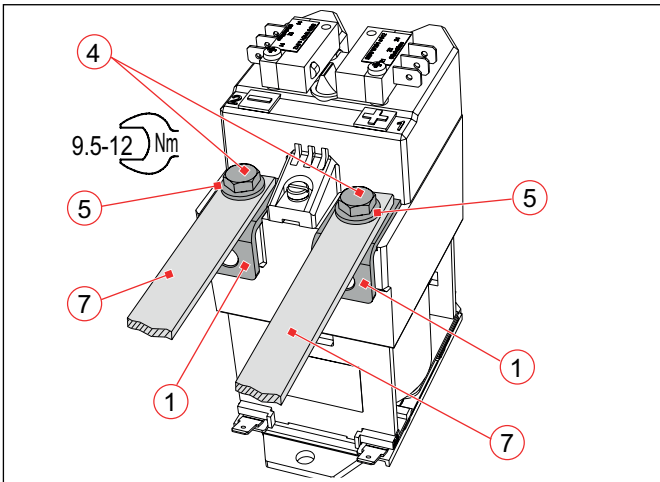

Fig. 35: C195 S/, C195 T/: Connecting the main contacts: Example of a connection with busbars (7)

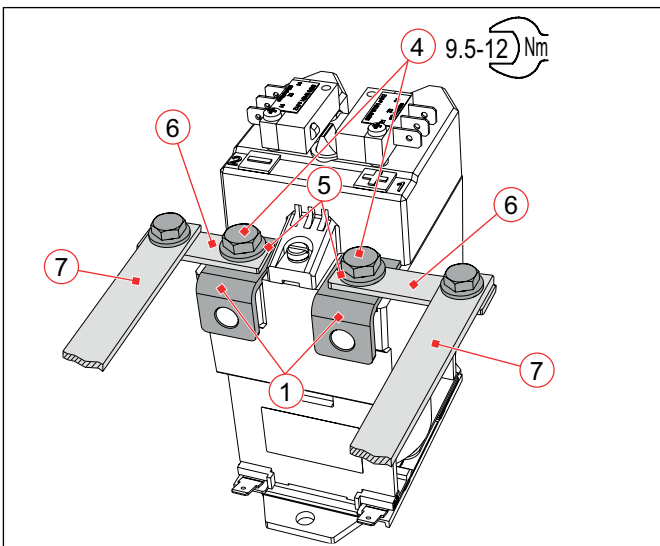

Fig. 36: C195 S/, C195 T/: Connecting the main contacts: Example of a connection with busbars (7) and connecting bars (6)

Main contact connection with busbars (Changeover contactor, only type C195 W/)

Contactors of type C195 W/ (changeover contactor) have 2 upper main contacts (NC) (9) in addition to the lower main contacts (NO) (1).

ATTENTION

Make sure that according to the insulation class there is sufficient clearance between the main connections and the pole plates.

- ▶ Route the busbars (7) to the upper main contacts (9).
- ▶ Depending on the installation situation, use additional connecting bars (6) or compensating angled connecting bars if necessary.

- ▶ Connect the busbars (7) to the connecting bars (6) or angled connecting bars using appropriate screws, nuts and washers.
 - Schaltbau recommends using Schnorr washers (or similar).
- ▶ Connect the connecting bars (6) or angled connecting bars to the upper main terminals (9) using the terminal nuts (10) and washers.
 - Schaltbau recommends using Schnorr washers (or similar).
- ▶ Route the busbars (7) to the lower main contacts (1).
- ▶ Depending on the installation situation, use additional connecting bars (6) or compensating angled connecting bars if necessary.
- ▶ Connect the busbars (7) to the connecting bars (6) or angled connecting bars using appropriate screws, nuts and washers.
 - Schaltbau recommends using Schnorr washers (or similar).
- ▶ Connect the connecting bars (6) or angled connecting bars to the lower main terminals (1) using the terminal screws (4) and washers (5).
 - Schaltbau recommends using Schnorr washers (or similar).
- ▶ Tighten the upper terminal nuts (10) to a torque of 4.8-6 Nm.
- ▶ Tighten the lower terminal screws (4) to a torque of 9.5-12 Nm.

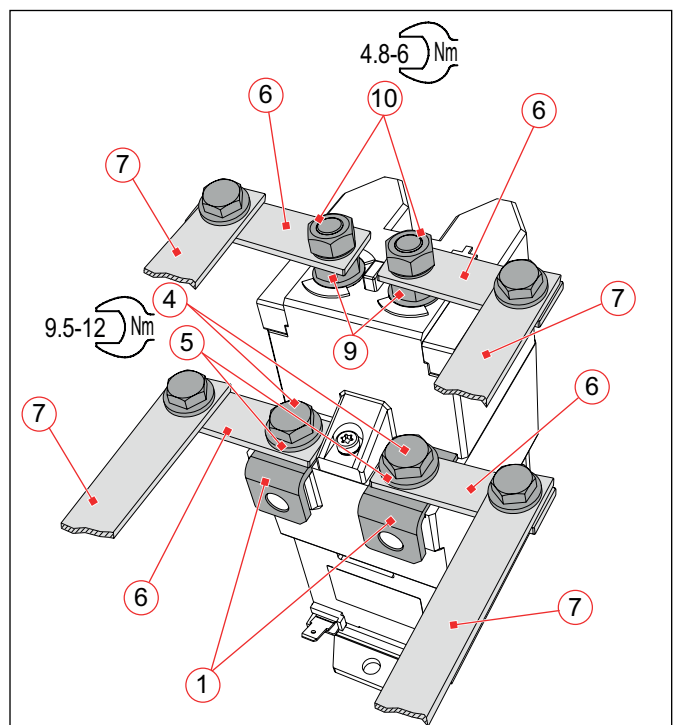

Fig. 37: C195 W/: Connecting the main contacts: Example of a connection with busbars (7) and connecting bars (6) to NO and NC contacts

7.3 Connecting the earth terminal (only for C195 X/)

ATTENTION

Undersized conductor cross-sections for the earth connection may produce a safety hazard.

- ▶ Make sure that the prescribed minimum cross-section for the earth connection is observed.

The earth connecting cable must be fitted with an appropriate ring terminal (for M5 earthing bolt).

- ▶ Route the earth cable (1) to the earthing bolt (2) on the base plate of the contactor.
- ▶ Place the ring terminal (3) on the earthing bolt (2) and screw it on with the M5 terminal nut (5) and washer (4).
- Schaltbau recommends using Schnorr washers (or similar).
- ▶ Tighten the terminal nut (5) to the prescribed torque of 2.4-3 Nm.

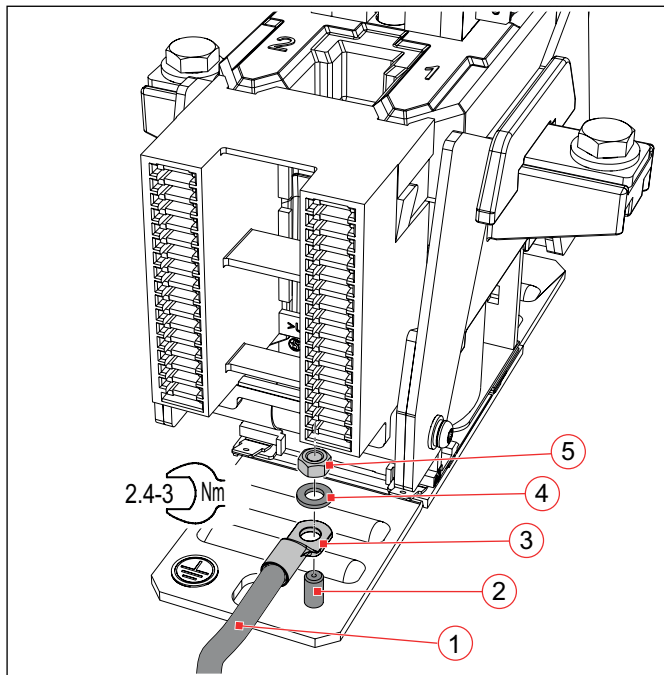

Fig. 38: Connecting the earth terminal (only for C195 X/)

7.4 Checks



After the installation, perform the following checks:

- ▶ Check that the contactors are correctly installed on the mounting plate or mounting frame and tightly screwed in place.
- ▶ Check that the main circuit cables or busbars are correctly installed and fit tightly at the main contacts.
- ▶ Check correct connection and tight fit of the earth cable (only for C195 X/).
- ▶ Check that the control wires of the coil terminals are correctly installed and have the correct polarity.
- ▶ Check that the control wires are correctly connected to the auxiliary switches. Check the correct assignment and function of the auxiliary switch using a continuity tester.
- ▶ Switch the contactor several times without voltage.
- ▶ Check the pull-in and drop-off voltage based on the Schaltbau specifications. See *B195 catalogue*.
- ▶ Check the insulation voltage between earth, coil, main and auxiliary switch contacts.
- ▶ Check the routing of the wiring. Wires must not be squeezed or bent. If applicable bundle and secure wires using cable ties.
- ▶ After every installation or after maintenance, check the contactor for correct operation in accordance with the following standards:
 - EN/IEC 60077-2
 - EN/IEC 60947-4-1

8. Maintenance

Note the expert knowledge which is essential for carrying out maintenance work, referred to in chapter "2. General and safety information".

8.1 Safety

	 DANGER
	<p>The contactors are used for voltage switching. Contact with live electrical parts can result in serious injuries or even death!</p> <p>Live parts are all metal parts belonging directly to one of the circuits or wires connecting to them. All other visible metal parts and wiring may also be live if a fault exists.</p> <p>Before starting any work on the contactors, always comply with the following safety rules:</p> <ul style="list-style-type: none"> ▶ Disconnect on all sides ▶ Secure to prevent switching back on ▶ Clearly identify the working area ▶ Check that a voltage-free state exists ▶ Earth and short circuit; this includes discharging any capacitors in the main circuit ▶ Besides the main power circuits, also disconnect additional and auxiliary circuits ▶ Cover or insulate adjacent live parts ▶ The presence of a voltage-free state can only be clearly identified by a qualified electrician. ▶ When the work has been concluded, follow the procedure in reverse.

8.2 Preventive maintenance

Contactors of the C195 series are maintenance-free within the rated mechanical life time. The electrical life time depends on the number of switching cycles under heavy load conditions and may vary for different applications. In normal use, this corresponds to a decade-long operating period.



8.2.1 Intervals for regular tests/checks

To ensure the correct function and a prolonged operational life span of the contactors, the following tests and checks must be regularly performed.

Test/check	Interval
External visual inspection of the contactor	▶ 1x per year
Check of the main contacts	▶ Every 3 years
Check of the auxiliary switches	▶ Every 3 years

If the contactors are operated in a particularly dirty environment, the visual checks should be performed at shorter intervals. Dirt can impair the clearance and creepage distances, which can result in a shorter service life or to a malfunction.

Unscheduled checks are only required if there have been a significant number of switching operations under short-circuit conditions.

	 DANGER
	<p>If damage to the contactor, cables or busbars is visible during the check, the safety of the contactor is no longer guaranteed.</p> <ul style="list-style-type: none"> ▶ Immediately submit any damaged contactors or components for maintenance.

ATTENTION

Detent-edged rings and detent-edged washers have a limited life time. After screws secured with detent-edged rings or detent-edged washers have been undone three times, the rings or washers must be replaced by new ones.

- ▶ Record the frequency of undoing of the screws in the work log.
- ▶ Replace detent-edged rings or detent-edged washers with new ones after the screws have been undone three times

ATTENTION

When reassembling the old contact unit with the old screws, the operator himself must ensure that the old screws are professionally cleaned and secured.

8.2.2 Regular tests/checks

All of the maintenance activities that may be carried out on the contactors by skilled personnel are listed below.

Component	Tests/checks	Measures
Cables/busbars	Check for: <ul style="list-style-type: none"> ▶ damaged cables, cable lugs ▶ damaged insulation ▶ corrosion ▶ damaged busbars ▶ kinked or crushed cables ▶ loose or missing fastening elements ▶ correct tightening torque of the terminal screw 	In case of faults: <ul style="list-style-type: none"> ▶ immediately replace damaged wires or cable lugs ▶ remove corrosion and replace corroded parts ▶ immediately replace damaged busbars ▶ tighten loose fastening elements immediately, replace missing fastening elements ▶ tighten the terminal screws to the rated torque
Earth terminal (only for C195 X/)	Check for: <ul style="list-style-type: none"> ▶ damaged cable, cable lug ▶ damaged insulation ▶ kinked or crushed cable ▶ loose or missing fastening elements ▶ correct tightening torque of the earth terminal nut ▶ corrosion in the area of the earth connection 	In case of faults: <ul style="list-style-type: none"> ▶ immediately replace damaged wires or cable lugs ▶ tighten loose fastening elements immediately, replace missing fastening elements ▶ tighten the earth terminal nut to the rated torque ▶ remove corrosion in the area of the earth connection
Auxiliary switches	Check for: <ul style="list-style-type: none"> ▶ dirt ▶ damage or wear on the housing ▶ signs of short circuits The auxiliary switches can be accessed from the outside for a simple visual inspection. Under normal working condition (there have been no short circuits in the control circuit) the life time of the auxiliary switches exceeds those of the contactor.	In case of faults: <ul style="list-style-type: none"> ▶ replace the auxiliary switches, see section “8.3.10 Replacing the auxiliary switches – type C195 X/” or “8.4.8 Replacing the auxiliary switches – type C195 A/, B/, S/, T/”

Component	Tests/checks	Measures
<p>Contacting housing</p>	<p>Check for:</p> <ul style="list-style-type: none"> ▶ dirt ▶ damage or heavy wear ▶ penetrations, holes in housing walls ▶ loose or missing fastening elements 	<p>In case of faults:</p> <ul style="list-style-type: none"> ▶ remove any dirt that may be present ▶ in case of damage or heavy wear on the housing, replace the complete contact unit, see <i>"8.3.11 Replacing the complete contact unit – type C195 X/"</i> or <i>"8.4.9 Replacing the complete contact unit – type C195 A/, B/, S/, T/, W/"</i> ▶ if there are holes in the housing walls, replace the complete contact unit, see <i>"8.3.11 Replacing the complete contact unit – type C195 X/"</i> or <i>"8.4.9 Replacing the complete contact unit – type C195 A/, B/, S/, T/, W/"</i> ▶ tighten loose fastening elements immediately replace missing fastening elements ▶ tighten a loose contactor immediately
<p>Magnetic drive</p>	<p>Check for:</p> <ul style="list-style-type: none"> ▶ damage or heavy wear ▶ damage due to operation with impermissible, too high coil voltage 	<p>In case of faults:</p> <ul style="list-style-type: none"> ▶ if damaged or heavily worn, replace the complete magnetic drive unit, see <i>"8.3.13 Replacing the magnetic drive – type C195 X/"</i> or <i>"8.4.11 Replacing the magnetic drive – type C195 A/, B/, S/, T/, W/"</i> on page 57
<p>Arcing chambers (only for C195 X/ C195 A/, C195 A/...BD, C195 B)</p>	<p>Check for:</p> <ul style="list-style-type: none"> ▶ damage or heavy wear ▶ traces of combustion residue (slight soot deposits permitted) 	<p>In case of faults:</p> <ul style="list-style-type: none"> ▶ in case of damage or heavy wear, replace the arcing chambers, see <i>"8.3.14 Replacing the arcing chambers – type C195 X/"</i> or <i>"8.4.12 Replacing the arcing chambers – type C195 A/and C195 B/"</i> on page 57
<p>Complete contact unit</p> <p>Main contacts (both stationary contacts and movable contact bridge)</p>	<p>Prior to checking the main contacts, the cover of the contact unit must first be removed, see section <i>"8.3.7 Removing/attaching the cover – type C195 X/"</i> on page 40 or <i>"8.4.5 Removing/attaching the cover – type C195 A/, B/, S/, T/, W/"</i> on page 53. Thereafter, the main contacts are accessible and can be checked for:</p> <ul style="list-style-type: none"> ▶ damage or wear ▶ traces of combustion residue (slight soot deposits permitted) <p>A certain level of experience is required to assess the state of the contacts. Even after a few load switching cycles, to a lay user the contacts appear worn and the surroundings fouled. Replacement of the complete contact unit is only necessary after more than 70% of the contact material is burnt through (minimum coating height: 0.3 mm, in new condition: 1.2 mm).</p>	<p>In case of faults:</p> <ul style="list-style-type: none"> ▶ if more than 70% of the contact material is burnt through, replace the complete contact unit, see <i>"8.3.11 Replacing the complete contact unit – type C195 X/"</i> or <i>"8.4.9 Replacing the complete contact unit – type C195 A/, B/, S/, T/, W/"</i> ▶ also in case of heavy wear on the housing, replace the complete contact unit, see <i>"8.3.11 Replacing the complete contact unit – type C195 X/"</i> or <i>"8.4.9 Replacing the complete contact unit – type C195 A/, B/, S/, T/, W/"</i>

8.3 Corrective maintenance measures – type C195 X/

The contactors are largely maintenance-free. Therefore there is no general requirement to replace parts during its service life.

However, if an excessive number of emergency shut-downs or damage has occurred during operation, Schaltbau offers original spare parts.

	⚠ WARNING
	<p>The use of non-approved parts can lead to accidents and serious personal injury due to malfunction.</p> <ul style="list-style-type: none"> ▶ Only use original spare parts. ▶ Do not combine individual parts from different contactors!

8.3.1 Preparatory disassembly/assembly steps – type C195 X

	⚠ DANGER
	<p>Before beginning any work on the contactors, make sure that</p> <ul style="list-style-type: none"> ▶ there is no voltage present, ▶ all safety regulations are fully observed. ▶ Be sure to observe section "8.1 Safety" on page 32.

To check the main contacts (stationary and movable contact bridge) and to replace the arcing chambers in the contactors of type C195 X/, the cover of the contactor must be opened. For this purpose, the following preparatory disassembly/assembly steps must be carried out:

- Disassemble/assemble pole packs
- Remove/insert pole plates
- Remove/insert cover
- Remove/insert connecting plate
- Remove/insert contact bridge unit

For easier assembly, the connecting plate and contact bridge unit are removed from the contact unit and later mounted together with the cover.

8.3.2 Disassembling/assembling the pole packs – Typ C195 X/

Tools required

- Set of Torx bits or Torx screwdriver set
- Torque spanner

	⚠ DANGER
	<p>Before beginning any work on the contactors, make sure that</p> <ul style="list-style-type: none"> ▶ there is no voltage present, ▶ all safety regulations are fully observed. ▶ Be sure to observe section "8.1 Safety" on page 32.

Disassembling the pole packs – Typ C195 X/

ATTENTION
<p>Installing the pole packs with wrong magnetic polarity (north pole, south pole) will lead to malfunctions and destruction of the contactor.</p> <ul style="list-style-type: none"> ▶ Before disassembling, note the mounting direction of the pole packs (13) so that they can be re-installed with the correct polarity.

- ▶ Unscrew the 4 screws (14) on the side of the two pole plates (15).
- ▶ Pull the two pole packs (13) off the pole plates (15).

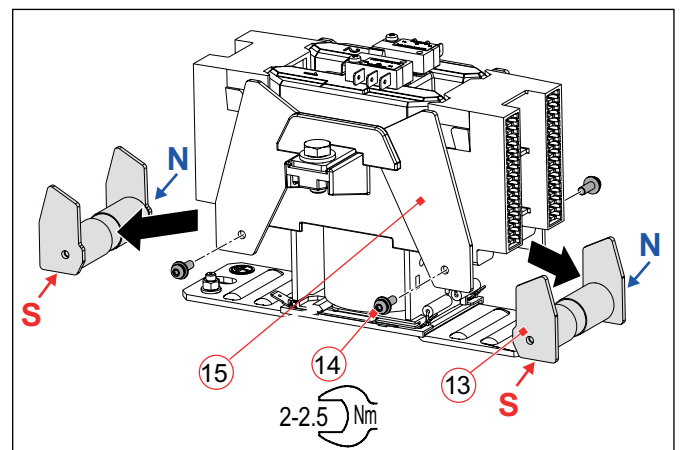

Fig. 39: C195 X/: Disassembling the pole packs

ATTENTION
<p>Do not disassemble the pole packs (13) (pole plate extension/core/permanent magnet) any further because there is a very high risk of positioning the magnetic cores incorrectly.</p>

Assembling the pole packs – Typ C195 X/

ATTENTION

Installing the pole packs (13) with wrong magnetic polarity (north pole, south pole) will lead to malfunctions and destruction of the contactor.

▶ Before installing the pole packs (13), check the previously noted, correct alignment of the magnetic poles, see **Fig. 40**.

▶ Insert the two pole packs (13) one after the other into the pole plates (15) and screw them to the sides of the two pole plates (15) using the 4 screws (14).

▶ Tighten the 4 screws (14) with a torque of 2-2.5 Nm.

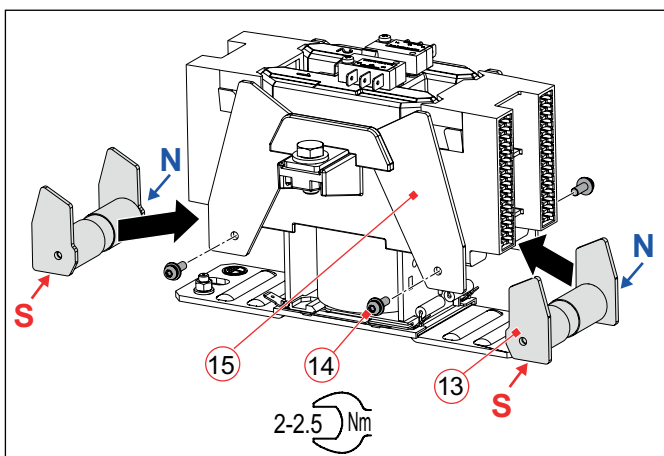

Fig. 40: C195 X/: Assembling the pole packs

8.3.3 Removing/attaching the pole plates – type C195 X/

Requirement

The pole packs are disassembled, see section “8.3.2 Disassembling/assembling the pole packs – Typ C195 X/” on page 35.

Removing the pole plates – type C195 X/

▶ Pull the two pole plates (15) out of the grooves (16) on the cover and remove them upwards.

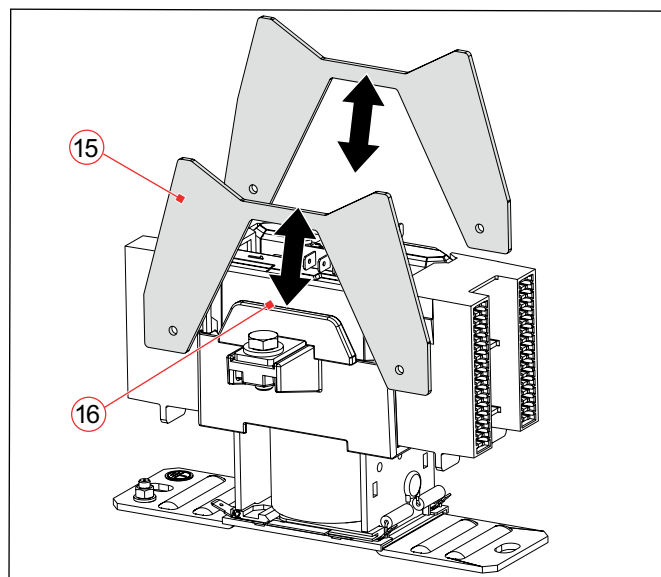

Fig. 41: C195 X/: Removing the pole plates

Attaching the pole plates – type C195 X/

▶ Insert the two pole plates (15) into the grooves (16) on the cover and push them down as far as they will go.

8.3.4 Disassembling/Assembling the auxiliary switches – type C195 X/

Tools required

- Phillips screwdriver set
- Continuity tester
- Torque spanner

	⚠ DANGER
<p>Before beginning any work on the contactors, make sure that</p> <ul style="list-style-type: none"> ▶ there is no voltage present, ▶ all safety regulations are fully observed. ▶ Be sure to observe section "8.1 Safety" on page 32. 	

Disassembling the auxiliary switches – type C195 X/

- ▶ Remove the control wires from the auxiliary switches.
- ▶ Loosen the self-tapping screws (1) on the auxiliary switches (2) and remove them.
- ▶ Remove the auxiliary switches (2) from the contactor top.

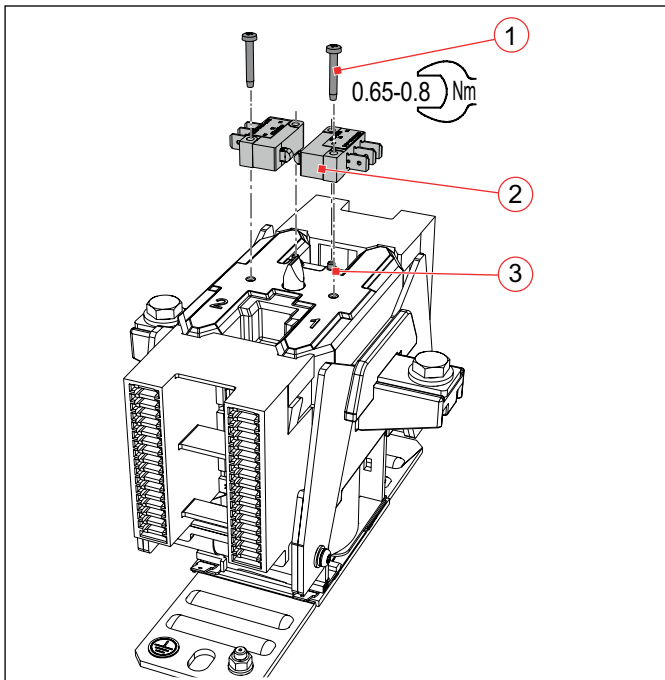

Fig. 42: C195 X/: Disassembling/assembling the auxiliary switches

Assembling the auxiliary switches – type C195 X/

- ▶ Place the auxiliary switches (2) (with printed label facing upwards) so that the locking pin (3) engages in the second hole of the auxiliary switch.
- ▶ Lightly screw on both auxiliary switches (2) with new self-tapping screws (1).
- ▶ If necessary, align the auxiliary switches (2) slightly.
 - The auxiliary switches must switch reliably!
- ▶ Tighten the new self-tapping screws (1) to a torque of 0.65-0.8 Nm.
- ▶ Connect the control wires to the new auxiliary switches (2), see section **"7.2 Electrical connection"/ "7.2.5 Connecting the auxiliary switches" on page 23.**
- ▶ Check the correct connection of the control wires to the auxiliary switches.
- ▶ Use a continuity tester to check the correct assignment and correct function of the auxiliary switches.
- ▶ Finally, subject the contactor to a complete check as described in section **"7.4 Checks" on page 31.**

8.3.5 Disassembling/assembling the contact unit – type C195 X/

Tools required

- Set of Torx bits or Torx screwdriver set
- Continuity tester
- Torque spanner

	⚠ DANGER
	<p>Before beginning any work on the contactors, make sure that</p> <ul style="list-style-type: none"> ▶ there is no voltage present, ▶ all safety regulations are fully observed. ▶ Be sure to observe section "8.1 Safety" on page 32.

Disassembling the contact unit – type C195 X/

- ▶ Remove all connecting cables or busbars from the main contacts, auxiliary switches and coil connections, see section **"7.2 Electrical connection"** on page 21.

ATTENTION
<p>Incorrect installation of the contact unit due to two possible installation positions leads to malfunctions and destruction of the contactor.</p> <ul style="list-style-type: none"> ▶ Before disassembling, note the orientation of the old contact unit in relation to the base plate.

- ▶ Unscrew the 2 screws (1) on the cover (4) of the contactor.
- ▶ Carefully lift the contact unit (2) off the magnetic drive (3).
 - Make sure that the cover (4) does not lift off the housing of the contact unit (2).

	<p>When replacing an old contact unit with a new one, either the old auxiliary switches and the old armature must be transferred to the new complete contact unit or new auxiliary switches and a new armature must be fitted.</p>
---	--

- ▶ If the auxiliary switches from the old contact unit are to be reused, disassemble them. See section **"Disassembling the auxiliary switches – type C195 X/"** on page 37.
- ▶ If the armature is to be reused from the old contact unit, disassemble it. See section **"Disassembling the armature – Typ C195 X/"** on page 39.

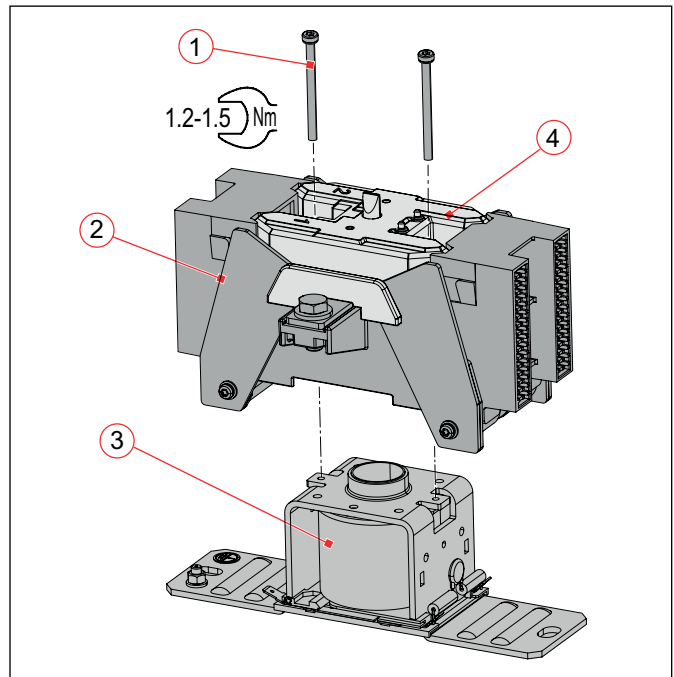

Fig. 43: C195 X/: Disassembling/assembling the contact unit

Assembling the contact unit – type C195 X/

- ▶ If a new complete contact unit is used, mount the existing or a new armature, see section **"Assembling the armature – Typ C195 X/"** on page 39.

ATTENTION
<p>Incorrect installation of the contact unit due to two possible installation positions leads to malfunctions and destruction of the contactor.</p> <ul style="list-style-type: none"> ▶ Before installing the contact unit on the magnetic drive, observe the previously noted correct orientation in relation to the base plate.

- ▶ Carefully place the contact unit (2) with the cover (4) in place on the magnetic drive (3).
 - Make sure that the cover (4) does not lift off the housing of the contact unit (2).

When using a new complete contact unit, new screws (1) with coating for screw securing are included in the scope of delivery. Only use the new screws supplied.

ATTENTION

When reassembling the old contact unit with the old screws, the operator himself must ensure that the old screws are professionally cleaned and secured.

- ▶ Screw the contact unit (2) onto the magnetic drive (3) using the two screws (1) and tighten with a torque of 1.2-1.5 Nm.
- ▶ Check whether the connecting plate (8) is present and correctly positioned; see section *“Attaching the cover – type C195 X/”* on page 40
 - To do this, use a continuity tester to check the electrical connection between the top arcing plates in each case.
 - All 4 arcing plates must have an electrical connection to each other.
- ▶ If a new complete contact unit is used, assemble the existing or new auxiliary switches, see section *“Assembling the auxiliary switches – type C195 X/”* on page 37.
- ▶ Reconnect all connecting cables or busbars (main contacts, auxiliary switches and coil connections), see *“7.2 Electrical connection”* on page 21.
- ▶ Finally, subject the contactor to a complete check as described in section *“7.4 Checks”* on page 31.

8.3.6 Disassembling/assembling the armature – Typ C195 X/

Tools required

- Set of Torx bits or Torx screwdriver set
- Continuity tester
- Torque spanner

Requirement

The contact unit is disassembled, see section *“Disassembling the contact unit – type C195 X/”* on page 38.

Disassembling the armature – Typ C195 X/

- ▶ Pull the armature (5) at the bottom of the contact unit and unhook the armature (5) laterally from the contact bridge unit (6).

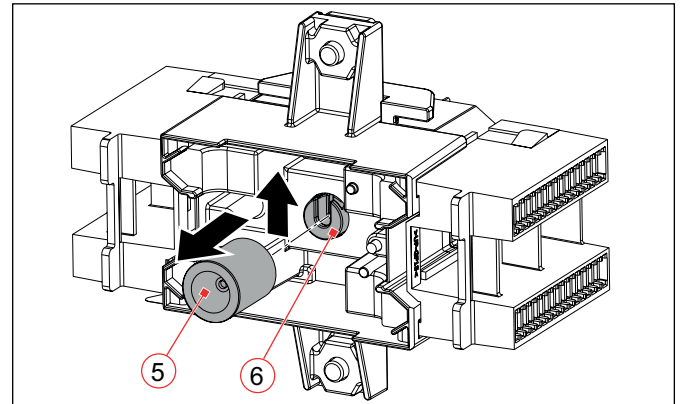

Fig. 44: C195 X/: Disassembling the armature

Assembling the armature – Typ C195 X/

- ▶ Press in the auxiliary switch actuator (7) on the cover (4) and keep it pressed.
 - Make sure that the cover (4) does not lift off the housing of the contact unit (2).
- ▶ With the auxiliary switch actuator (7) pressed, hook the armature (5) laterally into the contact bridge unit (6).

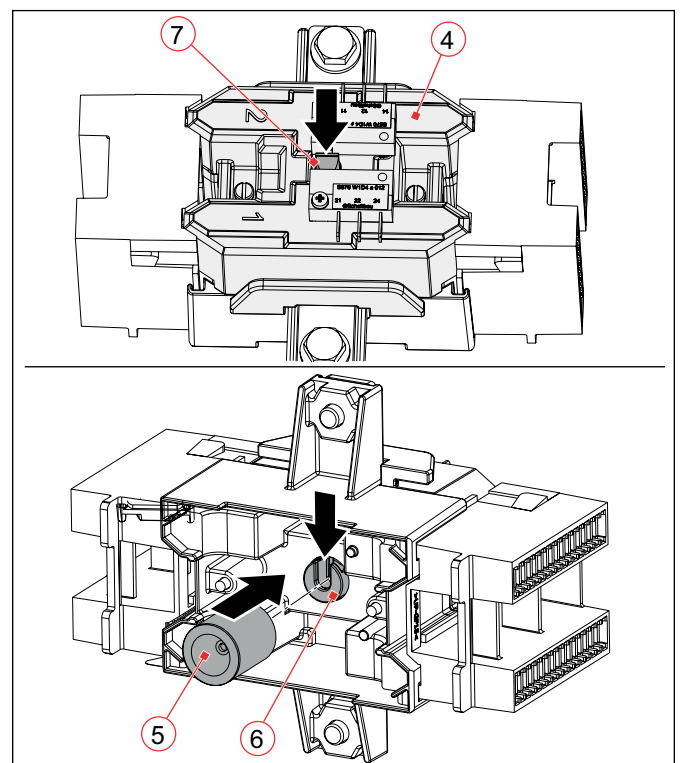



Fig. 45: C195 X/: Assembling the armature

8.3.7 Removing/attaching the cover – type C195 X/

Requirements

- The pole packs are disassembled, see section “Disassembling the pole packs – Typ C195 X/” on page 35.
- The pole plates are removed, see section “Removing the pole plates – type C195 X/” on page 36.
- The contact unit is disassembled, see section “Disassembling the contact unit – type C195 X/” on page 38.
- The armature is disassembled, see section “Disassembling the armature – Typ C195 X/” on page 39.

	<p>⚠ DANGER</p>
	<p>Before beginning any work on the contactors, make sure that</p> <ul style="list-style-type: none"> ▶ there is no voltage present, ▶ all safety regulations are fully observed. ▶ Be sure to observe section “8.1 Safety” on page 32.

Removing the cover – type C195 X/

- ▶ Remove the cover (4) upwards from the contact unit (2).

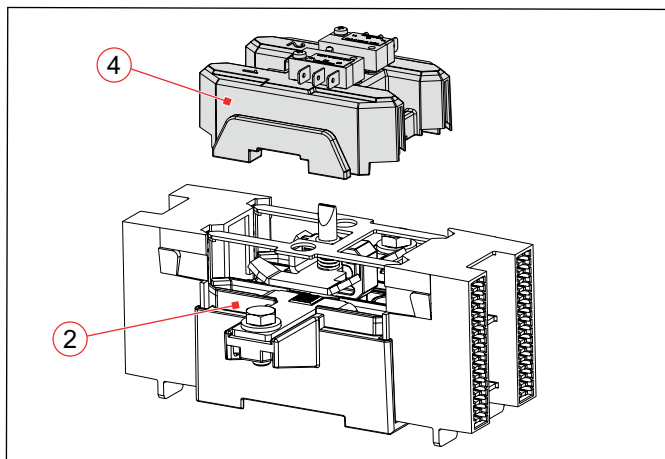

Fig. 46: C195 X/: Removing the cover

For easier assembly, the connecting plate (8) and contact bridge unit (6) are removed from the contact unit (2) and later mounted together with the cover (4).

- ▶ Remove the connecting plate (8) from the contact unit (2).
- ▶ Remove the contact bridge unit (6) from the contact unit (2)

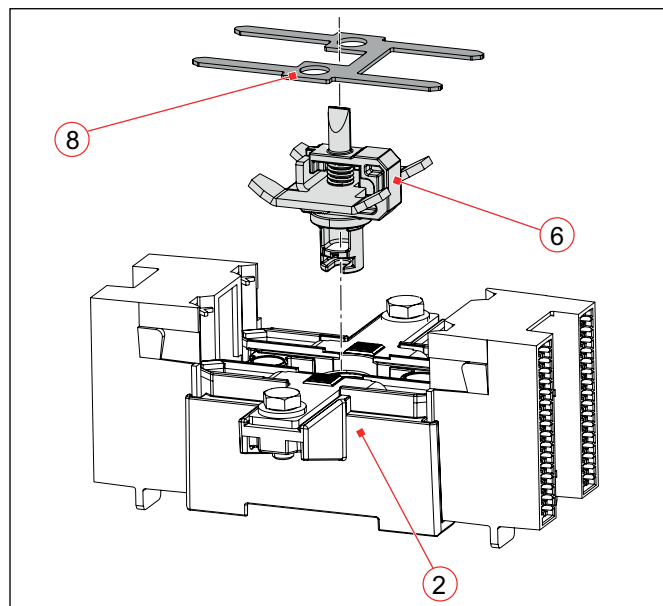

Fig. 47: C195 X/: Removing the connecting plate and contact bridge unit

Attaching the cover – type C195 X/

- ▶ Insert the connecting plate (8) into the cover (2).
- ▶ Insert the contact bridge unit (6) into the cover (2).
 - Make sure that the sealing ring (9) and the contact pressure spring (10) are in place and correctly positioned.

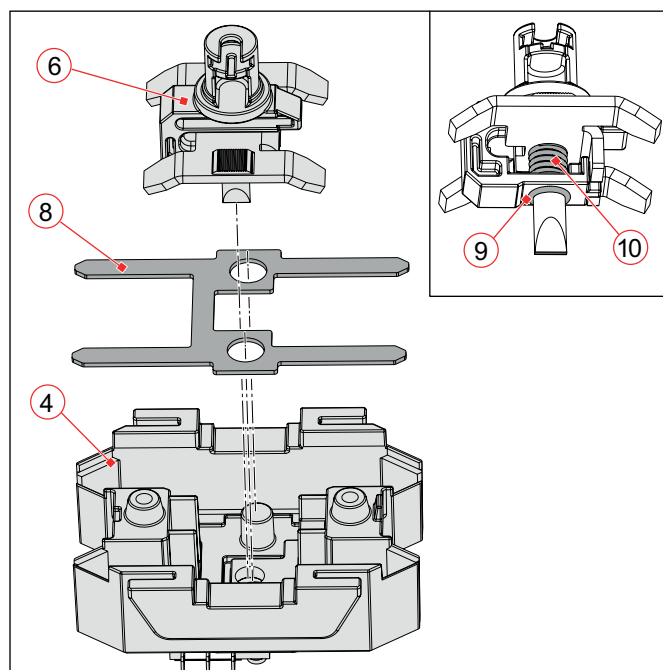

Fig. 48: C195 X/: Insert the connecting plate and contact bridge unit into the cover

- ▶ Grasp the auxiliary switch actuator (7) and hold it firmly so that the position of the connection plate (8) can no longer change.

- ▶ With the auxiliary switch actuator (7) held in place, put the cover (4) on the contact unit (2).
- Make sure that the return spring (11) is in place and correctly positioned.
-

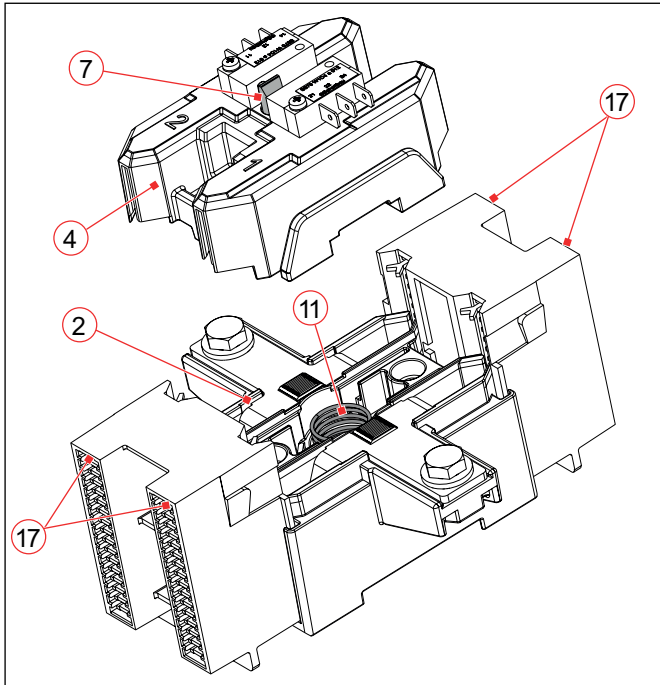



Fig. 49: C195 X/: Place the cover with inserted connecting plate and contact bridge unit on the contact unit

- ▶ Check whether the connecting plate (8) is present and correctly positioned.
- To do this, use a continuity tester to check the electrical connection between the top arcing plates (17) in each case.
- All 4 arcing plates (17) must have an electrical connection to each other.

8.3.8 Disassembling/assembling the magnetic drive – type C195 X/

Tools required

- Set of Torx bits or Torx screwdriver set
- Continuity tester
- Torque spanner

	<p>⚠ DANGER</p>
	<p>Before beginning any work on the contactors, make sure that</p> <ul style="list-style-type: none"> ▶ there is no voltage present, ▶ all safety regulations are fully observed. ▶ Be sure to observe section "8.1 Safety" on page 32.

Disassembling the magnetic drive – type C195 X/

- ▶ Remove all connecting cables or busbars from the main contacts, auxiliary switches and coil connections, see section **"7.2 Electrical connection"** on page 21.

<p>ATTENTION</p>
<p>Incorrect installation of the contact unit due to two possible installation positions leads to malfunctions and destruction of the contactor.</p> <ul style="list-style-type: none"> ▶ Before disassembling, note the orientation of the old contact unit in relation to the base plate.

- ▶ Unscrew the 2 screws (1) on the cover (4) of the contactor.
- ▶ Carefully lift the complete contact unit (2) off the magnetic drive (3).
 - Make sure that the cover (4) does not lift off the housing of the contact unit (2).

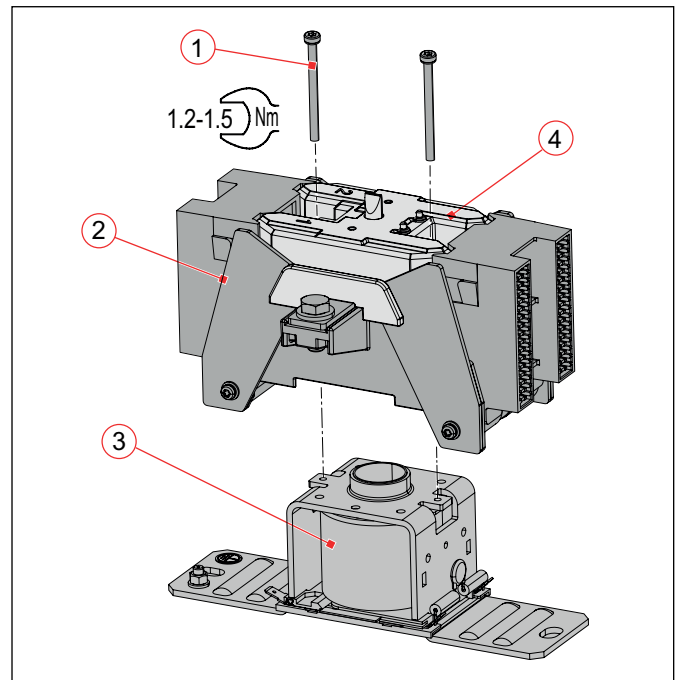

Fig. 50: C195 X/: Disassembling/assembling the magnetic drive

Assembling the magnetic drive – type C195 X/

<p>ATTENTION</p>
<p>Incorrect installation of the contact unit due to two possible installation positions leads to malfunctions and destruction of the contactor.</p> <ul style="list-style-type: none"> ▶ Before installing the contact unit on the magnetic drive, observe the previously noted correct orientation in relation to the base plate.

- ▶ Carefully place the contact unit (2) with the cover (4) in place on the magnetic drive (3).
 - Make sure that the cover (4) does not lift off the housing of the contact unit (2).

When using a new magnetic drive, new screws (1) with coating for screw securing are included in the scope of delivery. Only use the new screws supplied.

<p>ATTENTION</p>
<p>When reassembling the old magnetic drive with the old screws, the operator himself must ensure that the old screws are professionally cleaned and secured.</p>

- ▶ Screw the contact unit (2) onto the magnetic drive (3) using the two screws (1) and tighten with a torque of 1.2-1.5 Nm.

- ▶ Check whether the connecting plate is present and correctly positioned; see section *“Attaching the cover – type C195 X/” on page 40*
 - To do this, use a continuity tester to check the electrical connection between the top arcing plates in each case.
 - All 4 arcing plates must have an electrical connection to each other.
- ▶ Reconnect all connecting cables or busbars (main contacts, auxiliary switches and coil connections), see *“7.2 Electrical connection” on page 21*.
- ▶ Finally, subject the contactor to a complete check as described in section *“7.4 Checks” on page 31*.

8.3.9 Disassembling/assembling the arcing chambers – type C195 X/

Tools required

- Set of Torx bits or Torx screwdriver set
- Continuity tester
- Torque spanner

	⚠ DANGER
	<p>Before beginning any work on the contactors, make sure that</p> <ul style="list-style-type: none"> ▶ there is no voltage present, ▶ all safety regulations are fully observed. ▶ Be sure to observe section <i>“8.1 Safety” on page 32</i>.

Disassembling the arcing chambers – type C195 X/

- ▶ Remove all connecting cables or busbars from the main contacts, auxiliary switches and coil connections, see section *“7.2 Electrical connection” on page 21*.
- ▶ Disassemble the contact unit, see section *“Disassembling the contact unit – type C195 X/” on page 38*.
- ▶ Disassemble the pole packs, see section *“Disassembling the pole packs – Typ C195 X/” on page 35*.
- ▶ Remove the pole plates, see section *“Removing the pole plates – type C195 X/” on page 36*.
- ▶ Remove the cover, see section *“Removing the cover – type C195 X/” on page 40*.

- ▶ Remove the connecting plate, see section *“Removing the cover – type C195 X/” on page 40*.
- ▶ Remove the armature at the bottom of the contact unit, see section *“Disassembling the armature – Typ C195 X/” on page 39*.
- ▶ Disassemble the contact bridge unit, see section *“Removing the cover – type C195 X/” on page 40*.
- ▶ Hold the lower part of the contact unit (2) and pull out both arcing chambers (12) upwards one after the other.

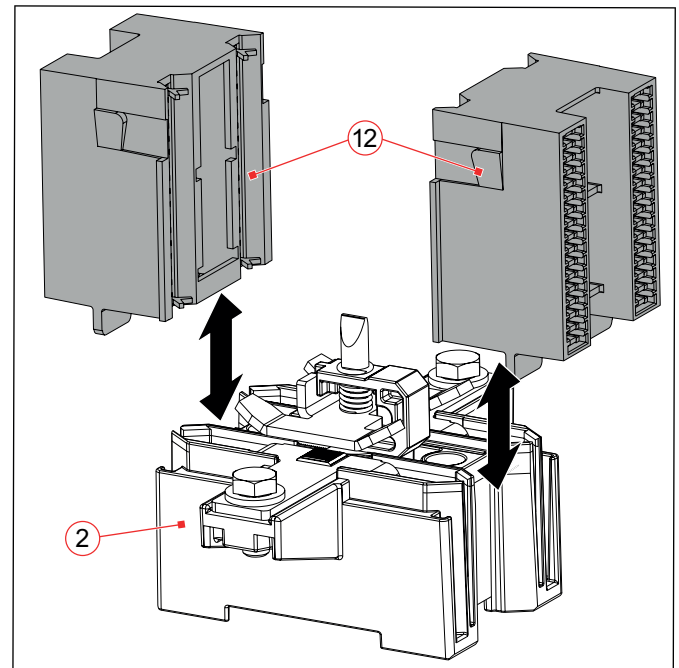

Fig. 51: C195 X/: Removing/attaching the arcing chambers

Assembling the arcing chambers – type C195 X/

- ▶ Push the two new arcing chambers (12) into the contact unit (2) one after the other as far as they will go.
- ▶ Insert the connecting plate and contact bridge unit into the cover and, with the auxiliary switch actuator held in place, place the cover on the contact unit. See section *„Attaching the cover – type C195 X/” on page 40*.
- ▶ Install the armature at the bottom side of the contact unit. See section *„Assembling the armature – Typ C195 X/” on page 39*.
- ▶ Screw the contact unit (2) with the cover in place onto the magnetic drive (3) using the two screws (1) and tighten with a torque of 1.2-1.5 Nm, see section *“Assembling the contact unit – type C195 X/” on page 38*.

- ▶ Check whether the connecting plate is present and correctly positioned, see section ***“Attaching the cover – type C195 X/” on page 40.***
 - To do this, use a continuity tester to check the electrical connection between the top arcing plates in each case.
 - All 4 arcing plates must have an electrical connection to each other.
- ▶ Insert the 2 pole plates. See section ***“Attaching the pole plates – type C195 X/” on page 36.***
- ▶ Assemble the 2 pole packs. See section ***“Assembling the pole packs – Typ C195 X/” on page 36.***
- ▶ Reconnect all connecting cables or busbars (main contacts, auxiliary switches and coil connections), see ***“7.2 Electrical connection” on page 21.***
- ▶ Finally, subject the contactor to a complete check as described in section ***“7.4 Checks” on page 31.***

8.3.10 Replacing the auxiliary switches – type C195 X/

Under normal working condition (there have been no short circuits in the control circuit) the life time of the auxiliary switches exceeds those of the contactor. However, in the event of a short circuit in the control circuit, it is possible that the auxiliary switches may be damaged and need to be replaced.

Spare parts required

Auxiliary switch assembly (2 auxiliary switches with self-tapping screws), see chapter “9. Spare parts”.

Procedure

- ▶ For the procedure for replacing the auxiliary switches, see section “8.3.4 Disassembling/Assembling the auxiliary switches – type C195 X/” on page 37.
- ▶ Finally, subject the contactor to a complete check as described in section “7.4 Checks” on page 31

8.3.11 Replacing the complete contact unit – type C195 X/

Spare parts required

Contact unit complete (housing with contact bridge unit, main contacts, arcing chambers complete and blowout unit with permanent magnets) see chapter “9. Spare parts”.

Procedure

- ▶ For the procedure for replacing the contact unit, see section “8.3.5 Disassembling/assembling the contact unit – type C195 X/” on page 38.
- ▶ Finally, subject the contactor to a complete check as described in section “7.4 Checks” on page 31 and in section “8.3.5 Disassembling/assembling the contact unit – type C195 X/” on page 38.

8.3.12 Replacing the armature – type C195 X/

Spare parts required

Armature according to the type of contactor. See chapter “9. Spare parts”.

Procedure

- ▶ For the procedure for replacing the armature see section “8.3.6 Disassembling/assembling the armature – Typ C195 X/” on page 39.

- ▶ Finally, subject the contactor to a complete check as described in section “7.4 Checks” on page 31 and in section “8.3.5 Disassembling/assembling the contact unit – type C195 X/” on page 38.

8.3.13 Replacing the magnetic drive – type C195 X/

Spare parts required

Magnetic drive with preset coil voltage depending on the type of contactor. See chapter “9. Spare parts”.

Procedure

- ▶ For the procedure for replacing the magnetic drive see section “8.3.8 Disassembling/assembling the magnetic drive – type C195 X/” on page 42.
- ▶ Finally, subject the contactor to a complete check as described in section “7.4 Checks” on page 31 and in section “8.3.5 Disassembling/assembling the contact unit – type C195 X/” on page 38.

8.3.14 Replacing the arcing chambers – type C195 X/

Spare parts required

Arcing chambers complete (arcing chambers with arcing plates), see chapter “9. Spare parts”.

Procedure

- ▶ For the procedure for replacing the arcing chambers see section “8.3.9 Disassembling/assembling the arcing chambers – type C195 X/” on page 43.
- ▶ Finally, subject the contactor to a complete check as described in section “7.4 Checks” on page 31 and in section “8.3.5 Disassembling/assembling the contact unit – type C195 X/” on page 38.

8.4 Corrective maintenance measures – type C195 A/, B/, S/, T/, W/

The contactors are largely maintenance-free. Therefore there is no general requirement to replace parts during its service life.

However, if an excessive number of emergency shut-downs or damage has occurred during operation, Schaltbau offers original spare parts.

	⚠ WARNING
	<p>The use of non-approved parts can lead to accidents and serious personal injury due to malfunction.</p> <ul style="list-style-type: none"> ▶ Only use original spare parts. ▶ Do not combine individual parts from different contactors!

8.4.1 Preparatory disassembly/assembly steps – type C195 A/, B/, S/, T/, W/

	⚠ DANGER
	<p>Before beginning any work on the contactors, make sure that</p> <ul style="list-style-type: none"> ▶ there is no voltage present, ▶ all safety regulations are fully observed. ▶ Be sure to observe section "8.1 Safety" on page 32.

- To check the main contacts (stationary and movable contact bridge) (for type C195 A/, B/, S/, T/, W/) and to replace the arcing chamber (only for types C195 A/ and B/), the cover of the contactor must be opened. See section **"8.4.5 Removing/attaching the cover – type C195 A/, B/, S/, T/, W/"** on page 53.
- To replace the armature, the complete contact unit must be dismantled. See section **"8.4.3 Disassembling/assembling the contact unit – type C195 A/, B/, S/, T/, W/"** on page 49.

8.4.2 Disassembling/Assembling the auxiliary switches – type C195 A/, B/, S/, T/

Tools required

- Phillips screwdriver set
- Continuity tester
- Torque spanner

Disassembling the auxiliary switches – type C195 A/, B/, S/, T/

	⚠ DANGER
	<p>Before beginning any work on the contactors, make sure that</p> <ul style="list-style-type: none"> ▶ there is no voltage present, ▶ all safety regulations are fully observed. ▶ Be sure to observe section "8.1 Safety" on page 32.

- ▶ Remove the control wires from the auxiliary switches.
- ▶ Loosen the self-tapping screws (1) on the auxiliary switches (2) and remove them.
- ▶ Remove the auxiliary switches (2) from the contactor top.

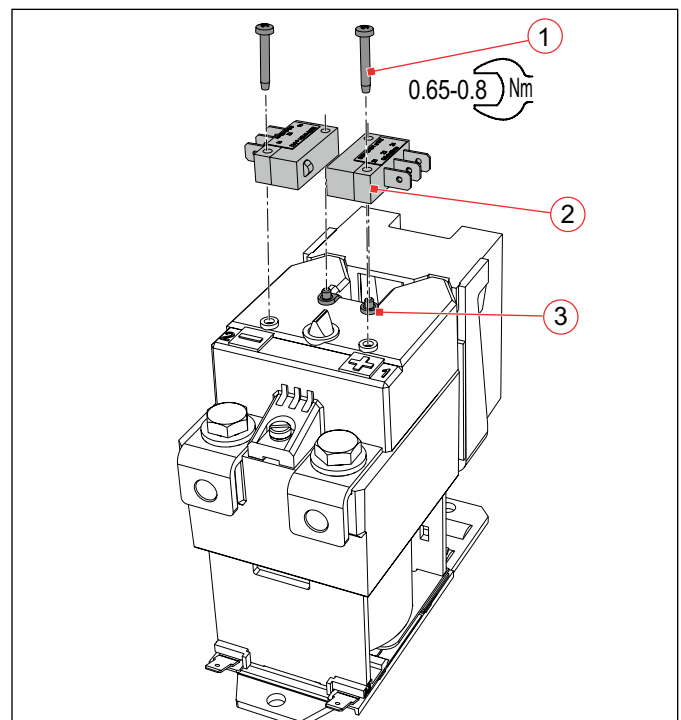

Fig. 52: C195 A/, C195 B/: Replacing the auxiliary switches (the figure shows C195 A/, the procedure is identical for C195 B/)

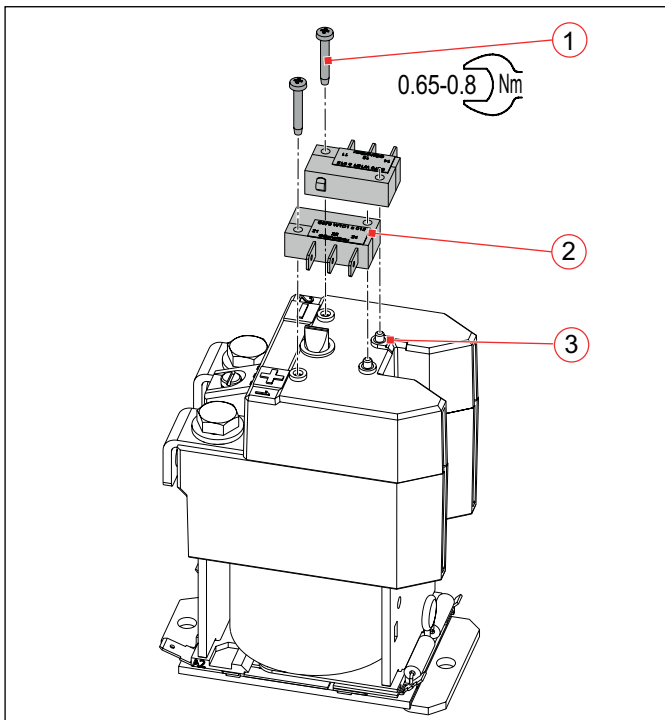

Fig. 53: C195 S/, C195 T/: Replacing the auxiliary switches (the figure shows C195 S/, the procedure is identical for C195 T/)

Assembling the auxiliary switches – type C195 A/, B/, S/, T/

- ▶ Place new auxiliary switches (2) (with printed label facing upwards) so that the locking pin (3) engages in the second hole of the auxiliary switch.
- ▶ Lightly screw on both auxiliary switches (2) with new self-tapping screws (1).
- ▶ If necessary, align the auxiliary switches (2) slightly.
 - The auxiliary switches must switch reliably!
- ▶ Tighten the new self-tapping screws (1) with a torque of 0.65-0.8 Nm.
- ▶ Connect the control wires to the new auxiliary switches (2), see section “7.2 Electrical connection”/ “7.2.5 Connecting the auxiliary switches” on page 23.
- ▶ Check the correct connection of the control wires to the auxiliary switches.
- ▶ Use a continuity tester to check the correct assignment and correct function of the auxiliary switches.
- ▶ Finally, subject the contactor to a complete check as described in section “7.4 Checks” on page 31.

Auxiliary switches for latching contactor types (C195 A/ ...BD und C195 S/ ...BD)



The latching versions (type C195 A/ ...BD and C195 S/ ...BD) have a hard-wired auxiliary switch (4) which is required for switching over the circuit board for the latching drive. This auxiliary switch (4) is not intended for replacement by the customer!

One further S870 auxiliary switch (2) is available for customer use. This auxiliary switch (2) can be replaced if necessary.

- ▶ The procedure for replacing the single auxiliary switch (2) is the same as described in section “8.4.2 Disassembling/Assembling the auxiliary switches – type C195 A/, B/, S/, T/” on page 46, but only the customer usable auxiliary switch (2) is replaced instead of 2 auxiliary switches.

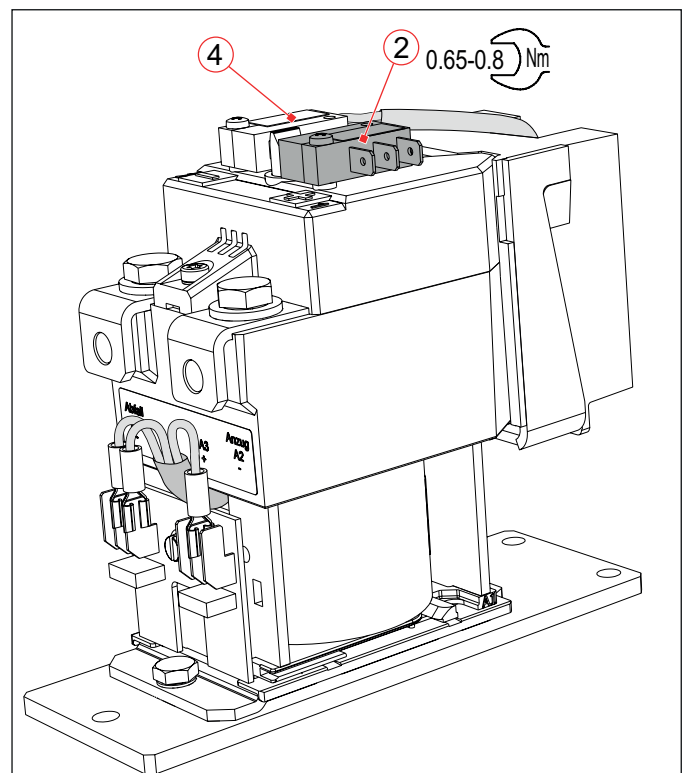

Fig. 54: C195 A/ ...BD, latching version: replace the single auxiliary switch S870 (2)

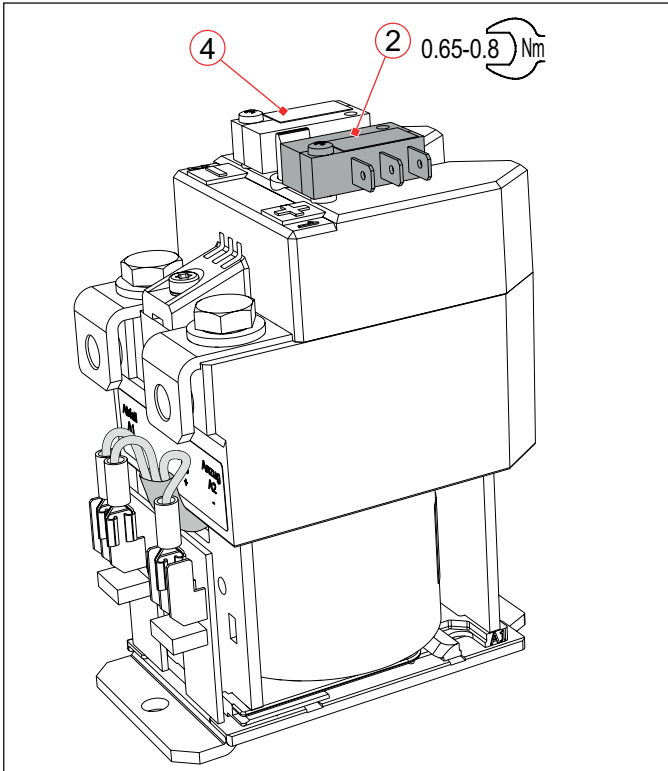



Fig. 55: C195 S/...BD, latching version: replace the single auxiliary switch S870 (2)

8.4.3 Disassembling/assembling the contact unit – type C195 A/, B/, S/, T/, W/

Tools required

- Set of Torx bits or Torx screwdriver set
- Continuity tester
- Torque spanner

	<p>⚠ DANGER</p>
	<p>Before beginning any work on the contactors, make sure that</p> <ul style="list-style-type: none"> ▶ there is no voltage present, ▶ all safety regulations are fully observed. ▶ Be sure to observe section "8.1 Safety" on page 32.

Disassembling the contact unit – type C195 A/, B/, S/, T/, W/

- ▶ Remove all connecting cables or busbars from the main contacts, auxiliary switches and coil connections, see section **"7.2 Electrical connection"** on page 21.

<p>ATTENTION</p>
<p>Incorrect installation of the contact unit due to two possible installation positions leads to malfunctions and destruction of the contactor.</p> <ul style="list-style-type: none"> ▶ Before disassembling, note the orientation of the contact unit in relation to the base plate

- ▶ Unscrew the 2 screws (1) on the cover (4) of the contactor.
- ▶ Carefully lift the contact unit (2) off the magnetic drive (3).
 - Make sure that the cover (4) does not lift off the housing of the contact unit (2).

	<p>When replacing an old contact unit with a new one, either the old auxiliary switches and the old armature must be transferred to the new complete contact unit or new auxiliary switches and a new armature must be fitted.</p>
---	--

- ▶ If the auxiliary switches from the old contact unit are to be reused, disassemble them. See section **"8.4.2 Disassembling/Assembling the auxiliary switches – type C195 A/, B/, S/, T/"** on page 46.

- ▶ If the armature is to be reused from the old contact unit, disassemble it. See section **"Disassembling the armature – type C195 A/, B/, S/, T/, W/"** on page 51.

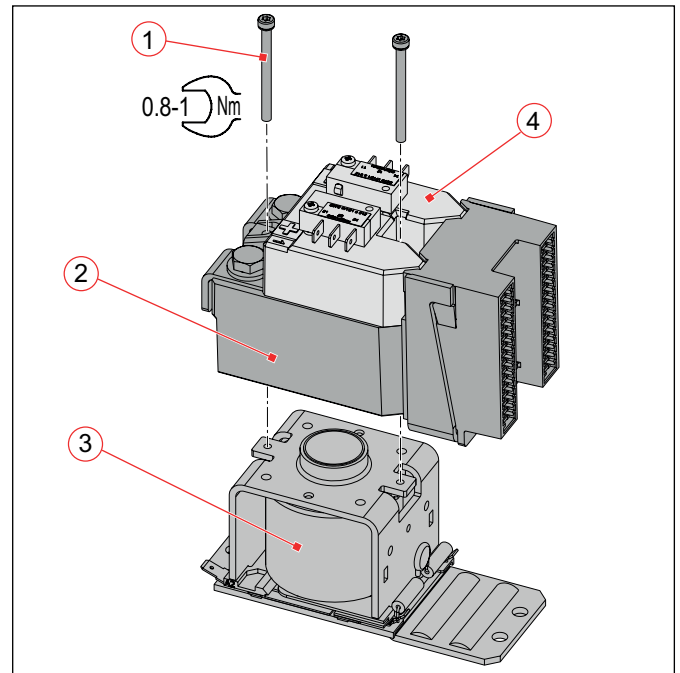

Fig. 56: C195 A/, C195 B/: Disassembling/assembling the contact unit (the figure shows C195 A/, the procedure is identical for C195 B/)

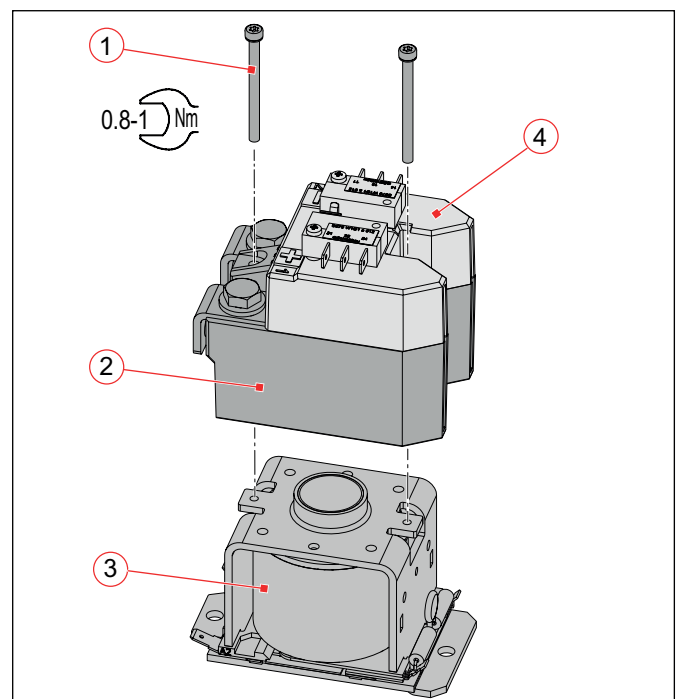

Fig. 57: C195 S/, C195 T/: Disassembling/assembling the contact unit (the figure shows C195 S/, the procedure is identical for C195 T/)

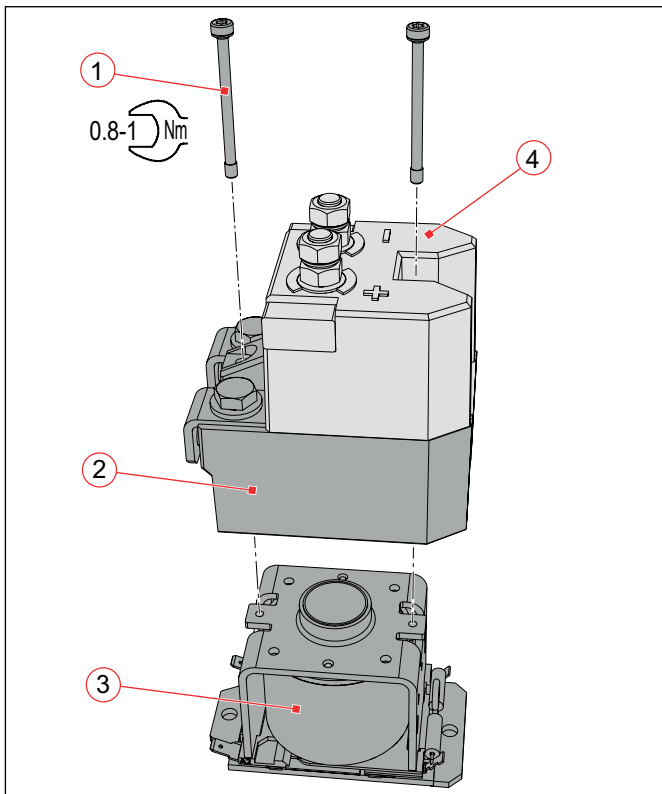

Fig. 58: C195 W/: Disassembling/assembling the contact unit

Assembling the contact unit – type C195 A/, B/, S/, T/, W/

- ▶ If a new complete contact unit is used, mount the existing or a new armature, see section “*Assembling the armature – type C195 A/, B/, S/, T/, W/*” on page 51.

ATTENTION

Incorrect installation of the contact unit due to two possible installation positions leads to malfunctions and destruction of the contactor.

- ▶ Before installing the contact unit on the magnetic drive, observe the previously noted correct orientation in relation to the base plate.
- ▶ Carefully place the contact unit (2) on the magnetic drive (3).
 - Make sure that the cover (4) does not lift off the housing of the contact unit (2).

When using a new complete contact unit, new screws with coating for screw securing are included in the scope of delivery. Only use the new screws supplied.

ATTENTION

When reassembling the old contact unit with the old screws, the operator himself must ensure that the old screws are professionally cleaned and secured.

- ▶ Screw the contact unit (2) onto the magnetic drive (3) using the two screws (1) and tighten it with a torque of 0,8-1 Nm.
- ▶ If a new complete contact unit is used, assemble the existing or new auxiliary switches, see section “*Assembling the auxiliary switches – type C195 A/, B/, S/, T/*” on page 47.
- ▶ Reconnect all connecting cables or busbars (main contacts, auxiliary switches and coil connections), see “*7.2 Electrical connection*” on page 21.
- ▶ Finally, subject the contactor to a complete check as described in section “*7.4 Checks*” on page 31.

8.4.4 Disassembling/assembling the armature – type C195 A/, B/, S/, T/, W/

Requirement

The contact unit is disassembled, see section “8.4.3 Disassembling/assembling the contact unit – type C195 A/, B/, S/, T/, W/” on page 49.

Disassembling the armature – type C195 A/, B/, S/, T/, W/

- ▶ Pull the armature (5) at the bottom of the contact unit and unhook the armature (5) laterally from the contact bridge unit (6).

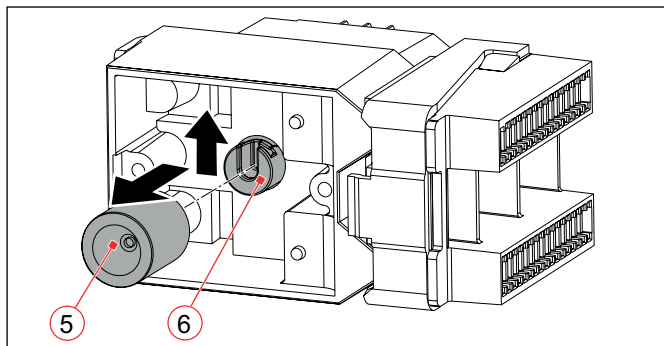

Fig. 59: C195 A/, C195 B/: Disassembling the armature (the figure shows C195 A/, the procedure is identical for C195 B/)

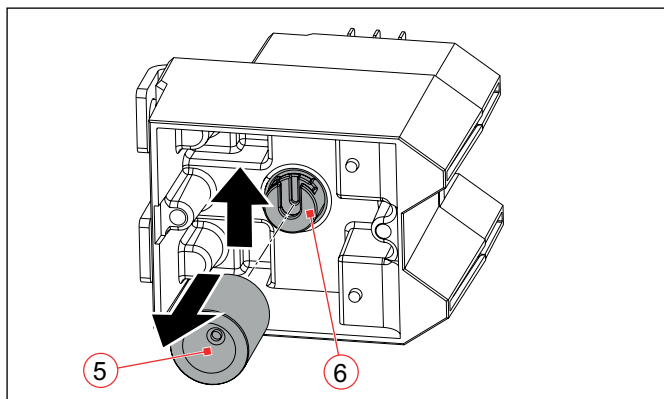

Fig. 60: C195 S/, C195 T/: Disassembling the armature (the figure shows C195 S/, the procedure is identical for C195 T/)

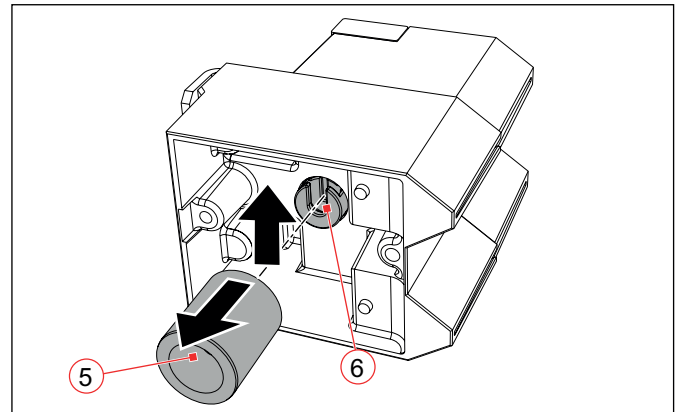

Fig. 61: C195 W/: Disassembling the armature

Assembling the armature – type C195 A/, B/, S/, T/, W/

- ▶ Press in the auxiliary switch actuator (7) on the cover (4) and keep it pressed.
- ▶ With the auxiliary switch actuator (7) pressed, hook the armature (5) laterally into the contact bridge unit (6).

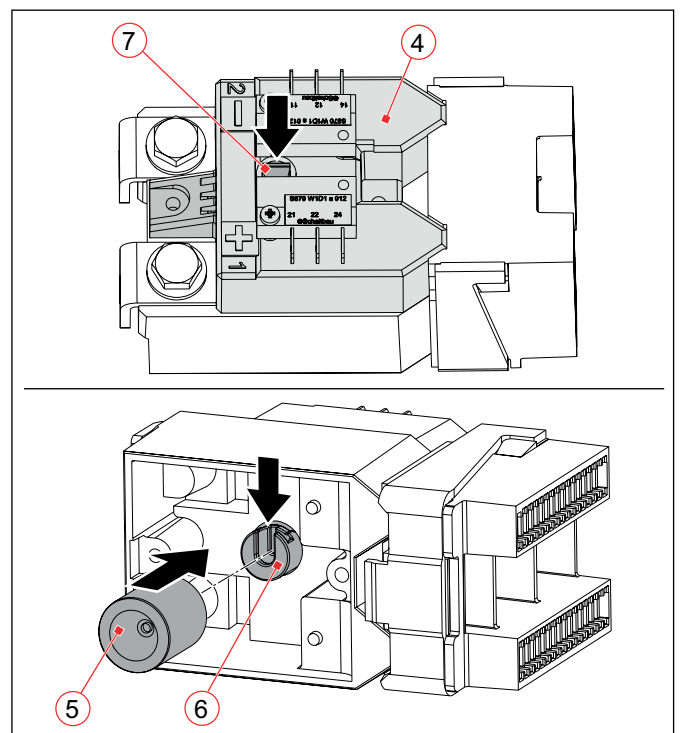

Fig. 62: C195 A/, C195 B/: Assembling the armature (the figure shows C195 A/, the procedure is identical for C195 B/)

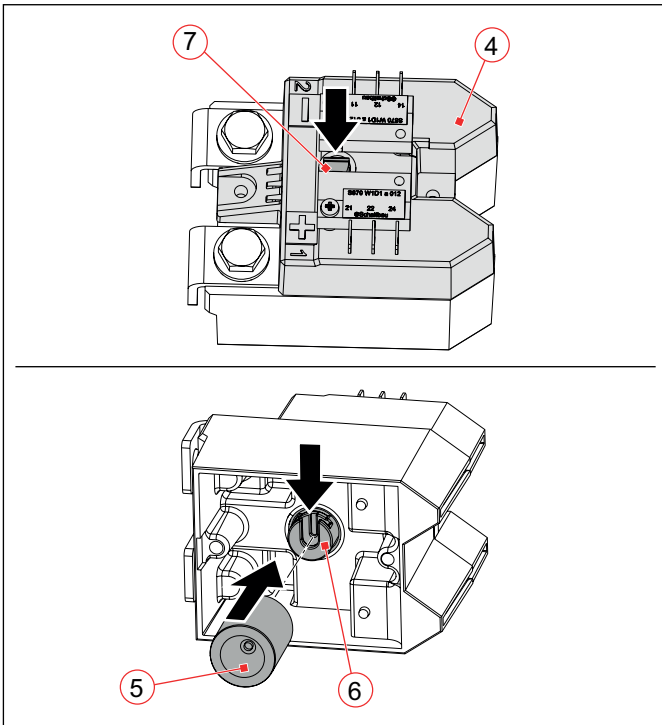

Fig. 63: C195 S/, C195 T/: Assembling the armature
(the figure shows C195 S/, the procedure is identical for C195 T/)

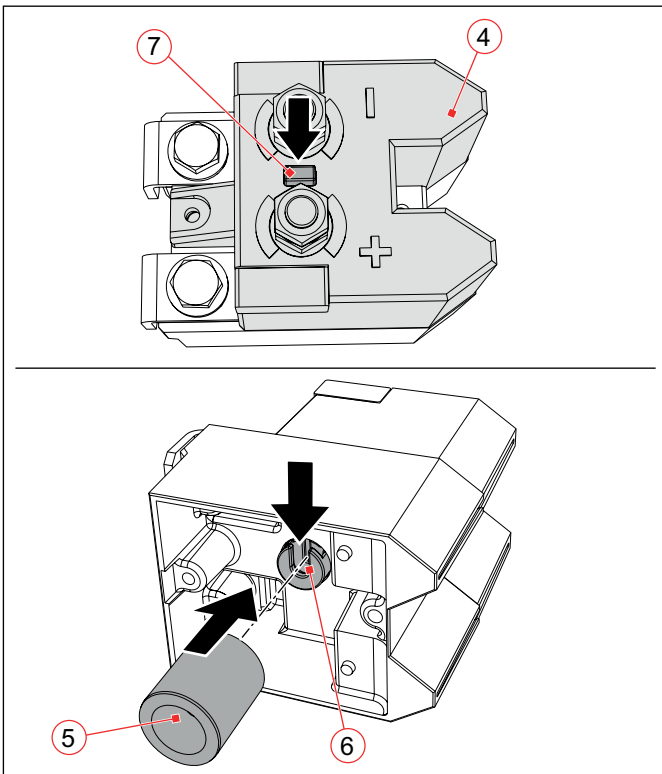



Fig. 64: C195 W/: Assembling the armature

8.4.5 Removing/attaching the cover – type C195 A/, B/, S/, T/, W/

Tools required

- Set of Torx bits or Torx screwdriver set
- Continuity tester
- Torque spanner

	<p>⚠ DANGER</p>
<p>Before beginning any work on the contactors, make sure that</p> <ul style="list-style-type: none"> ▶ there is no voltage present, ▶ all safety regulations are fully observed. ▶ Be sure to observe section "8.1 Safety" on page 32. 	

Removing the cover – type C195 A/, B/, S/, T/, W/

- ▶ Remove all connecting cables or busbars from the main contacts, auxiliary switches and coil connections, see section "7.2 Electrical connection" on page 21.
- ▶ Unscrew the 2 screws (1) on the cover (4) of the contactor.
- ▶ Remove the cover (4) upwards from the contact unit (2).

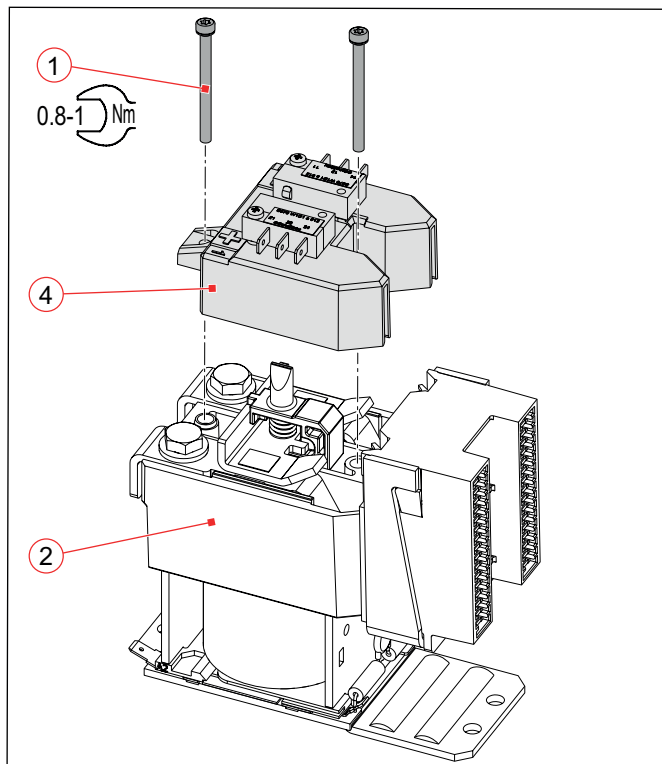

Fig. 65: C195 A/, C195 B/: Removing/attaching the cover (the figure shows C195 A/, the procedure is identical for C195 B/)

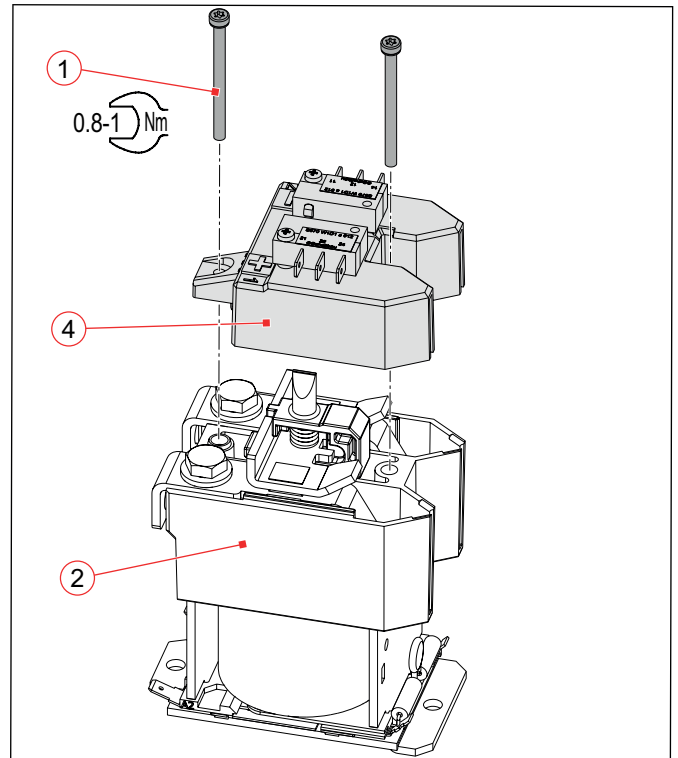

Fig. 66: C195 S/, C195 T/: Removing/attaching the cover (the figure shows C195 S/, the procedure is identical for C195 T/)

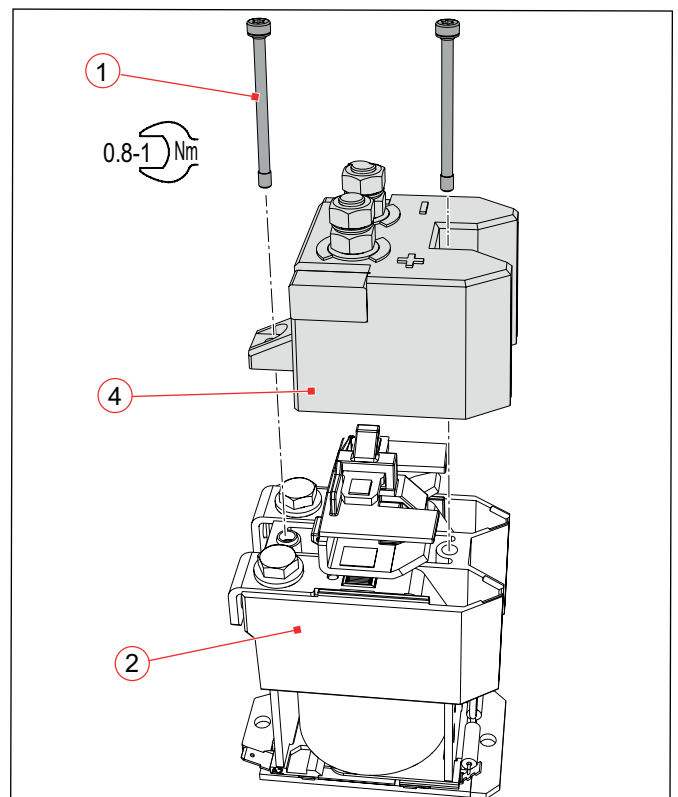

Fig. 67: C195 W/: Removing/attaching the cover

Attaching the cover – type C195 A/, B/, S/, T/, W/

- ▶ Place the cover (4) on the contact unit (2).
 - Make sure that the contact bridge does not twist.
- ▶ Screw in the 2 screws (1) on the cover (4) of the contactor and tighten them with a torque of 0.8-1 Nm.
- ▶ Reconnect all connecting cables or busbars (main contacts, auxiliary switches and coil connections), see **"7.2 Electrical connection"** on page 21.
- ▶ Finally, subject the contactor to a complete check as described in section **"7.4 Checks"** on page 31.

8.4.6 Disassembling/assembling the magnetic drive – type C195 A/, B/, S/, T/, W/

Tools required

- Set of Torx bits or Torx screwdriver set
- Continuity tester
- Torque spanner

	⚠ DANGER
	<p>Before beginning any work on the contactors, make sure that</p> <ul style="list-style-type: none"> ▶ there is no voltage present, ▶ all safety regulations are fully observed. ▶ Be sure to observe section "8.1 Safety" on page 32.

Disassembling the magnetic drive – type C195 A/, B/, S/, T/, W/

- ▶ Remove all connecting cables or busbars from the main contacts, auxiliary switches and coil connections, see section **"7.2 Electrical connection"** on page 21.

ATTENTION
<p>Incorrect installation of the contact unit due to two possible installation positions leads to malfunctions and destruction of the contactor.</p> <ul style="list-style-type: none"> ▶ Before disassembling, note the orientation of the contact unit in relation to the base plate.

- ▶ Unscrew the 2 screws (1) on the cover (4) of the contactor.

- ▶ Carefully lift the contact unit (2) off the magnetic drive (3).
 - Make sure that the cover (4) does not lift off the housing of the contact unit (2).

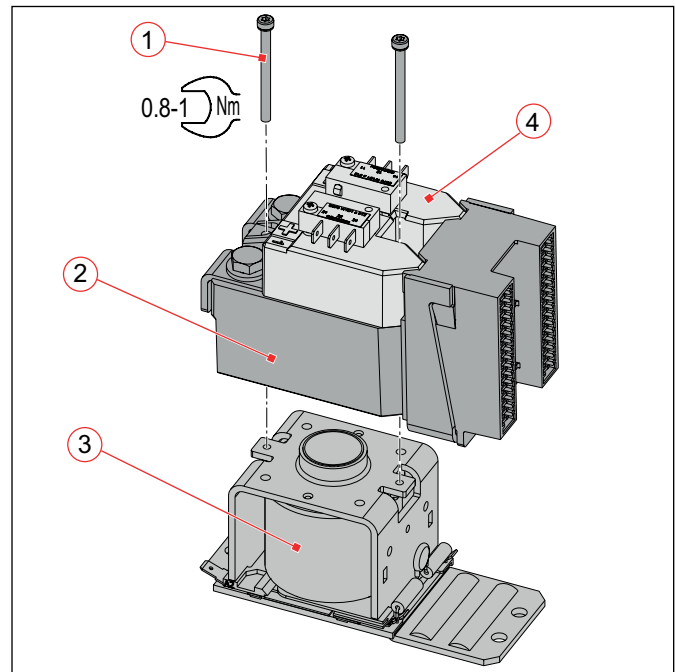

Fig. 68: C195 A/, C195 B/: Disassembling/assembling the magnetic drive (the figure shows C195 A/, the procedure is identical for C195 B/)

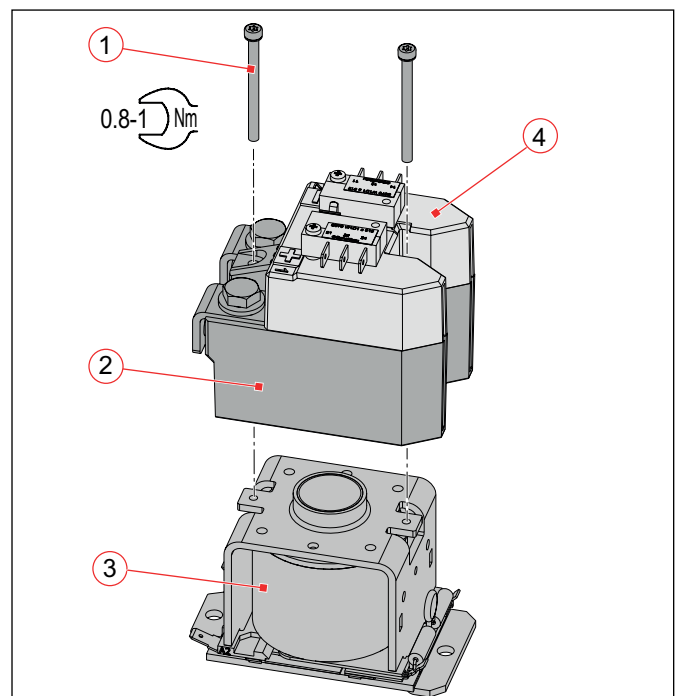

Fig. 69: C195 S/, C195 T/: Disassembling/assembling the magnetic drive (the figure shows C195 S/, the procedure is identical for C195 T/)

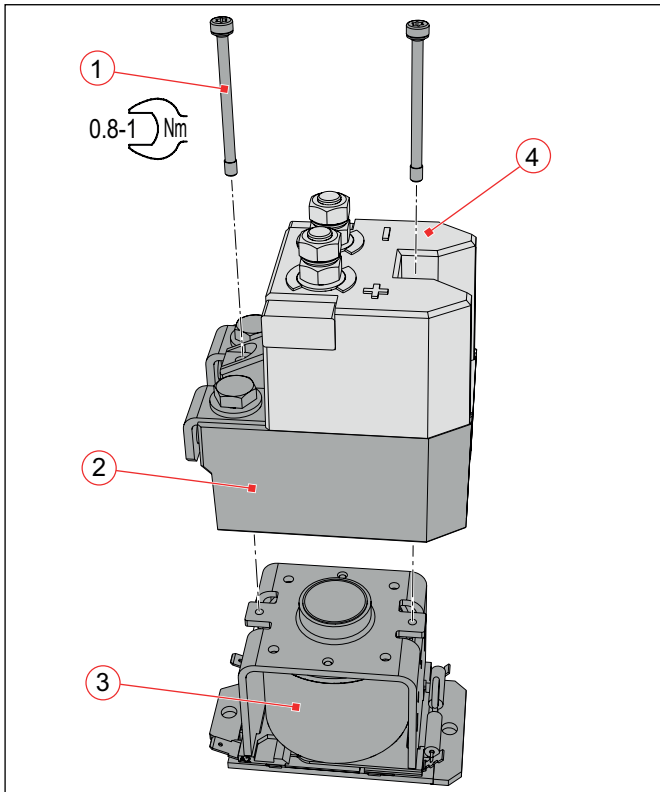

Fig. 70: C195 W/: Disassembling/assembling the magnetic drive

Assembling the magnetic drive – type C195 A/, B/, S/, T/, W/

ATTENTION

Incorrect installation of the contact unit due to two possible installation positions leads to malfunctions and destruction of the contactor.

- ▶ Before installing the contact unit on the magnetic drive, observe the previously noted correct orientation in relation to the base plate.
- ▶ Carefully place the contact unit (2) on the magnetic drive (3).
 - Make sure that the cover (4) does not lift off the housing of the contact unit (2).

When using a new magnetic drive, new screws (1) with coating for screw securing are included in the scope of delivery. Only use the new screws supplied.

ATTENTION

When reassembling the old magnetic drive with the old screws, the operator himself must ensure that the old screws are professionally cleaned and secured.

- ▶ Screw the contact unit (2) onto the magnetic drive (3) using the two screws (1) and tighten it with a torque of 0,8-1 Nm.
- ▶ Reconnect all connecting cables or busbars (main contacts, auxiliary switches and coil connections), see "7.2 Electrical connection" on page 21.
- ▶ Finally, subject the contactor to a complete check as described in section "7.4 Checks" on page 31.

8.4.7 Disassembling/assembling the arcing chamber – type C195 A/ and C195 B/

Tools required

- Set of Torx bits or Torx screwdriver set
- Continuity tester
- Torque spanner

	<p>⚠ DANGER</p>
	<p>Before beginning any work on the contactors, make sure that</p> <ul style="list-style-type: none"> ▶ there is no voltage present, ▶ all safety regulations are fully observed. ▶ Be sure to observe section "8.1 Safety" on page 32.

Disassembling the arcing chamber – type C195 A/ und C195 B/

- ▶ Remove all connecting cables or busbars from the main contacts, auxiliary switches and coil connections, see section **"7.2 Electrical connection"** on page 21.
- ▶ Remove the cover from the contact unit (2), see section **"Removing the cover – type C195 A/, B/, S/, T/, W/"** on page 53.
- ▶ Hold the lower part of the contact unit (2) and pull out the arcing chamber (12) upwards.

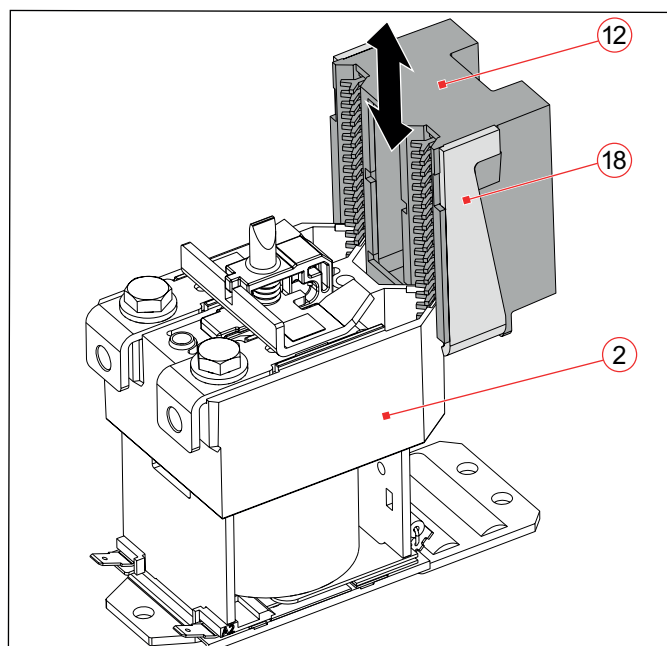

Fig. 71: C195 A/, C195 B/: Disassembling/assembling the arcing chamber (the figure shows C195 A/, the procedure is identical for C195 B/)

Assembling the arcing chamber – type C195 A/ und C195 B/

ATTENTION

Incorrect installation of the arcing chamber due to two possible installation positions can cause malfunctions and destruction of the contactor.

- ▶ Before installing the arcing chamber, make sure that the open end of the U-shaped metal bracket (18) points upwards, see **Fig. 71**.

- ▶ Push the new arcing chamber (12) into the contact unit (2) as far as it will go.
- ▶ Place the cover on the contact unit (2), see section **"Attaching the cover – type C195 A/, B/, S/, T/, W/"** on page 54 .
- ▶ Tighten the contact unit including cover to a torque of 0.8-1 Nm.
- ▶ Reconnect all connecting cables or busbars (main contacts, auxiliary switches and coil connections), see **"7.2 Electrical connection"** on page 21.
- ▶ Finally, subject the contactor to a complete check as described in section **"7.4 Checks"** on page 31.

8.4.8 Replacing the auxiliary switches – type C195 A/, B/, S/, T/

Under normal working condition (there have been no short circuits in the control circuit) the life time of the auxiliary switches exceeds those of the contactor. However, in the event of a short circuit in the control circuit, it is possible that the auxiliary switches may be damaged and need to be replaced.

Spare parts required

- Auxiliary switch assembly (2 auxiliary switches with self-tapping screws),
- or 1 auxiliary switch with self-tapping screws for latching versions, see chapter “9. Spare parts”.

Procedure

- ▶ For the procedure for replacing the auxiliary switches, see section “8.4.2 Disassembling/Assembling the auxiliary switches – type C195 A/, B/, S/, T/” on page 46.
- ▶ Finally, subject the contactor to a complete check as described in section “7.4 Checks” on page 31.

8.4.9 Replacing the complete contact unit – type C195 A/, B/, S/, T/, W/

Spare parts required

Contact unit complete
 (Housing with contact bridge unit, main contacts, cover and – if applicable for the respective type – arcing chamber complete as well as blowing unit with permanent magnets), see chapter “9. Spare parts”.

Procedure

- ▶ For the procedure for replacing the contact unit, see section “8.4.3 Disassembling/assembling the contact unit – type C195 A/, B/, S/, T/, W/” on page 49.
- ▶ Finally, subject the contactor to a complete check as described in section “7.4 Checks” on page 31.

8.4.10 Replacing the armature – type C195 A/, B/, S/, T/, W/

Spare parts required

Armature according to the type of contactor. See chapter “9. Spare parts”.

Procedure

- ▶ For the procedure for replacing the armature see section “8.4.4 Disassembling/assembling the armature – type C195 A/, B/, S/, T/, W/” on page 51.
- ▶ Finally, subject the contactor to a complete check as described in section “7.4 Checks” on page 31.

8.4.11 Replacing the magnetic drive – type C195 A/, B/, S/, T/, W/

Spare parts required

Magnetic drive with preset coil voltage depending on the type of contactor. See chapter “9. Spare parts”.

Procedure

- ▶ For the procedure for replacing the magnetic drive see section “8.4.6 Disassembling/assembling the magnetic drive – type C195 A/, B/, S/, T/, W/” on page 54.
- ▶ Finally, subject the contactor to a complete check as described in section “7.4 Checks” on page 31.

8.4.12 Replacing the arcing chambers – type C195 A/and C195 B/

Spare parts required

Arcing chambers complete (arcing chambers with arcing plates), see chapter “9. Spare parts”

Procedure

- ▶ For the procedure for replacing the arcing chambers see section “8.4.7 Disassembling/assembling the arcing chamber – type C195 A/and C195 B/” on page 56.
- ▶ Finally, subject the contactor to a complete check as described in section “7.4 Checks” on page 31.

9. Spare parts



Important!

Depending on the type of contactor, there are different versions of spare parts to be used.

When ordering spare parts, always specify the precise type and article number of the contactor. You can find this data on the rating plate.

Designation	Components	C195 series, type							
		X/	A/	A/ ...BD	B/	S/	S/ ...BD	T/	W/
Auxiliary switch group	Snap-action switches (2 pieces) with self-tapping screws	x	x	---	x	x	---	x	---
Auxiliary switch	Snap-action switch (1 piece) with self-tapping screws	---	---	x	---	---	x	---	---
Contact unit complete	Contact unit complete (housing with contact bridge unit, main contacts, cover and – if applicable for the respective type – arcing chambers complete as well as blowing unit with permanent magnets)	x	x	x	x	x	x	x	x
Magnetic drive	Base plate, coil unit with yoke	x	x	x	x	x	x	x	x
Arcing chamber complete	Arcing chamber with arcing plates	x	x	x	x	---	---	---	---
Armature	Magnetic armature	x	x	x	x	x	x	x	x

10. Technical data

Technical data and information on the material properties for the contactors of the C195 series are given in our *B195 catalogue*.

Schaltbau products are subject to continual improvement. Therefore, the product information in catalogues, data sheets, etc. may change at any time. Therefore, only the latest version of a catalogue is valid at any time – downloads available under:

<https://www.schaltbau.com/en/media-library/>

11. Disposal

This product is designed for exclusive professional use by commercial companies. The owner is responsible for ensuring an environmentally sound disposal of this product at the end of its working life.

This product or parts of it may not be disposed of with other household waste.

To prevent possible harm to the environment or human health from uncontrolled waste disposal, please separate this product or parts of it from other types of wastes and recycle it responsibly to promote the sustainable reuse of material resources.

Please observe all local regulations and recommendations for the disposal, recycling or environmentally friendly processing of the parts and materials that have been used or replaced during installation, operation, and maintenance tasks.

At the end of the product's useful life ensure environmentally sound disposal of the product according to the legal regulations and requirements for electrical and electronic waste equipment in your country.

Schaltbau GmbH

For detailed information on our products and services visit our website – or give us a call!

Schaltbau GmbH
Hollerithstrasse 5
81829 Munich
Germany



Phone +49 89 9 30 05-0
Fax +49 89 9 30 05-350
Internet www.schaltbau.com
e-Mail contact@schaltbau.de

with compliments:



The production facilities of Schaltbau GmbH have been IRIS certified since 2008.



Certified to DIN EN ISO 14001 since 2002. For the most recent certificate visit our website.



Certified to DIN EN ISO 9001 since 1994. For the most recent certificate visit our website.

Electrical Components and Systems for Railway Engineering and Industrial Applications

Connectors

- Connectors manufactured to industry standards
- Connectors to suit the special requirements of communications engineering (MIL connectors)
- Charging connectors for battery-powered machines and systems
- Connectors for railway engineering, including UIC connectors
- Special connectors to suit customer requirements

Snap-action switches

- Snap-action switches with positive opening operation
- Snap-action switches with self-cleaning contacts
- Enabling switches
- Special switches to suit customer requirements

Contactors

- Single and multi-pole DC contactors
- High-voltage AC/DC contactors
- Contactors for battery powered vehicles and power supplies
- Contactors for railway applications
- Terminal bolts and fuse holders
- DC emergency disconnect switches
- Special contactors to suit customer requirements

Electrics for rolling stock

- Equipment for driver's cab
- Equipment for passenger use
- High-voltage switchgear
- High-voltage heaters
- High-voltage roof equipment
- Equipment for electric brakes
- Design and engineering of train electrics to customer requirements