

PRODUCT INFORMATION

C130/180, C130/250

Combination contactors for battery voltages



Schaltbau's competitively-priced all-in-one device is a combination of line contactor, main fuse and manual cut-off switch in which additional devices as well as an optional horn can be integrated. Typical applications are battery powered warehouse machines, such as fork lift and reach trucks as well as walk-behind trucks and stackers.

Features:

- Compact design
- Emergency stop switch with rugged snap mechanism
- Battery contactor with main fuse
- Magnetic blowout
- Double-break contacts, cadmium-free
- Optional horn and fuse

Standard:

- EN 1175

Dimension diagram

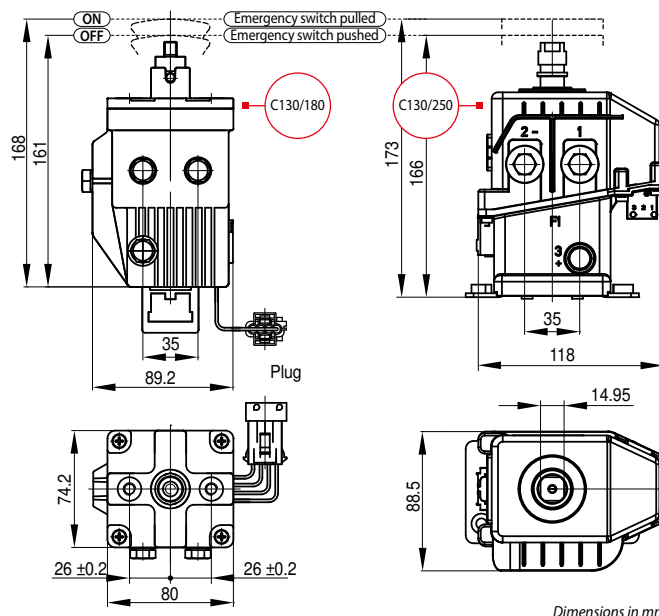

Specifications

Series	C130/180	C130/250
Kind of voltage	DC	
Main contact, # of, configuration	1x SPST-NO	
Nominal voltage U_n	24 V	80 V
Rated insulation voltage U_i	150 V	
Rated impulse withstand voltage U_{imp}	2.5 kV	
Pollution degree Overvoltage category	PD3 OV3	
Conventional thermal current I_{th}	180 A / 140 A**	250 A / 120 A**
Aux. contact, # of, configuration	1x SPDT	2x SPDT
Coil voltage U_s	24 / 48 V	
Mechanical endurance	> 3 million cycles	

* Others on request ** with fuse