

1

Connectors

LV500 series

High Power Connectors
for faster charging
of industrial trucks

Catalogue A86.en

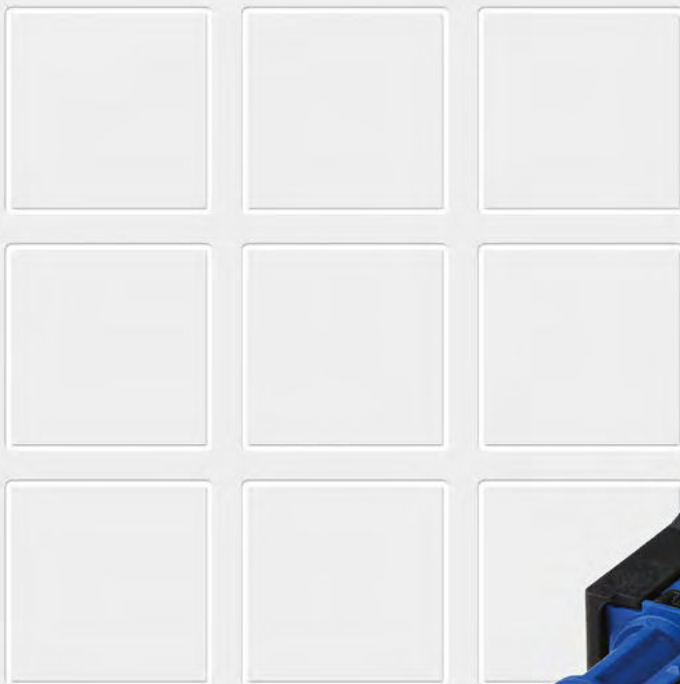

more information here:
schaltbau-gmbh.com

LV500 More Power for Faster Charging

Schaltbau LV500 series charging connectors assure safe operation and high reliability in the long term.

Delivering maximum performance and working in harsh environmental conditions requires reliable, durable and safe products. It is exactly these requirements that are met by the new Schaltbau charging connector. The

low-maintenance and high-performance connector fulfils the expectations of the contemporary user: Modern fast chargers recharge vehicle batteries in short time or traditionally over night.

Features

Series LV500

- **Higher current-carrying capacity**

The LV500 charging connectors comply with UL 1977 for a higher current-carrying capacity of 500 A.

- **High-quality, screw-machine power contacts**

Due to an improved design, the contacts feature a higher current-carrying capacity, minimum contact heating and a continuous low contact resistance. With constant contact force over its working life, the connector is less susceptible to wear and tear while mating and unmating.

- **Modular design**

Standardized individual components can be used across the entire connector series. They allow for a customized and cost-effective realisation of your applications, and avoid unnecessary stocking of items.

- **Integrated lock function**

The mated shells of the LV Series connectors provide positive locking resistance to shock, vibration and other decoupling forces that may occur under normal conditions of use.

- **High resistance to acids and extremes of temperature**

The material used for the connector shells including strain relief is highly resistant to sulphuric acid of high concentration.

The proven housing material makes for the connector's ruggedness and suitability for use with temperatures ranging from -30° C to +130° C.

- **Auxiliary contacts, air tube adapter / additional pilot contact adapter**

Auxiliary contacts: Can be used for the function of the battery management system, which constantly monitor the condition of the battery, thereby guaranteeing maximum battery life.

Schaltbau LV500 series charging connectors can be equipped with an additional air tube or pilot contact adapter.

Do you need these options? For more information see on page 5 or in our catalogue A841:

➔ ["Multifunctional adapters for LV160 and LV320 series"](#)

Air tube adapter: For use with batteries with electrolyte circulation system or

Pilot contact adapter: To be fitted with 2 optional pilot contacts which provide a data link between the battery management system and the charger.

UL approval

Series LV500

UL approval (Underwriters Laboratories):

The LV500 series is UL1977 certified for electrical products.

Specifications

Series LV500

Example: **LV500-0-S10/AWG4/0-0-2-L0-H3**

Series	LV500	Rated operating current 500 A
Keying plug	0	---
Contacts, wire gauge	S10/AWG4/0	Socket AWG4/0
	P10/AWG4/0	Pin AWG4/0
Pilot contacts	0	---
	2	2 pilot contacts *1
Aux. contacts	0	---
	2	2 aux. contacts
Air tube adapter	L0	---
	L1	With *1
Handle	H0	---
	H1/S	Black, screw on
	H3	Black, snap on

**Note:**

Presented in this catalogue are only stock items which can be supplied in short delivery time. For some variants minimum quantities apply. Please do not hesitate to ask for the conditions.

Special Variants:

If you need a special variant, please do not hesitate to contact us. Maybe the type of charging connector you are looking for is among our many special designs. If not, we can also supply customized designs. In this case, however, minimum ordering quantities apply.

Assembled connectors

Series LV500

Do you need assembled connectors? If so, do not hesitate to contact us! We supply receptacles and plugs complete with pre-assembled cables of different lengths and wire gauges and with a variety of cable terminal ends for the battery to suit your requirements. Schaltbau guarantees a constant high quality of the pre-assembled connector.

Wire gauges / cables / terminal ends:

- AWG 4/0 / Fa. Cable USA Inc. #SRK 734X01C6 / Battery terminal conductor with cable lug

Wire connection:

- Main contacts: w/ crimping
- Pilot/aux. contacts: crimping

Marking of cables:

- Red shrink tube ⊕ - terminal
- Blue shrink tube ⊖ - terminal
- Product named on rubber jacket of cable

Strain relief:

- All cables are secured against stress and strain by the strain relief clamp being an integral component of the connector shell.

Air tube adapter:

- For air tube with inside diameter Ø 6 mm, wall thickness 1.5 mm, Shore 73

Quality assurance:

- DIN EN ISO 9001:2008
- DIN EN ISO 14001:2015

Series	LV500	
Rated operating current *1	UL 1977	
Main contacts	UL / CSA	500 A / 300 A
Pilot/aux contacts	UL / CSA	20 A / 1 A
Rated voltage	UL, CSA	150 V
Main contacts		
Number of		2
Contact diameter		10 mm
Wire gauge		4/0 AWG *2
Pilot contacts		
Number of		2
Contact diameter		4 mm
Wire gauge		2,5 mm ²
Aux. contacts		
Number of		2
Contact diameter		4 mm
Wire gauge		2,5 mm ²
Air tube adapter		
Adapter for air tube size		6 mm
Crimped connection		
Main contacts		w/ crimping *3
Pilot contacts		crimping
Ingress protection rating (IP code)		IP23 *4
Temperature range		-30 °C ... +130 °C *5,6
Mating cycles		5,000
Shells		
PBT GF30 (PBB and PBDE free)		•
Integrated lock function		•
Strain relief		•
Flammability rating		UL 94-V0
Handle styles		
Snap-on		•
Screw-on		•
Handle colour		
Black		•
Approvals	UL 1977	 File No. E242089

*1 Schaltbau LV500 series charging connectors can be equipped with an additional air tube or pilot contact adapter. Do you need these options? For more information see on page 5 or in our catalogue A841: ["Multifunctional adapters for LV160 and LV320 Series"](#)

*2 Drop height of 1 m max.

*3 Assembly and crimping instructions, see manual [A84-M.de](#)

*4 IPx3 when mounted horizontally

*5 For cable of the company Cable USA Inc. #SRK 734X01C6, specified up to 200° C. Attention! High temperatures, please take suitable protective measures, e.g. wear suitable protective gloves

*6 Current-carrying capacity curves on page 4

Charging plug/vehicle plug

Series LV500

• Dimension diagrams

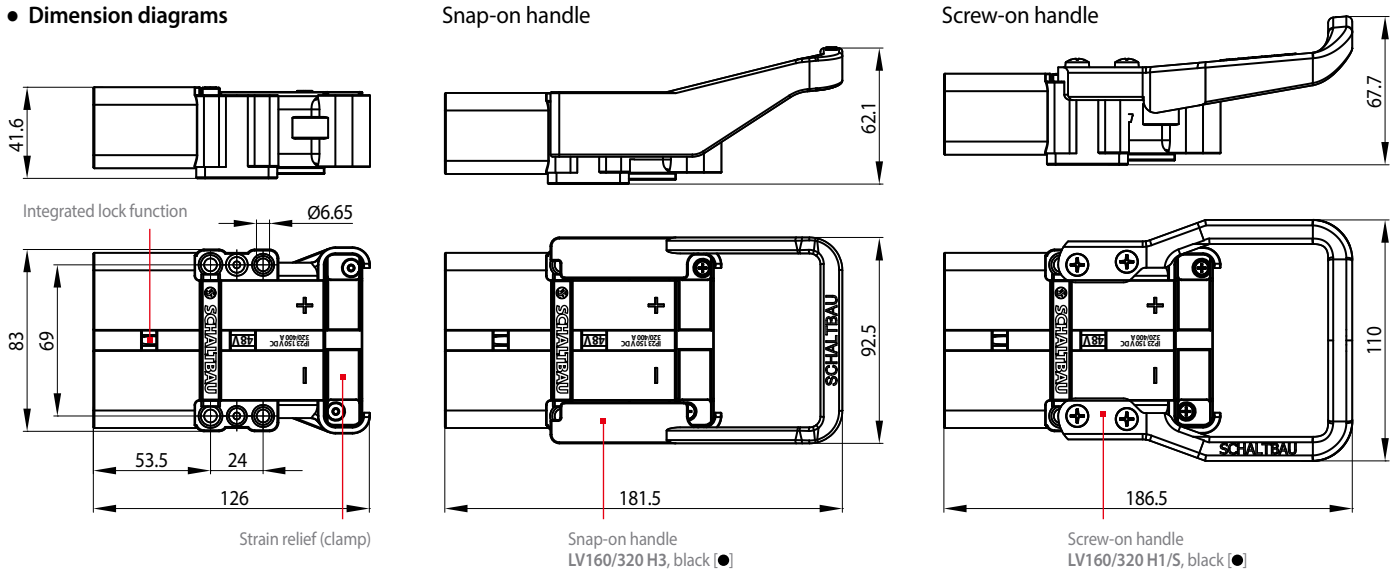

Main contacts, aux. contacts

Series LV500

• Main contacts

Ordering code	Type	Wire gauge	Rated current
LV500 S10/AWG4/0	Socket	AWG4/0	500 A
LV500 P10/AWG4/0	Pin	AWG4/0	500 A

• Auxiliary contacts

Ordering code	Type	Wire gauge	Rated current
LV320 BCC-2.5-Ag	Socket	2.5 mm ²	5 A
LV320 SCC-2.5-Ag	Pin	2.5 mm ²	5 A

• Current-carrying capacity curves of main contacts with cable AWG4/0

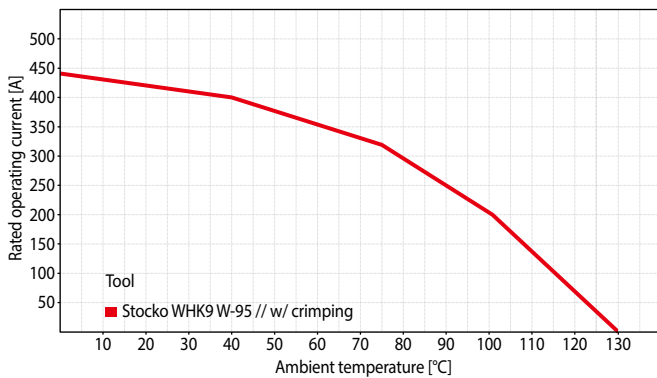

• Derating curves of main contacts with cable AWG4/0

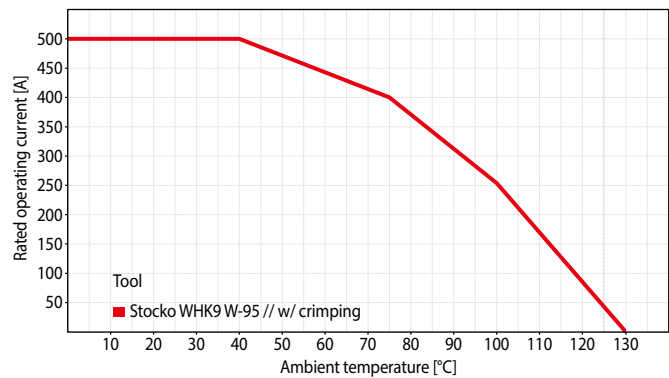

Note:

- **Wire gauge:** Reducers also reduce the current rating.
- **High Power Connectors:** Connectors with high current-carrying capacity require a wire gauge of AWG 4/0 (95 mm²). The use of reducers is not allowed.
- **Maximum current-carrying capacity curves:** Determined solely by the wire gauge – the use of reducers has no bearing on the maximum current-carrying capacity curve. The values are only valid for the main contacts with w/ crimping.

Reduced scale diagrams / dimensions in mm

Battery receptacle

Series LV500

• **Dimension diagrams**

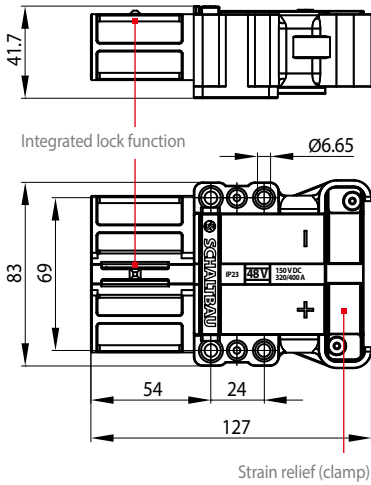

Snap-on handle

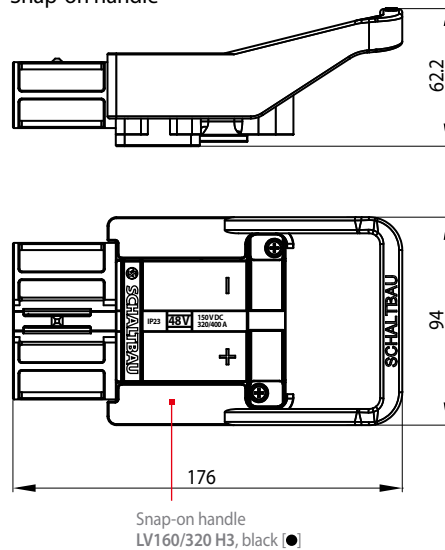

Screw-on handle

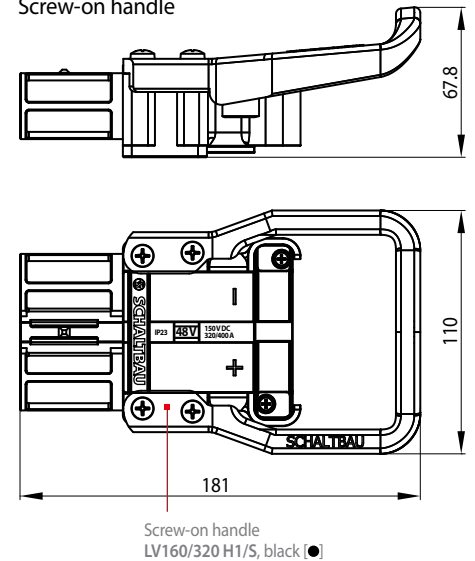

Adapters Pilot contact adapter, air tube adapter, multifunctional adapter

Series LV500

Adapter options for customizing your LV Series charging connector:

• **Pilot contact adapter**

Adapter to be fitted with 2 additional pilot contacts for monitoring the battery state and other control functions.

Pilot contact adapter	Ordering code for LV500 series
Set*: 1x adapter + 2x socket contacts	LV160/320 P-S/S
Set*: 1x adapter + 2x pin contacts	LV160/320 P-P/S

* See also table on page 4, wire gauge AWG 13 (2.5 mm²)

• **Air tube adapter**

Air supply for batteries with electrolyte circulation system. Electrolyte circulation ensures that the electrolyte is gently mixed by an airstream while the battery is being recharged and prevents the battery acid from becoming layered in the individual cells. This results in a shorter charging time and in reduced energy and water consumption.

Air tube adapter	Ordering code for LV500 series
1x adapter for receptacle shell* + 1x spacer*	LV160/320 LV-S LV160/320 DS-LS
1x adapter for plug shell* + 1x spacer*	LV160/320 LV-P LV160/320 DS-LP

* See also table on page 4, connection for air tubes with inside diameter Ø 6 mm

• **Multifunctional adapter**

Multipurpose adapter for water top up and electrolyte circulation systems. The new feature that the flow of air and/or water is shut off when the connector is unmated. For more information, especially on the multifunctional adapter:

- www.schaltbau-gmbh.com ➔ schaltbau.info/lv-adapter-en
- Catalogue A841: ➔ schaltbau.info/download1en

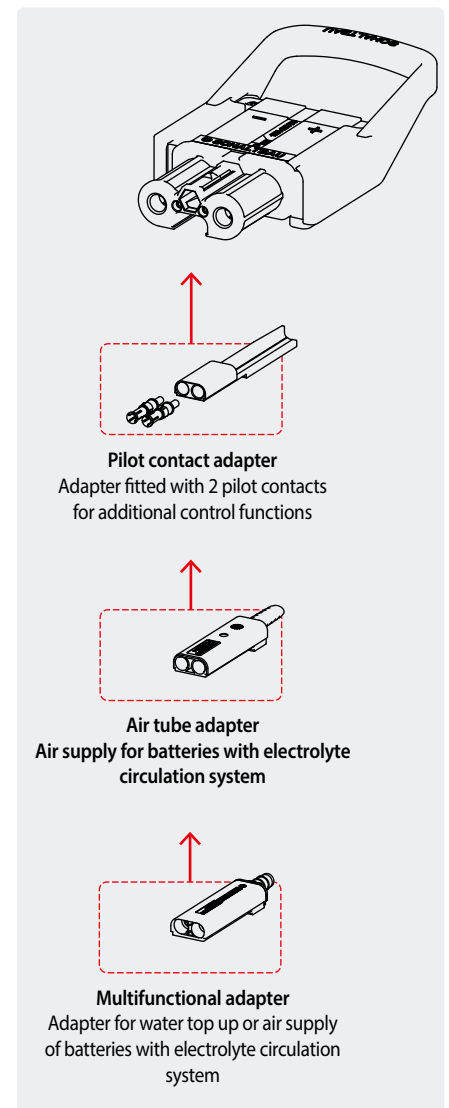



Hydraulic crimping tool Stocko WHPH 10
for the main contacts AWG4/0

• **w/ crimping of main contacts**

The applicable standard for crimping the main contacts is IEC 60352-2 – Solderless crimped connections. Schaltbau requires w/ crimping of main contacts. For that purpose Schaltbau recommends the use of the hand tool WHPH 10 and for major quantities the hydraulic crimping heads WHK 8S, WHK 8 and WHK 9 respectively of the company Stocko.

Order from: Stocko (www.stocko.de) or retailer

Ordering code: Stocko WHPH 10 or comparable tool of other manufacturers



Crimp tool CWZ-600-1
for both pilot and auxiliary contacts

• **Crimping of pilot and auxiliary contacts**

The applicable standard for crimping of pilot and auxiliary contacts is IEC 60352-2 – Solderless crimped connections. Schaltbau recommends the use of crimp tool CWZ-600-1 for wire sizes AWG 25 ... 9 (0.14 ... 6.00 mm²).

Order from: Schaltbau GmbH

Ordering code: Crimp tool CWZ-600-1



Extraction tool AWZ-C/H
for pilot contacts of the
LV500 series

• **AWZ-C/H Extraction tool for pilot and aux. contacts**

The tools are designed for the removal of pilot and auxiliary contacts from the assembled connector.

Series	Type of contact	Pin	Socket	Ordering code
LV500	Pilot contact	SCC-2.5-Ag	BCC-2.5-Ag	AWZ-C/H ---*
	Aux. contact	LV320 SCC-2.5-Ag	LV320 BCC-2.5-Ag	

* Aux. contacts of the LV500 Series are secured from falling out of the shell by means of the slider.

Installation and safety instructions

Series LV

The circular industrial connectors dealt with in this catalogue are intended for use with low-voltage systems and special installations. They are designed and tested in compliance with the generally recognised state of the art. However, the improper use, operation, handling, maintenance of or tampering with electric equipment can cause serious or fatal injury to the user or others, and the appliance or other property can be damaged.



Due to our continuous improvement programme, the design of our products can be modified at any time. So some features may differ from the descriptions, specifications and drawings in the catalogue.

You can download the latest update of the catalogue at schaltbau.info/download1en. The updated catalogue renders the previous issue invalid.

Only authorized and trained personnel are allowed to plan and carry out all mechanical and electrical installations, transport, commissioning, as well as maintenance and repair work. This applies to the observation of the general installation and safety regulations for low-voltage systems as well as the proper use of tools approved for this purpose. Electric equipment requires protection from moisture and dust during installation, operation and storage.



Electrical hazards: Any exposure to the connector's live parts. Risk of electrical shock!

Observe all applicable national provisions, all safety, accident prevention and environmental regulations as well as the recognized technical rules for safe and proper working.

Installation instructions

- Work on electric equipment may only be performed by a qualified electrician or trained personnel working under the direction and supervision of a qualified electrician according to the applicable rules of electrical engineering.
- The connectors supply power and signals. They are intended for plug-in and detachable connections of components, devices and systems only.
- In order to comply with IEC 61984 make sure that always the current-carrying part of the connector – no matter whether plug or receptacle – is fitted with socket contacts.
- For optimum protection of the cable connection make sure the connector is supplied with a strain relief.
- According to IEC 60352-2 – “Solderless connections” – crimp contacts are required.
- Make sure that there is no undue strain, pressure, flexing and torsion on the cable connection.

Installation and maintenance instructions LV Series



For a detailed list of all safety, installation and maintenance instructions, download our manual [A84-M.en!](#)

Safety instructions

- Carry out regular inspections of all protection and safety devices to see if they work properly.
- According to IEC 61984 connectors used as intended must not be engaged or disengaged when live or under load.
- A connector that does not engage easily requires special attention: Check for the correct orientation or if its contacts got bent or polluted. Never use force! The connector should always engage easily.
- To prevent dust and moisture from entering, make sure that the connector, when not mated, is covered by the protective cap.
- When disengaging a connector, pull the plug and never the cable.
- Use the connector only according to its intended use. Replace or repair damaged parts exclusively with original parts. Any other use of or tampering with the connector is considered contrary to its intended use. No liability is assumed for damages and accidents caused due to non-compliance with the instructions or improper use of the connector.
- The connectors are designed for special environmental conditions as defined by “Specifications” on page 3 of this catalogue. Any use which goes beyond the limits of these specifications is not regarded as the intended use of the connector.

Visual inspections

Be sure to make visual inspections regularly. Improper handling of the connector, e.g. when hitting the floor with some impact, can result in breakage, visible cracks and deformation.



Defective and/or leaky parts must be replaced instantaneously!



Do not disconnect under load!
 According to UL specification, the disconnection of the connector under load is not permitted.

Schaltbau GmbH

For detailed information on our products and services visit our website – or give us a call!

Schaltbau GmbH
Hollerithstrasse 5
81829 Munich
Germany



Phone +49 89 9 30 05-0
Fax +49 89 9 30 05-350
Internet www.schaltbau.com
e-Mail contact@schaltbau.de

with compliments:



The production facilities of Schaltbau GmbH have been IRIS certified since 2008.



Certified to DIN EN ISO 14001 since 2002. For the most recent certificate visit our website.



Certified to DIN EN ISO 9001 since 1994. For the most recent certificate visit our website.

Electrical Components and Systems for Railway Engineering and Industrial Applications

Connectors

- Connectors manufactured to industry standards
- Connectors to suit the special requirements of communications engineering (MIL connectors)
- Charging connectors for battery-powered machines and systems
- Connectors for railway engineering, including UIC connectors
- Special connectors to suit customer requirements

Snap-action switches

- Snap-action switches with positive opening operation
- Snap-action switches with self-cleaning contacts
- Enabling switches
- Special switches to suit customer requirements

Contactors

- Single and multi-pole DC contactors
- High-voltage AC/DC contactors
- Contactors for battery powered vehicles and power supplies
- Contactors for railway applications
- Terminal bolts and fuse holders
- DC emergency disconnect switches
- Special contactors to suit customer requirements

Electrics for rolling stock

- Equipment for driver's cab
- Equipment for passenger use
- High-voltage switchgear
- High-voltage heaters
- High-voltage roof equipment
- Equipment for electric brakes
- Design and engineering of train electrics to customer requirements

Subject to change!

For updated product information visit www.schaltbau.com