

# 1

## Connectors

### LV-HPC Series

High Power Connectors  
for industrial trucks

Crimping, Installation and  
Maintenance Instructions

Manual A84-M.en



## Document Revision History

Date	Version	Reason of change	Pages
2014-06-30	01	First edition	all
2015-06-16	02	W-crimping with support New crimping pliers CWZ-600-1 Add slider LV320/400 version	15 17 19 and the following
2017-01-23	3.0	New document structure, general revision	all
2019-10-21	4.0	New designations, new contacts, general text adaptations	5, 6, 9, 11, 13, 14, 27, 29, 34

## Content

<b>1. Important basic information .....</b>	<b>4</b>
1.1 Legal indications .....	4
1.2 Conventions for this instructions .....	4
<b>2. General and safety information .....</b>	<b>4</b>
2.1 Adherence to the instructions.....	5
2.2 Liabilities of the OEM, the operating company and/or the maintenance staff.....	5
2.3 Intended use.....	5
2.4 Ambient conditions.....	6
<b>3. Residual risks and safety measures .....</b>	<b>6</b>
3.1 Electrical hazards.....	6
3.2 Mechanical hazards.....	7
3.3 Risks of fire and explosion.....	7
3.4 Measures for avoiding damages.....	7
3.5 Measures for avoiding failures.....	7
<b>4. Description.....</b>	<b>8</b>
4.1 Label .....	8
4.2 Substances which must be declared .....	8
<b>5. Crimping instructions .....</b>	<b>9</b>
5.1 Skinning.....	9
5.2 Crimping and identification .....	9
5.3 Heat-shrink tubing.....	10
5.4 Crimping quality.....	10
5.5 Crimping instructions for main contacts.....	11
5.6 Crimping instruction for pilot and auxiliary contacts.....	12
<b>6. Installation .....</b>	<b>13</b>
6.1 Installing the main contacts.....	13
6.2 Dismantling the main contacts.....	16
6.3 Installing the pilot and auxiliary contacts.....	16
6.4 Dismantling the pilot and auxiliary contacts.....	17
6.5 Installing the air tube adapter.....	18
6.6 Dismantling the pilot or air tube adapter .....	20
6.7 Installing the keying plug .....	20
6.8 Installation of handles of different models.....	21

<b>7. Maintenance</b> .....	<b>22</b>
7.1 Maintenance intervals.....	22
7.2 Daily visual and functional check by the user .....	23
7.3 Visual/functional check and maintenance by the service personnel .....	25
7.4 Plugging operation .....	26
7.5 Main contacts .....	27
7.6 Position of the main contacts and keying plugs.....	28
7.7 Pin and socket housing.....	28
7.8 Slider and lock.....	29
7.9 Heat-shrink tubings.....	30
7.10 Clamps (strain relief).....	30
7.11 Handles LV (snap-on, screwable).....	30
7.12 Pilot contact adapter and air tube adapter .....	30
7.13 Pilot and auxiliary contacts (pin, socket) .....	31
7.14 Electrolyte recirculation.....	31
7.15 Keying plugs .....	31
7.16 Cables.....	31
<b>8. Check lists</b> .....	<b>32</b>
8.1 Check list for the user of the industrial truck .....	32
8.2 Check list for the service personnel of the industrial truck.....	33
<b>9. List of spare parts</b> .....	<b>34</b>

# 1. Important basic information

## 1.1 Legal indications

Without prior written consent of Schaltbau GmbH, the crimping, installation and maintenance instructions are not allowed to be electronically or mechanically reproduced – as a whole or in parts – be distributed, changed, transmitted, translated into another language or used in any other way.

Schaltbau GmbH cannot be held liable for damage caused by not observing (or only partly observing) the crimping, installation and maintenance instructions, or from the fact that no original SCHALTBAU GmbH spare parts are used or that altered components are used.

## 1.2 Conventions for this instructions

To highlight particularly important safety instructions and other information of special importance, the following symbols are used in these instructions:

 <b>DANGER</b>
Indicates a hazardous situation with a high level of risk which, if not avoided, will result in death or serious injury.

 <b>WARNING</b>
Indicates a hazardous situation with a medium level of risk which, if not avoided, could result in death or serious injury.

 <b>CAUTION</b>
Indicates a hazardous situation with a low level of risk which, if not avoided, may result in minor or moderate injury.

<b>NOTICE</b>
Indicates a hazardous situation which, if not avoided, may result in property damage, such as service interruption or damage to equipment or other materials.

	Refers to technical features and methods aimed at facilitating work or to particularly important information.
---	---

	This symbol refers to technical features and methods that are executed correctly.
---	---

	This symbol refers to technical features and methods that are <b>not</b> executed correctly.
---	--

The figures and photos in these instructions are only for the purpose of orientation. Differences between the individual device and charging connectors, between pin and socket side as well as of the different series are not shown.

# 2. General and safety information

The device and charging connectors described here are used in industrial trucks with battery-electrical operation or similar battery-electrical applications. They are made and checked according to the approved rules of technology. Generally, electrical equipment may cause severe damages to health and material in the case of inappropriate use, incorrect operation, insufficient maintenance and impermissible interventions. Thus, the instructions for crimping, installation and maintenance of the device and charging connectors must be strictly adhered to.

If there are any ambiguities, the necessary clarification must be sought indicating the type of the device and the number of assembly. For the installation, operation and maintenance it is taken for granted that the planning and execution of the mechanical and electrical installation, the transport, the installation and the startup as well as the maintenance and repair activities

are executed by responsible experts with an adequate expert knowledge.

This is applicable to the adherence to the general safety regulations for works on high-voltage systems (e.g. DIN, VDE) as well as to the proper usage of approved tools and to the use of personal protective equipment. The device and charging connectors have to be protected from moisture, dust and acid during installation, operation or storage.

If there is any doubt, it is recommended to make use of the support of SCHALTBAU GmbH or of the manufacturers of the industrial trucks, the charging devices or the batteries for the installation, the startup and all service tasks.

	Note: The device and charging connectors may grow warm during operation.
---	--

## 2.1 Adherence to the instructions

All staff must read and understand the crimping, installation and maintenance instructions and adhere to them when working with the device.

- ▶ Always carefully observe all safety warnings!

## 2.2 Liabilities of the OEM, the operating company and/or the maintenance staff

- ▶ Observe all prevailing national regulations, all safety, accident prevention and environment protection regulations as well as the recognised technical rules for safe and proper work.
- ▶ All existing protective and safety devices have to be checked regularly for proper functioning.
- ▶ Work on electric equipment may only be performed by an expert or trained personnel working under the direction and supervision of an expert according to the applicable rules of electrical engineering.
- ▶ An expert is a person who can judge and recognise the possible dangers of the jobs commended to him based on his training, knowledge and experience and by knowledge of the appropriate regulations.
- ▶ Staff must be informed clearly about who is responsible for the maintenance of the device and charging connectors.

## 2.3 Intended use

- ▶ The device and charging connectors are exclusively destined for the use in industrial trucks with battery-electrical operation or similar battery-electrical applications.
- ▶ None of the operating conditions defined in our catalogue *A84.en* in section "*Specifications*" such as voltages, currents, ambient conditions, etc. may be changed.
- ▶ Work on the device and charging connectors must only be carried out by staff who meets the requirements set out in these crimping, installation and maintenance instructions.
- ▶ According to DIN EN IEC 61984, connectors are components which must not be plugged or disconnected under electrical voltage in the intended operation. The charging device must be switched off before the plugging and the disconnection so that no current is circulating.
- ▶ The requirements of EN 1175-1 apply to the connecting and disconnecting of the plug connections. Basically, not more than five disconnections are permissible on-load. When unplugging the device and charging connectors on-load, an electric

arc is generated. Thus, it is forbidden to disconnect on-load close to explosive substances or to ignition sources of any kind.

- ▶ After using the device and charging connectors under the conditions of an emergency cut-out, the connectors must not be used any longer and have to be disposed of.
- ▶ The device and charging connectors may generally only be operated in the completely plugged condition.
- ▶ Damaged device and charging connectors may not be operated. Especially not
  - when the keying is damaged or when the keying plug is missing,
  - when the housing is damaged,
  - when the handle is damaged or missing,
  - when the main contacts are damaged, e.g.
    - after an emergency shutdown,
    - after inappropriate plugging or unplugging on-load,
  - in the case of any residues of acid on the connectors and the cables.

Damaged device and charging connectors have to be replaced immediately.

- ▶ Stiffness of the connectors indicates a problem (e.g. dirt, damaged contacts, etc.). Plugging or unplugging with an increased effort or with force is not permissible.
- ▶ Device and charging connectors which can only be plugged with an increased effort have to be replaced.
- ▶ The device and charging connectors may only be plugged and unplugged manually. Auxiliary tools increasing the operating force, like e.g. hammer, lever and screwdriver are not permissible.
- ▶ Always use the handle/the housing for plugging and unplugging the connectors, never push or pull the cable.
- ▶ The device and charging connectors must not be poured over or contaminated with electrolyte fluids or other fluids.
- ▶ The device and charging connectors have to be kept clean. Dirt can cause the generation of leakage current, high currents and electric arcs when plugging or unplugging as well as increased plugging forces.
- ▶ Only use the device and charging connectors according to its intended use. Replace or repair damaged parts exclusively with original parts. Any other usage of or tampering with the charging connector device is considered contrary to its intended use. No liability is assumed for damages and accidents caused due to non-compliance with the instructions or improper use of the connectors.

## 2.4 Ambient conditions



### NOTICE

The device and charging connectors are constructed for specific ambient conditions.

- ▶ Only operate the device and charging connectors under the ambient conditions, like temperature ranges and IP protection classes, as defined in our catalogue *A84.en* in the section "*Specifications*".  
Download under <https://www.schaltbau.com/en/media-library/>

## 3. Residual risks and safety measures

### 3.1 Electrical hazards

	<p style="background-color: #e67e22; color: white; padding: 5px;"><b>⚠ DANGER</b></p> <p>The device and charging connectors contain energized components. There is a risk of burn, electric shock, short circuit and fire! Always observe the following safety regulations before carrying out any work on the device and charging connectors:</p> <ul style="list-style-type: none"> <li>▶ Clearly mark your work area.</li> </ul> <p>In the case of a plug connection which is connected to a charging device:</p> <ul style="list-style-type: none"> <li>▶ Switch off the charging device and make sure that it cannot be switched on again accidentally.</li> </ul> <p>In the case of a plug connection which is connected to a battery:</p> <ul style="list-style-type: none"> <li>▶ Disconnect the connecting leads from the battery.</li> </ul>
	<p style="background-color: #f1c40f; color: black; padding: 5px;"><b>⚠ WARNING</b></p> <p>The device and charging connectors are generally operated with direct-current voltage. Wear and tear and dirt on the device and charging connectors may cause the generation of leakage current, high currents and electric arcs when plugging and unplugging. Risk of electric shock!</p> <ul style="list-style-type: none"> <li>▶ Regularly check the connectors through visual checks for wear and tear and dirt as well as for residues of acid.</li> <li>▶ Immediately replace damaged parts.</li> <li>▶ Immediately remove dirt and residues of acid so that no residues remain.</li> <li>▶ Immediately replace parts with persistent dirt.</li> </ul>
	<p style="background-color: #f1c40f; color: black; padding: 5px;"><b>⚠ WARNING</b></p> <p>The plugging and unplugging of the device and charging connectors under electrical voltage generates electric arcs. Risk of electric shock!</p> <ul style="list-style-type: none"> <li>▶ Always switch off the charging device before plugging or unplugging the connectors.</li> </ul>

### 3.2 Mechanical hazards

	<b>⚠ CAUTION</b>
	<p>The device and charging connectors contain sharp-edged components. Risk of injury!</p> <ul style="list-style-type: none"> <li>▶ Use appropriate tools for installation and maintenance works on the connectors.</li> <li>▶ Wear safety gloves when handling sharp-edged components.</li> </ul>

### 3.3 Risks of fire and explosion

	<b>⚠ WARNING</b>
	<p>The plugging and unplugging of the device and charging connectors under electrical voltage generates electric arcs. Risk of fire through overheating!</p> <ul style="list-style-type: none"> <li>▶ Always switch off the charging device before plugging or unplugging the connectors.</li> </ul>

	<b>⚠ WARNING</b>
	<p>The plugging and unplugging of the device and charging connectors under electrical voltage generates electric arcs. Risk of explosion!</p> <ul style="list-style-type: none"> <li>▶ Never disconnect or plug the device and charging connectors on-load near to explosive substances or to ignitions sources of any kind.</li> <li>▶ Always switch off the charging device before plugging or unplugging the connectors.</li> </ul>

	<b>⚠ WARNING</b>
	<p>When charging batteries, hydrogen may be released. Risk of explosion!</p> <ul style="list-style-type: none"> <li>▶ Take care that there is enough air ventilation when charging batteries.</li> </ul>

### 3.4 Measures for avoiding damages

<b>NOTICE</b>
<p>Aggressive fluids may damage the device and charging connectors.</p> <ul style="list-style-type: none"> <li>▶ Make sure that the device and charging connectors do not have contact with electrolyte fluids or other fluids and that they are not contaminated by them.</li> </ul>

### 3.5 Measures for avoiding failures

<b>NOTICE</b>
<p>Inappropriate handling of the device and charging connectors, e.g. a hard hit on the ground, may cause breaks, cracks and deformations.</p> <ul style="list-style-type: none"> <li>▶ Make sure that the connectors are handled appropriately.</li> <li>▶ Do not throw the connectors to the floor.</li> <li>▶ Regularly check the connectors through visual checks for possible damages.</li> <li>▶ Immediately replace damaged connectors.</li> </ul>



## NOTICE

The plugging and unplugging of the device and charging connectors under electrical voltage generates electric arcs and causes a premature aging of the contacts and increased plugging forces. The safety of the connectors is then no longer guaranteed.

- ▶ Always switch off the charging device before plugging or unplugging the connectors.

## NOTICE

Inappropriate handling when plugging or unplugging may damage the device and charging connectors. For damaged connectors, the safety is no longer guaranteed.

- ▶ Make sure that the charging device is switched off before plugging or unplugging the connectors.
- ▶ Before plugging, make sure that the connectors are not dirty and that they are free from residues of acid. If necessary, remove any existing dirt and residues of acid.
- ▶ Take care that the connectors do not tilt and that they are plugged without force.
- ▶ Make sure that the plug connection is on principle only operated in the completely plugged condition.

## 4. Description

### 4.1 Label

The label applied to the device and charging connectors includes the following information (example):

Designation	LV series
Nominal operating current of main contacts	
Rated current I	160 A
Rated current II	250 A
Degree of protection when plugged	IP 23
Polarity	+ (PLUS), - (MINUS)
Rated voltage	150 V DC

### 4.2 Substances which must be declared

The device and charging connectors are compliant with RoHS.

Plastics contain antimony trioxide as a fire protection agent. Antimony trioxide is considered as a potentially carcinogenic substance and must therefore be declared in many cases, among others in the railway supply industry.



## 5. Crimping instructions

### 5.1 Skinning

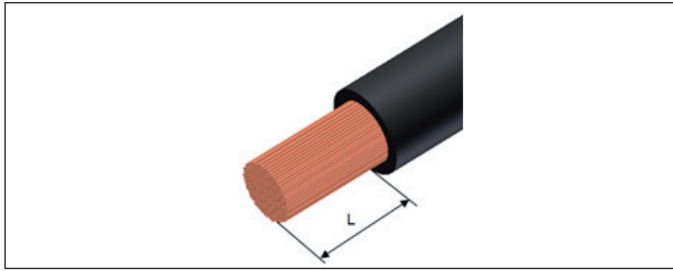

Fig. 1: Skinning length dimension L

Series	Main contacts	Cable cross section [mm <sup>2</sup> ]	Dimension L [mm] (+1)	
LV80/120	LV80 P6/25 with LV RH-25/16	16	18	
	LV80 P6/25	25		
	LV80 S6/25 with LV RH-25/16	16		
	LV80/120 S6/25	25		
LV160/250	LV160 P8.5/50 with LV RH-50/25	25	20	
	LV160 P8.5/50 with LV RH-50/35	35		
	LV160 P8.5/50	50		
	LV160 S8.5/50 with LV RH-50/25	25		
	LV160 S8.5/50 with LV RH-50/35	35		
	LV160/250 S8.5/50	50		
LV320/400	LV320 P10/50 with LV RH-50/35	35	20	
	LV320 P10/50	50		
	LV320 P10/70	70	25	
	LV320 P10/95	95		
	LV320 S10/50 with LV RH-50/35	35	20	
	LV320 S10/50	50		
	LV320 S10/70	70		
	LV320 S10/95	95		
		LV500 P10/AWG 4/0	AWG 4/0	25
		LV500 S10/AWG 4/0	AWG 4/0	

Series	Pilot and auxiliary contacts	Designation	Cable cross section [mm <sup>2</sup> ]	Dimension L [mm] (±0.5))
LV80/120	Pilot contacts	LV80 SBC-2.5-Ag pin	2.5	7.5
		LV80 BBC-2.5-Ag socket		
	Auxiliary contacts	LV80 SBC-2.5-Ag pin		
		LV80 BBC-2.5-Ag socket		
LV160/250	Pilot contacts	SCC-2.5-Ag pin	2.5	7.5
		BCC-2.5-Ag socket		
	Auxiliary contacts	LV160 SBC-2.5-Ag pin		
		LV160 BBC-2.5-Ag socket		
LV320/400	Pilot contacts	SCC-2.5-Ag pin	2.5	7.5
		BCC-2.5-Ag socket		
	Auxiliary contacts	LV320 SCC-2.5-Ag pin		
		LV320 BCC-2.5-Ag socket		

### 5.2 Crimping and identification

The indications are made for the position of the crimping using the specified pressing clamps.

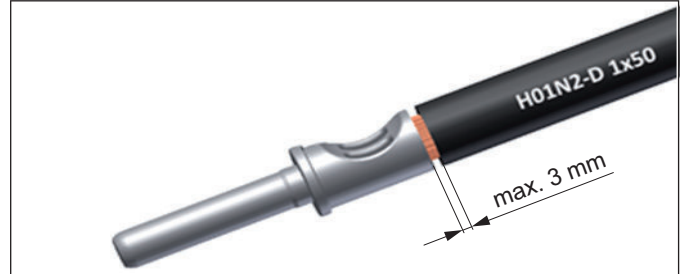

Fig. 2: Dimensions for crimping for cross sections from 16 mm<sup>2</sup> to AWG 4/0; max. 3 mm of skinning

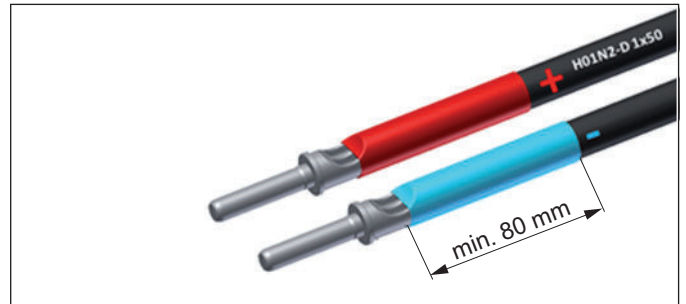

Fig. 3: Position and dimensions for the heat-shrink tubing from 16 mm<sup>2</sup> to AWG 4/0 in centre to the crimping; length of heat-shrink tubing at least 80 mm

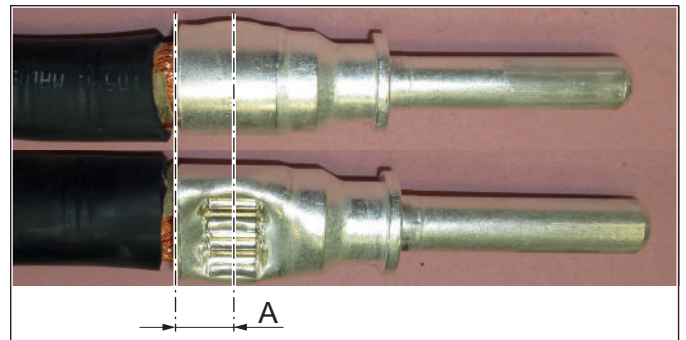

Fig. 4: Crimping position, distance A measured to the centre of the crimping

Cross sections [mm <sup>2</sup> ]	Distance A in mm measured to the centre of the crimping
50	7 ... 11
70	8 ... 11
95	9 ... 12
approx. 110; AWG 4/0	9 ... 12

## NOTICE

A distance of at least 10 mm must be kept between the heat-shrink tubing and the collar of the contact so that the slider can latch correctly.

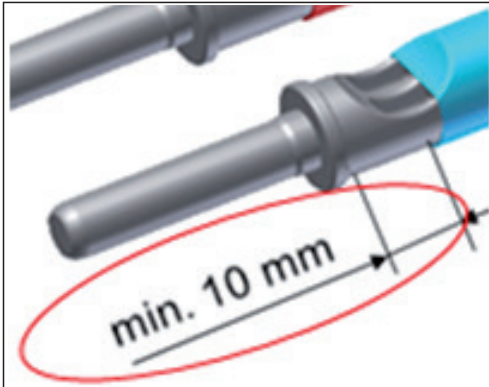

Fig. 5: Minimum distance between the heat-shrink tubing and the collar of the contact

## 5.3 Heat-shrink tubing

Schaltbau GmbH recommends the use of a flexible, flame-resistant and/or self-extinguishing heat-shrink tubing on a polyolefin basis with a good resistance against acids and alkalis.

Temperature range	-40 °C to +135 °C
Minimum shrinking temperature	+95 °C

Test	Test procedures	Requirement
Dielectric strength	IEC 243 and / or IEC 685 P2	20 MV/m
Fire protection properties		flame-resistant and/or self-extinguishing



Fig. 6: Heat-shrink tubing, shrink rate 2:1

Ø dimension of delivery minimum D [mm]	19
Ø after complete shrinking maximum d [mm]	9.5
Thickness of wall WT [mm]	0.8

## 5.4 Crimping quality

Transition resistances between crimping sleeve and cable

Cross section of cable [mm <sup>2</sup> ]	Transition resistance [µΩ] (Empirical values in the new condition)
16	50-60
25	20-40
35	10-30
50	10-20
70	up to 15
95	up to 15
~ 110; AWG 4/0	up to 15

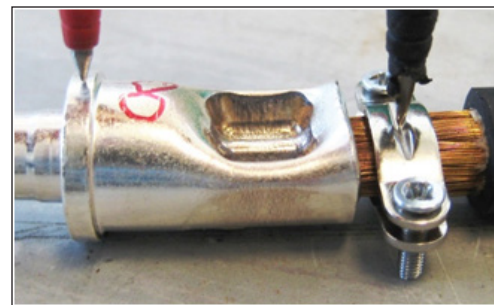

Fig. 7: Points of measurement for the transition resistance

## Compression

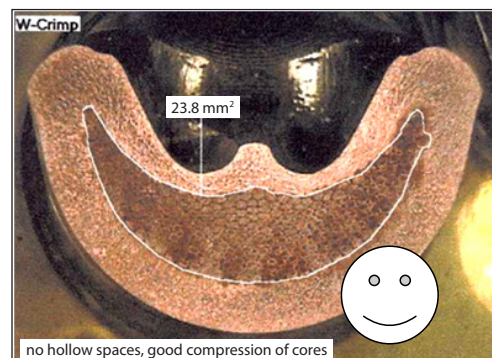

Fig. 8: Correct W crimping identified by uniformly deformed individual cores

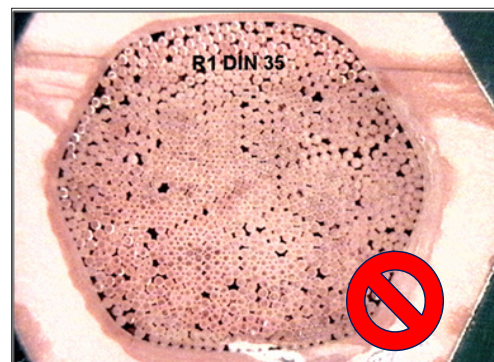

Fig. 9: Hexagon crimping with faulty compression, individual cores partially not deformed

## Extraction forces according to DIN EN 61238-1

Tensile load for cable material copper: 60 x cable cross section

Cross section of cable [mm <sup>2</sup> ]	Extraction force (N)
16	960
25	1500
35	2100
50	3000
70	4200
95	5700
~ 110; AWG 4/0	6600

## 5.5 Crimping instructions for main contacts

### General

DIN EN 61238-1 – Solderless electrical connections, crimp connections – is binding for the crimping of the main contacts.

#### NOTICE

In order to guarantee permanently working crimp connections, the following points have to be observed:

- ▶ The stranded wires must not be soldered before crimping.
- ▶ A crimped connection must **not** be soldered after crimping.

### Procedures for the crimping of main contacts

SCHALTBAU GmbH requires the W-crimping of the main contacts.

- ▶ Only W-crimping guarantees a gas-tight connection when the individual cores have been deformed properly. A structure is generated through the deformation of the crimping sleeve and the individual cores which is insulated from oxygen (cold welded) and is thus sufficiently protected from corrosion on the inside in the long term.
- ▶ W-crimping leads to an only low oxidation during operation and results in permanently low transition resistances as a basis for a low intrinsic heating of the crimping points in the case of high currents.
- ▶ When W-crimping the main contacts, take care that the contacts will not be bent.

All electrical parameters indicated by SCHALTBAU GmbH are based on measurements with contacts which have been carried out with W-crimping and the specified pressing clamps.

### Transition resistance

When the W-crimping has been carried out properly, the transition resistance of the crimping point in the new condition must be in a range of 10 ... 60  $\mu\Omega$ , depending on the cross section of the cable (refer to the table in section "5.4 Crimping quality").

### Suitable cables

Cables insulated with rubber from 16 mm<sup>2</sup> to 95 mm<sup>2</sup> (electric arc welding cables according to DIN VDE 0282-6) have to be used,

- e. g. H01N2-D
- or AWG 4/0

Cables differing from this have to be validated by the OEM/operator concerning the individual application.

### Temperature range, derating curves

The temperature range of the cables H01N2-D and AWG 4/0 lies in the range of - 30 °C ... + 90 °C taking into account the current carrying capacity curves (basis curves) and the corrected current carrying capacity curves of the permanent operation range, the derating curves (according to DIN EN 60512-5-2, Test 5b). The derating curve with the correction factor 0.8 x ln(basis curve) therefore applies to currents which may flow permanently, not intermittently, through the respective main contacts of the device and charging connectors, with a concurrent current load of 20 A max. respectively of the pilot contacts / auxiliary contacts, without the upper permissible limiting temperature of the cables of + 90° C being exceeded.

## Crimping pliers for main contacts



SCHALTBAU GmbH recommends the use of the hand crimping pliers **WHPH 10** or for larger numbers the hydraulic heads **WHK 8S**, **WHK 8** or **WHK 9** of the company Stocko or similar devices of other manufacturers. For the correct size of the pressing clamps refer to the following table.

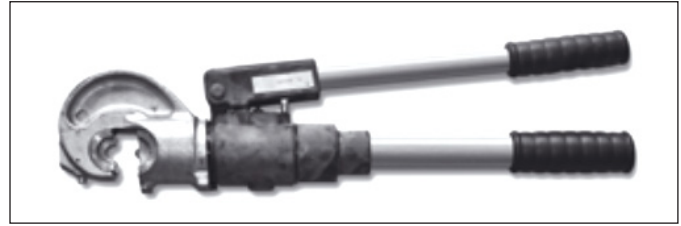

Fig. 10: Crimping pliers WHPH 10

## Determination of the pressing clamp size

Pressing clamp size (Stocko WHPH 10, WHK 6, WHK 9) for the W-crimping

Connection cross section [mm <sup>2</sup> ]	Reducing sleeve	Insert pair with control mark WHK9, STOCKO			
		Crimping anvil STOCKO-No.		Crimping stamp STOCKO-No.	
16	LV RH-25/16	25	S0.211.409	25 - 35	S0.211.502
25	---	25	S0.211.409	25 - 35	S0.211.502
	LV RH50/25	50	S0.211.423	50 - 70	S0.211.514
35	---	35	S0.211.411	25 - 35	S0.211.502
	LV RH50/35	50	S0.211.423	50 - 70	S0.211.514
50	---	50	S0.211.423	50 - 70	S0.211.514
	LV RH70/50	70	S0.211.435	50 - 70	S0.211.514
70	---	70	S0.211.435	50 - 70	S0.211.514
95	---	95	S0.211.447	95 - 150	S0.211.526
AWG 4/0	---	95	S0.211.447	95 - 150	S0.211.526

### NOTICE

At most one reducing sleeve per crimping is permissible!

## 5.6 Crimping instruction for pilot and auxiliary contacts

DIN EN 60352-2 – Solderless electrical connections, crimp connections – is binding for the crimping of the pilot contacts.



SCHALTBAU GmbH recommends the use of the crimping pliers CWZ-600-1 or similar tools of other manufacturers.



Fig. 11: Crimping pliers CWZ-600-1 for pilot und auxiliary contacts

The crimping of the pilot contacts/auxiliary contacts is made in the pressing clamp pair for a connection cross section of 2.5 mm<sup>2</sup>.

- ▶ For this purpose, insert the skinned stranded wire so far into the crimping sleeve that it becomes visible in the inspection hole.
- ▶ Insert the contact with the inserted stranded wire until the end stop into the crimping pliers.
- ▶ After that, press together the pliers beyond the latching point.



## 6. Installation

### 6.1 Installing the main contacts

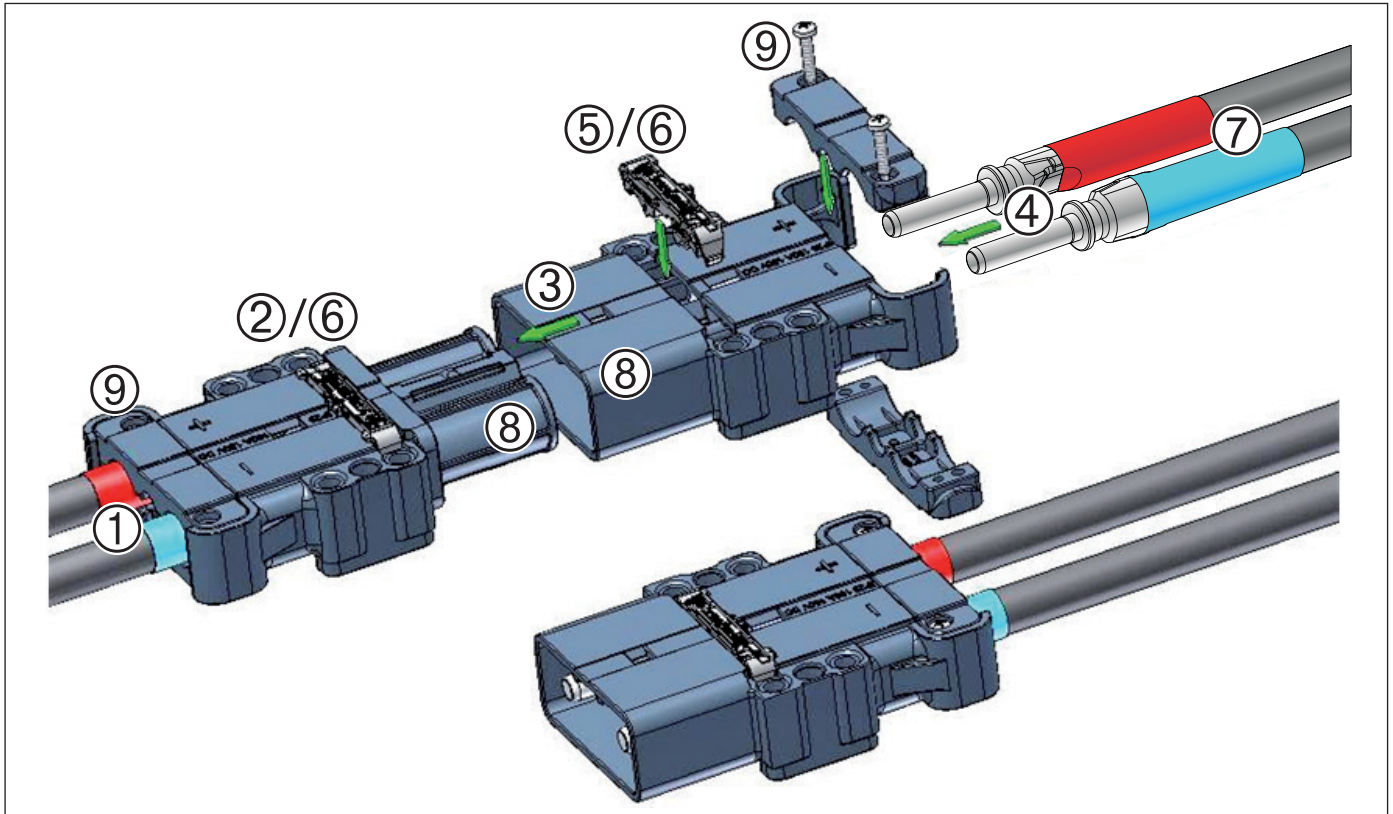



Fig. 12: Installation steps main contacts

	<p><b>⚠ WARNING</b></p>
	<p>A wrong polarity may lead to a short circuit. Risk of electric shock!</p> <p>▶ Observe the polarity identification for (+) and (-) cables on the pin or socket housings respectively.</p>

<p><b>NOTICE</b></p>	
<p>▶ For the <b>LV80/120 series</b>, first mount the <b>keying plug</b> and then the slider.</p> <p>▶ For the <b>LV320/400 series</b>, mount the <b>auxiliary contacts</b> with the main contacts as the auxiliary contacts are also interlocked with the slider.</p> <p>▶ For short main contact cables with cable lugs the overall length must be taken into account so that it does not become too short. Also pay attention to the alignment of the cable lug.</p>	

### Installing the socket and pin contacts

1. Mount the socket contacts with crimped cables into the socket housing with pre-mounted pilot contact adapter or air tube adapter including spacer.
  - Make sure that the contacts are correctly positioned in the socket housing.
  - For contact sizes 95 mm<sup>2</sup> and AWG 4/0, the crimp point must be turned approx. 45° to the vertical (see *Fig. 13*).
2. Mount the slider into the socket housing (refer to *step 6*).
3. Push the pin housing onto the pre-mounted socket housing.
4. Slide the pin contacts with crimped cables – for LV320/400 series together with the auxiliary contacts, if these are used – up to the end stop into the contact cavity of the pin housing.
  - Make sure that the contacts are correctly positioned in the pin housing.
  - For contact sizes 95 mm<sup>2</sup> and AWG 4/0, the crimp point must be turned approx. 45° to the vertical (see *Fig. 13*).

5. Mount the slider into the pin housing (refer to step 6).

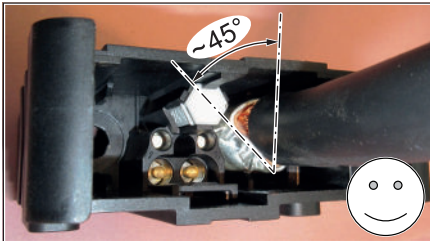
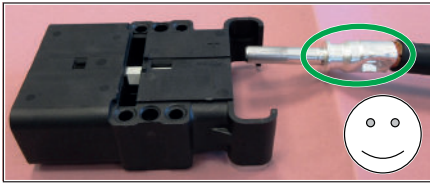

Fig. 13: Correct mounting position of the pin contacts in the pin housing

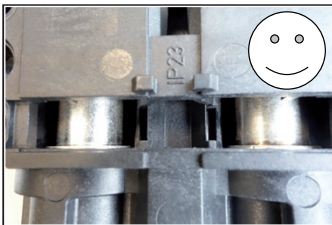

Fig. 14: LV 320/400 correct position of the main and/or auxiliary contacts before the installation of the slider

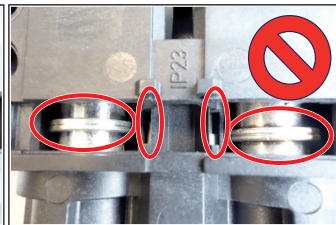

Fig. 15: LV 320/400 wrong position of the main and/or auxiliary contacts before the installation of the slider

## Installing the slider with lock: LV 160/250 and LV 320/400

6. The installation of the sliders should be carried out at room temperature (+25 °C ± 5 °C).

Two-part slider with lock (light grey) LV160/250 S or slider with lock (black) LV320/400 S

The two-part slider with detent consists of a base body "slider" and a sliding part "lock" (refer to Fig. 16/ Fig. 17).

The slider can only be mounted in the unlocked condition. The correct position has to be checked before the mounting (refer to Fig. 18/ Fig. 19)

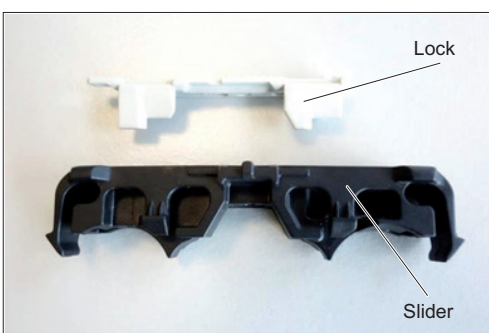

Fig. 16: Two-part slider: View of individual parts of the LV 160/250 S slider

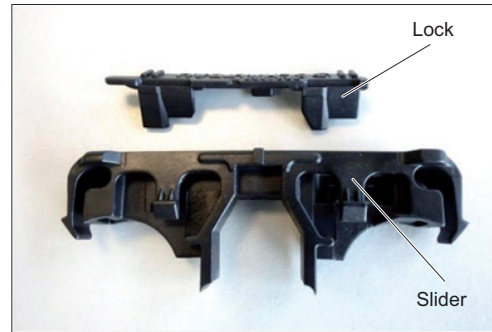

Fig. 17: Two-part slider: View of individual parts of the LV 320/400 S slider

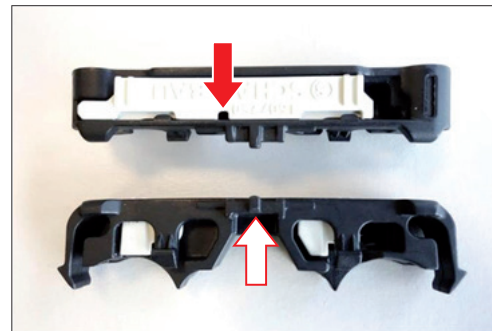

Fig. 18: LV 160/250 S slider with lock in the unlocked condition. The recess of the lock and crossbar of the base body are not overlapping (see arrows).

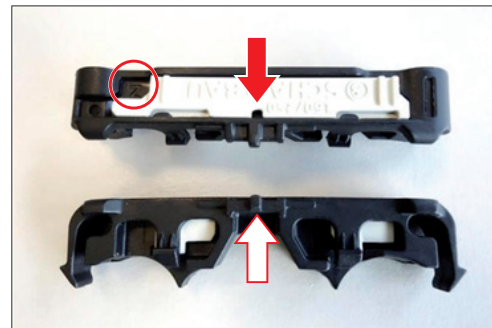

Fig. 19: LV 160/250 S slider with lock in the locked condition. Recess of the lock and crossbar of the base body are overlapping (see arrows). Note: The letter „Z“ or a lock symbol is visible in the locked condition.



Fig. 20: Push in on both sides the slider in the unlocked condition with an application of force on both sides (for the fastening of the main contacts) until it latches.





Fig. 21: Do not push in the slider in the locked condition and not with a centric application of force.

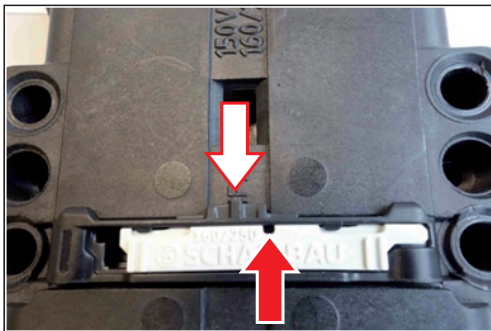

Fig. 22: Slider with lock in the unlocked condition: Recess and crossbar are not overlapping (see arrows).



Fig. 23: Push the slider with a slotted screwdriver by approx. 4 to 5 mm up to the end stop into the locked position so that recess and crossbar are overlapping.

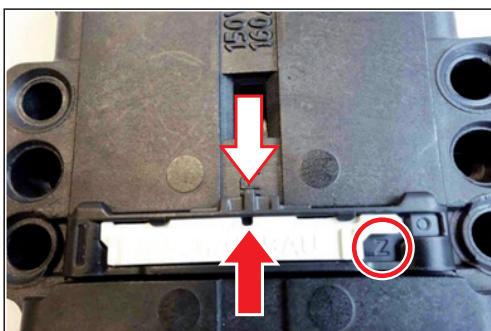

Fig. 24: Slider with lock in the locked condition. Recess and crossbar are now overlapping (see arrows). The letter „Z“ or a lock symbol is visible in the locked condition (see circle).

7. By pulling slightly on the cables of the contacts – for LV320/400 series also on the cables of the auxiliary contacts, where applicable – check whether the contacts are fixed properly.
8. Push the respective housing on the pre-mounted counter housing up to the end stop.

	<p>It is recommended to mate the connectors after the installation of the main contacts and to tighten the stress relief screws only then. Thus, an optimal co-axiality of the main contacts is achieved.</p>
--	---

### Installing the strain relief

9. Screw together the upper and lower clamp of the strain relief so that all cables are uniformly and reliably secured against strain (refer to Fig. 25 and Fig. 26).

The tightening torque for the screws is 1.5 Nm. Take care to use a suitable recessed head insert.

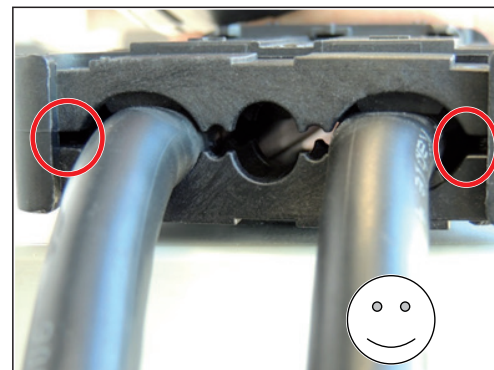

Fig. 25: Uniformly screwed strain relief

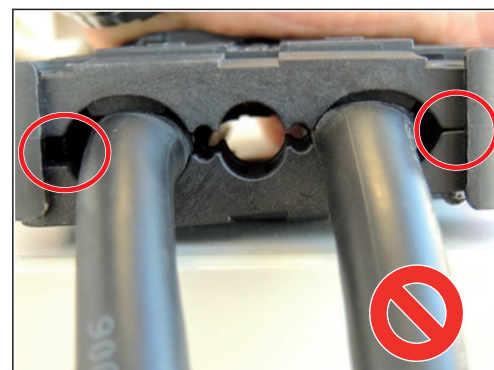

Fig. 26: Non-uniformly screwed strain relief



## 6.2 Dismantling the main contacts



The slider must be removed for the dismantling of the main contacts – for the LV320/400 series also of the auxiliary contacts, where applicable.  
Required tool: Slotted screwdriver, with slot thickness x slot width between 1.0 mm x 5.5 mm and 1.2 mm x 6.5 mm.

### NOTICE

When the lock is not completely in the unlocked position, the slider may be damaged.

1. In the case of the slider with lock, move the lock into the unlocked position up to the end stop before the disassembly.
2. Carefully insert the slotted screwdriver in the position shown in *Fig. 27* up to the end stop.
3. Carefully lift the slider from its seat with a slight rotary movement until it unlatches (refer to *Fig. 28*).



*Fig. 27: Position of the screwdriver for the dismantling of the sliders*



*Fig. 28: Move the lock into the unlocked position up to the end stop. Carefully lift the slider with a rotary movement.*

When using the slider again, pay attention that the 4 latching hooks do still exist (refer to chapter “**7. Maintenance**”/“**7.8 Slider and lock**”). Only use again undamaged sliders!

## 6.3 Installing the pilot and auxiliary contacts

### WARNING



The connectors must not be operated without pilot contact adapter or without air tube adapter with spacer respectively in the socket housing.  
For the fitting position of the connectors make sure that no battery acid gets into the connectors.

### NOTICE

For the LV320/400 series, the auxiliary contacts have to be mounted with the main contacts as the auxiliary contacts are also interlocked with the slider.



For pilot contacts, the pilot contact adapter is already pre-installed in the socket housing.

1. Slide the pilot contact adapter into the plug housing until it latches.
2. After the latching, check by pressing on the pilot contact adapter against the installation direction whether the pilot contact adapter is securely attached.
3. Slide the pilot contacts/auxiliary contacts (with crimped cables) up to the end stop into the contact cavities of the pilot contact adapter or slide auxiliary contacts up to the end stop into the housing respectively.
4. Check whether the contacts are fixed correctly by pulling slightly on the cables of the pilot contacts/auxiliary contacts.

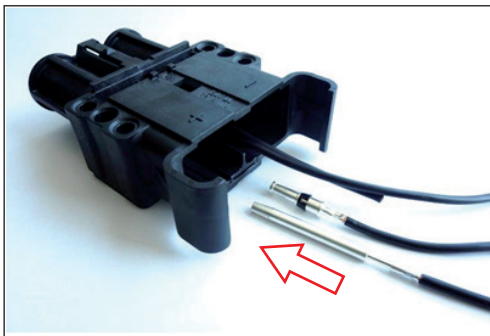
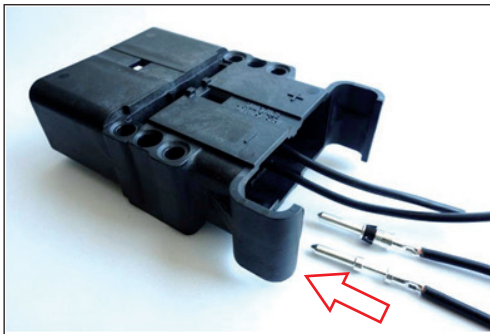
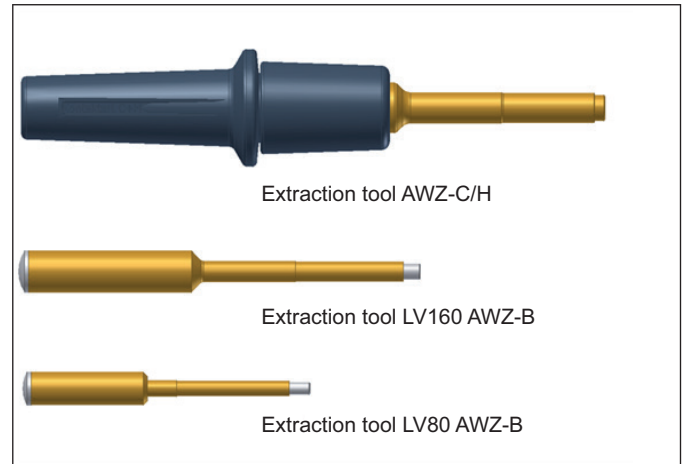

Fig. 29: Installation direction of pilot and auxiliary contacts (upper illustration: pin side, lower illustration: socket side)



1. Fit the suitable extraction tool up to the end stop over the contact. Thus, the clip for the fixation of the contact is unlocked.
2. For extraction tool LV80 AWZ-B and extraction tool LV160 AWZ-B use a tappet to press the contacts out of the contact cavities. For extraction tool AWZ-C/H use a spring-loaded tappet for pressing the contacts out.
3. Pull the contacts completely out of the housing by pulling slightly on the cable.

### 6.4 Dismantling the pilot and auxiliary contacts

i

For the dismantling of pilot and auxiliary contacts special extraction tools are needed.

For the suitable extraction tools corresponding to the kind of contact and the series, refer to the following chart.

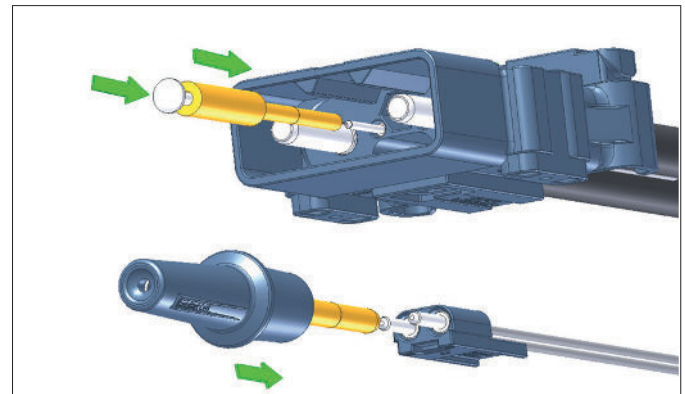



Fig. 30: Dismantling direction of the pilot and auxiliary contacts

Series	Contacts	Tools	
LV80	Pilot contacts	LV80 BBC-2.5-Ag	Extraction tool LV80 AWZ-B
		LV80 SBC-2.5-Ag	
	Auxiliary contacts	LV80 BBC-2.5-Ag	
		LV80 SBC-2.5-Ag	
LV160	Pilot contacts	BCC-2.5-Ag	Extraction tool AWZ-C/H
		SCC-2.5-Ag	
	Auxiliary contacts	LV160 BBC-2.5-Ag	Extraction tool LV160 AWZ-B
		LV160 SBC-2.5-Ag	
LV320 LV500	Pilot contacts	BCC-2.5-Ag	Extraction tool AWZ-C/H
		SCC-2.5-Ag	
	Auxiliary contacts	LV320 BCC-2.5-Ag	The auxiliary contacts are interlocked with the slider.
		LV320 SCC-2.5-Ag	

## 6.5 Installing the air tube adapter

	<b>⚠ WARNING</b>
	<p>When electrolyte fluid gets into the plug connection, its safety is no longer guaranteed. Danger of electric shock, short circuit, explosion and fire!</p> <p>▶ Make sure when using the electrolyte recirculation that the pin housing as well as the socket housing are equipped with the air tube adapter and the spacer.</p> <p>▶ Make sure that the pin housing and socket housing belong to the same series. The air tube interfaces of the older LB-L series are not compatible with the air tube interfaces of the LV series.</p>

	<p>The air tube adapter and the spacer are always enclosed with the socket housing.</p>
--	---

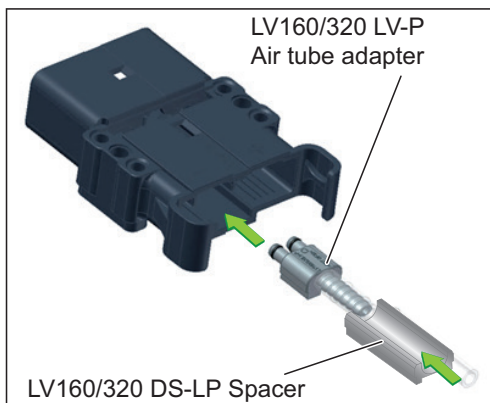

Fig. 31: Air tube adapter pin side

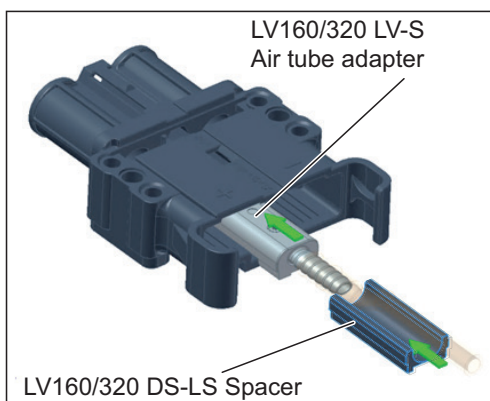



Fig. 32: Air tube adapter socket side

## Air tube specification

The air tubes for the air tube adapter must have the following specification:

- Inside Ø 6 mm
- Wall thickness ≤ 1.5
- Shore-hardness 73

	<b>⚠ WARNING</b>
	<p>In the case of leaky tube adapters, the safety of the connectors is no longer given. Danger of electric shock, short circuit, explosion and fire!</p> <p>▶ Only use tubes whose quality corresponds to the indications in the specification.</p> <p>▶ Don't use fabric tubes and don't use other tubes of lower quality.</p> <p>▶ When using tubes with a larger inside diameter or with a larger wall thickness, only the suitable adapter may be used.</p>

## Use of air tubes according to specification

1. Slide the air tube according to specification (see above) up to the end stop on the air tube adapter.
2. Slide the air tube adapter into the housing until it latches.
3. After that, check whether the air tube adapter is securely attached by pressing on the air tube adapter against the installation direction.
4. Slide the spacer up to the end stop into the pin or socket housing respectively.

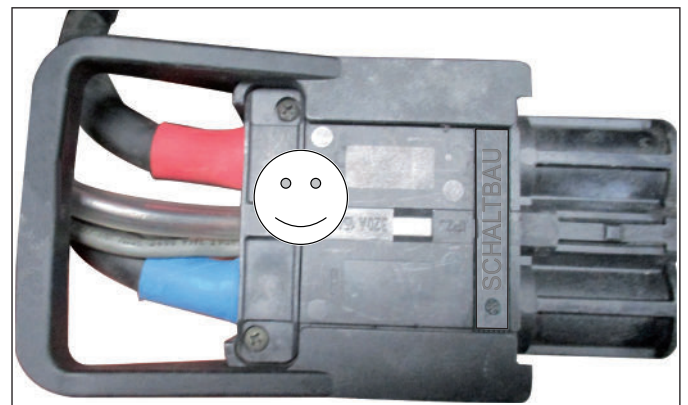

Fig. 33: Air tube corresponding to required specification and with correct laying



Fig. 34: Incorrect laying, fabric tube doesn't correspond to the requirements of the specification

### Use of different air tubes

When using tubes with a larger inside diameter or with a larger wall thickness, only the suitable adapter may be used.

First, a tube according to specification (inside  $\varnothing$  6 mm, wall thickness  $\leq$  1,5 mm, Shore-hardness 73) must be pushed on the air tube adapter and be led out of the pin/socket housing (refer to Fig. 37).

A tube with a larger inside diameter or with a larger wall thickness may then be connected to the end of the tube outside the housing with the suitable adapter.

The connecting piece is an adapter for the fastening of air tubes with an inside diameter of:

- $\varnothing$  6 mm and a wall thickness  $>$  1.5 mm
- $\varnothing$  9 ... 10 mm

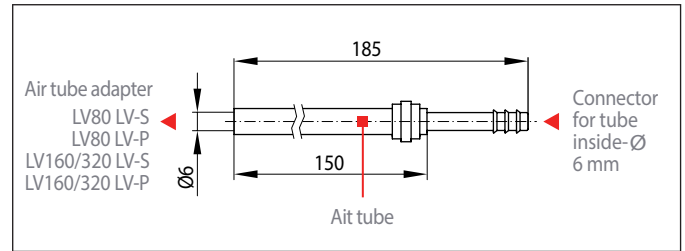

Fig. 35: LV80/160/320 V-S 6/6: Connecting piece (adapter) for 6 mm air tubes with wall thickness  $>$  1.5 mm

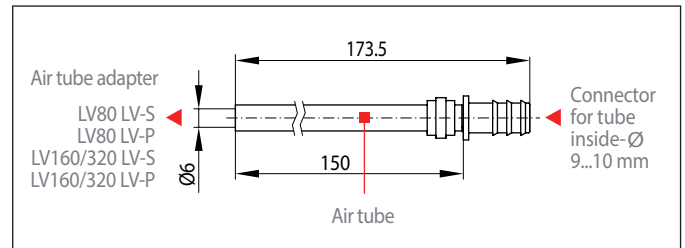

Fig. 36: LV80/160/320 V-S 6/10: Connecting piece (adapter) from 6 mm to 9... 10 mm

1. For the installation of the air tube adapter, refer to steps 1 to 4 in the section "Use of air tubes according to specification" on page 18.
2. Fit the suitable adapter onto the end of the tube.
3. After that, fit the air tube with larger inside diameter or larger wall thickness onto the adapter.

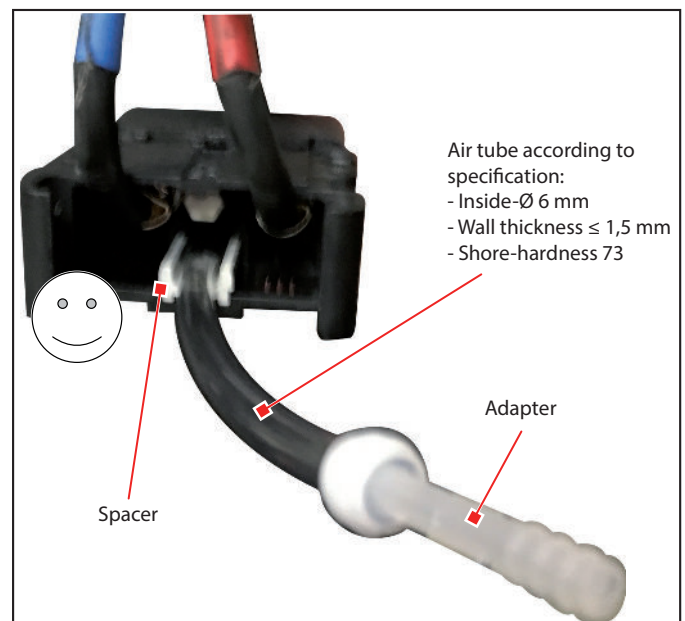

Fig. 37: Air tube according to specification, correctly layed with spacer and adapter; the adapter serves for the connection of tubes with larger inside diameter or larger wall thickness.



## 6.6 Dismantling the pilot or air tube adapter



Required tool: Slotted screwdriver with slot thickness x slot width between 1.0 mm x 5.5 mm to 1.2 mm x 6.0 mm

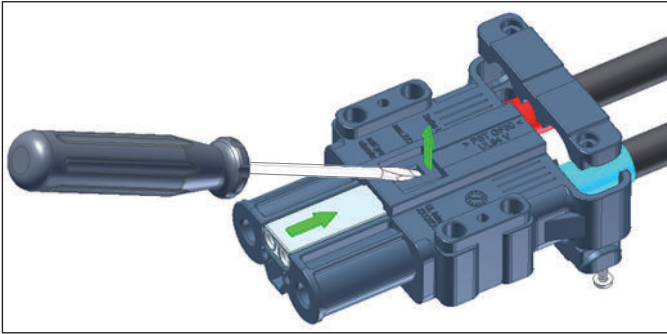

Fig. 38: Dismantling direction of pilot or air tube adapter

1. Slightly lift the lug with the slotted screwdriver approx. 1.5 mm.
2. After that, push the adapter backwards.

## 6.7 Installing the keying plug

### NOTICE

- ▶ When using keying plugs for the voltage coding, the charging and vehicle plug as well as the battery sockets must have the same voltage coding!
- ▶ When using the connectors **without** keying plug, the operator must safeguard measures for the correct use!



For LV80/120 series, first mount the keying plug and then the slider.

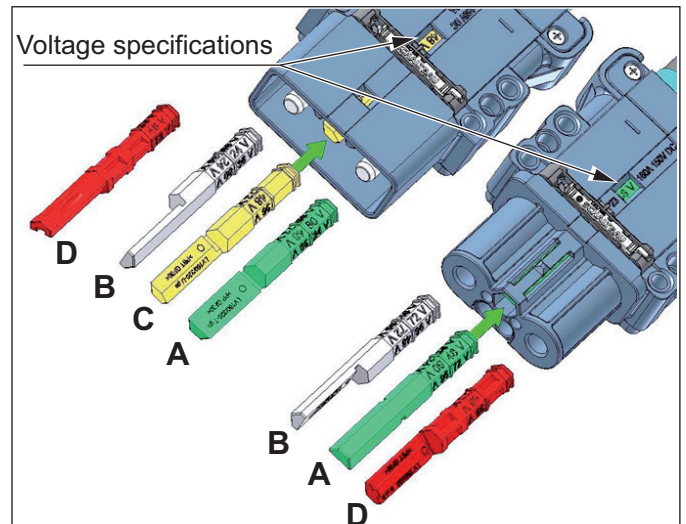

- A Keying plugs for dry-cell battery / charging station (green)
- B Keying plugs for wet-cell battery / charging station (grey)
- C Keying plugs for vehicle plug (yellow)
- D Keying plugs for wet-cell battery / charging station (red), high current capacity (rated current II according to DIN EN 0623-589)

## 6.8 Installation of handles of different models

Handles are available as snap-on and as screwable models.

	<p><b>⚠ WARNING</b></p>
	<p>Don't use the connectors without handle!</p> <ul style="list-style-type: none"> <li>▶ If a snap-on, not screwed handle slips out of the housing, e. g. because of a hard hit on the ground, the handle must be latched again into the fixing holes.</li> <li>▶ A damaged handle must be replaced immediately.</li> </ul>

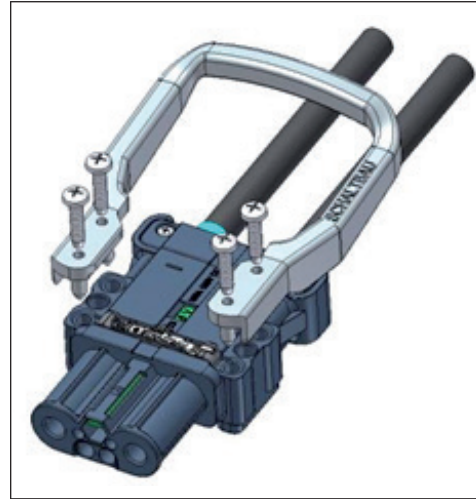

Fig. 41: Screwable handle  
LV...H1/S (black)  
LV...H2/S (red)



Fig. 39: Snap-on handle  
LV80...H1 (black)  
LV80...H2 (red)



Fig. 40: Snap-on handle  
LV160/320 H3 (black)  
LV160/320 H4 (red)

### Installation of snap-on handles

1. Let the snap-on handle latch in the designated fixing holes.
2. For models LV160/250 and LV320/400, the handle may additionally be fixed with 2 screws.  
The tightening torque for the 2 screws is 0.5 Nm.

### Installation of screwable handles

1. Insert the screwable handle into the designated fixing holes.
2. Tighten the 4 fastening screws with suitable recessed head insert.  
The tightening torque for the 4 fastening screws is 0.5 Nm.

## 7. Maintenance

Note the expert knowledge which is essential for carrying out maintenance work, mentioned in chapter “2. **General and safety information**”.

	<p><b>⚠ DANGER</b></p>
	<p>The device and charging connectors contain energized components. There is a risk of electric shock, short circuit, burn and fire!</p> <p>Always observe the following safety regulations before carrying out any work on the device and charging connectors:</p> <ul style="list-style-type: none"> <li>▶ Switch off and secure against restarting</li> <li>▶ Disconnect battery cables</li> <li>▶ Make sure that the parts are deenergized (charging device, battery)</li> <li>▶ Insulate or cover adjacent energized parts like pilot and auxiliary contacts</li> <li>▶ Observe the electric polarity on the connection points of the charging devices as well as of the charging cables</li> </ul>

### 7.1 Maintenance intervals

The condition of the device and charging connectors depends on environmental influences. In order to guarantee the correct and secure operation as well as a prolonged operational life span, regular checks and maintenances have to be carried out according to the following intervals:

- ▶ On a daily basis before startup or with every plugging operation respectively (carried out by the user)
- ▶ Always after an incident, e.g.
  - after inappropriate handling like e.g. after a hard hit of the equipment parts on the floor
  - after contamination with acid or other fluids
  - after an emergency shutdown or after plugging or unplugging on-load (carried out by the service personnel)
- ▶ At least every 1,000 operating hours (carried out by the service personnel)

The results of the checks and maintenances have to be documented for the secure operation of the device and charging connectors. For this purpose, check lists are printed in **chapter 8** where the results of the checks can be documented and then be filed as documents on performed maintenances.

#### NOTICE

After an inappropriate handling, e.g. after a hard hit of the equipment parts on the ground or after contamination with acid or other fluids, the safety of the device and charging connectors is possibly no longer given.

- ▶ After an inappropriate handling all the components of the device and charging connectors and their interface components must be maintained by the service personnel or must be examined for malfunctions respectively and be replaced immediately where applicable.

#### NOTICE

Although disconnecting of the connector when live or under load is permissible under exceptional circumstances or in the case of hazards as an emergency shutdown according to the norm EN 1175-1, it may lead to serious damages.

The safety of the device and charging connectors is then no longer guaranteed.

- ▶ After a plugging or unplugging has been carried out on-load, all the components of the device and charging connectors and their interface components must be maintained by the service personnel or must be checked for malfunctions respectively and be replaced immediately where applicable.
- ▶ The opposite side has also to be checked in the case of a damage (external batteries and charging devices).



**NOTICE**

▶ At least every 1,000 operating hours all the components of the device and charging connectors and their interface components must be maintained or checked for malfunctions through a visual check respectively and be replaced immediately where applicable.

## 7.2 Daily visual and functional check by the user

The user of the industrial truck must do a visual and functional check of all components of the device and charging connectors on a daily basis, before the startup or with every plugging operation respectively.

A visual and functional check is also always required after an incident, e.g.

- after an inappropriate handling like e.g. after a hard hit of the equipment parts on the ground
- after contamination with acid or other fluids
- after an emergency shutdown or disconnecting of the connectors under load

In these cases, further maintenance measures might be required which must be carried out by the service personnel.

**NOTICE**

If the check reveals damages to the plug connection, the safety of the connectors is no longer guaranteed.

- ▶ Don't put damaged device and charging connectors into operation.
- ▶ Immediately replace all damaged parts.

Components of the plug connection	Interval		Checks to be carried out	Measures
	Before startup on a daily basis	after an incident <sup>1,2,3</sup>		
Complete device and charging connectors	X	X <sup>1,2,3</sup>	<ul style="list-style-type: none"> <li>▶ The plugging and unplugging by hand must be possible without an increased effort</li> <li>▶ Gap between collar of the pin and socket housing ≤ 2 mm (also refer to section "7.4 Plugging operation")</li> </ul>	When complete plugging (gap ≤ 2 mm) or unplugging is not possible without an increased effort: <ul style="list-style-type: none"> <li>▶ Immediately replace the complete device and charging connectors. It is <b>not</b> sufficient to replace only one half of the plug connection!</li> </ul>
Main contacts	X	X <sup>1,3</sup>	Visual check of the main contacts for: <ul style="list-style-type: none"> <li>▶ Material covering and/or removal</li> <li>▶ Contamination, discolouration due to dust, abrasion and media like e.g. acid (also refer to section "7.5 Main contacts")</li> </ul>	In the case of only slight contamination: <ul style="list-style-type: none"> <li>▶ Remove dirt residue-free</li> </ul> In the case of material covering and/or removal, contamination, discolouration or abrasion: <ul style="list-style-type: none"> <li>▶ Immediately replace the complete device and charging connectors. It is <b>not</b> sufficient to replace only one half of the plug connection!</li> </ul>

<sup>1</sup> After an emergency shutdown or plugging or unplugging on-load  
<sup>2</sup> After an inappropriate handling like e.g. after a hard hit of the equipment parts on the ground  
<sup>3</sup> After contamination with acid or other fluids

Components of the plug connection	Interval		Checks to be carried out	Measures
	Before startup on a daily basis	after an incident 1,2,3		
Main contacts and keying plugs	X	X <sup>1,2</sup>	Visual check of notches and position of the main contacts and keying plugs: <ul style="list-style-type: none"> <li>▶ The position of the pin and socket contacts as well as of the keying plugs in relation to the housing must correspond to the indications in the drawings under section <b>"7.6 Position of the main contacts and keying plugs"</b>.</li> </ul>	When the position of the pin and socket contacts and/or the keying plugs differs from the indications in the drawings: <ul style="list-style-type: none"> <li>▶ Immediately replace the complete device and charging connectors. It is <b>not</b> sufficient to replace only one half of the plug connection!</li> </ul>
Pin and socket housing, clamps, strain relief, handles, pilot contact adapter, air tube adapter, adapters and keying plugs	X	X <sup>1,2,3</sup>	Visual check of the components for: <ul style="list-style-type: none"> <li>▶ Breaks</li> <li>▶ Cracks and deformations</li> <li>▶ Contamination, discolouration due to dust, abrasion and media like e.g. acid</li> <li>▶ correctly latched handles</li> <li>▶ correctly latched pilot or air tube adapters</li> <li>▶ existing keying plugs</li> </ul> (also refer to sections <b>"7.7 Pin and socket housing"</b> , <b>"7.10 Clamps (strain relief)"</b> , <b>"7.11 Handles LV (snap-on, screwable)"</b> , <b>"7.12 Pilot contact adapter and air tube adapter"</b> , <b>"7.15 Keying plugs"</b> )	In the case of only slight contamination: <ul style="list-style-type: none"> <li>▶ Remove dirt residue-free</li> </ul> In the case of damages, contamination, discolouration or abrasion: <ul style="list-style-type: none"> <li>▶ Make the service personnel immediately replace damaged parts.</li> </ul>
Slider, lock	X	X <sup>2</sup>	Visual check of slider, lock for: <ul style="list-style-type: none"> <li>▶ Breaks</li> <li>▶ Cracks and deformations</li> <li>▶ existence of slider and lock</li> <li>▶ slider latched on both sides</li> <li>▶ locked position of the lock</li> </ul> (also refer to section <b>"7.8 Slider and lock"</b> )	<ul style="list-style-type: none"> <li>▶ Make the service personnel immediately replace missing parts.</li> <li>▶ Make the service personnel immediately replace damaged parts.</li> <li>▶ Let the slider latch on both sides where applicable.</li> <li>▶ Bring lock into locked position where applicable.</li> </ul>
If there is an electrolyte recirculation: <ul style="list-style-type: none"> <li>- air tube adapter and spacer (socket housing)</li> <li>- air tube adapter and spacer (pin housing)</li> <li>- connector (air tube adapter)</li> </ul>	X	X <sup>1,2,3</sup>	Visual check of the components for: <ul style="list-style-type: none"> <li>▶ damages to the sealing contour</li> <li>▶ breaks</li> <li>▶ cracks and deformations</li> <li>▶ contamination, discolouration due to dust, abrasion and media like e.g. acid</li> </ul> also refer to section <b>"7.14 Electrolyte recirculation"</b>	<ul style="list-style-type: none"> <li>▶ Make the service personnel immediately replace damaged parts.</li> </ul>

Components of the plug connection	Interval		Checks to be carried out	Measures
	Before startup on a daily basis	after an incident <sup>1,2,3</sup>		
Cables	X	X <sup>1,2,3</sup>	Visual check of the cable insulations for: ► damages ► carbonization ► cracks and strippings ► residues of acid also refer to section <b>"7.16 Cables"</b>	► Make the service personnel immediately replace damaged cables.

<sup>1</sup> After an emergency shutdown or plugging or unplugging on-load  
<sup>2</sup> After an inappropriate handling like e.g. after a hard hit of the equipment parts on the ground  
<sup>3</sup> After contamination with acid or other fluids

### 7.3 Visual/functional check and maintenance by the service personnel

The service personnel has to carry out regular checks and maintenances of the device and charging connectors according to the following intervals:

- Always after an incident, e.g.
  - after an inappropriate handling like e.g. after a hard hit of the equipment parts on the ground
  - after contamination with acid or other fluids
  - after an emergency shutdown or plugging or unplugging on-load
- At least every 1,000 operating hours

In addition to the visual/functional checks as under **"7.2 Daily visual and functional check by the user"**, the service personnel must carry out the following checks/maintenances.

Components of the plug connection	Interval		Checks/Maintenances to be carried out	Measures
	after an incident <sup>1,2,3</sup>	every 1,000 operating hours		
Housings and cables	X <sup>1,2</sup>	X	► Check heating of housings and cables during operation. The rise in temperature of housings and cables compared to the ambient temperature must be ≤ 65 K. (Also refer to sections <b>"7.7 Pin and socket housing"</b> as well as <b>"7.16 Cables"</b> )	When the heating is more than 65 K: ► Immediately replace the complete device and charging connectors. It is <b>not</b> sufficient to replace only one half of the plug connection!
Main contacts	-	X	► Lubricate the main contacts every 1,000 plugging cycles or every 1,000 operating hours respectively with copper contact grease. (Also refer to section <b>"7.5 Main contacts"</b> )	

Components of the plug connection	Interval		Checks/Maintenances to be carried out	Measures
	after an incident <sup>1,2,3</sup>	every 1,000 operating hours		
Heat-shrink tubings (if existent)	X <sup>1,3</sup>	X	<ul style="list-style-type: none"> <li>▶ Check proper condition of the heat-shrink tubings.</li> <li>▶ Check heat-shrink tubings for adherence to the dimensions according to the illustration in section "7.9 Heat-shrink tubings".</li> </ul>	<ul style="list-style-type: none"> <li>▶ Immediately replace faulty components.</li> </ul>
Pilot contact adapter, air tube adapter, spacer in socket housing and pin housing, adapter, air tube	X <sup>1,3</sup>	X	<ul style="list-style-type: none"> <li>▶ Check whether all components are existent and are in an undamaged condition.</li> <li>▶ Quality and dimensions of the air tube (also refer to section "7.12 Pilot contact adapter and air tube adapter")</li> </ul>	<ul style="list-style-type: none"> <li>▶ Immediately replace missing components</li> <li>▶ Immediately replace faulty components.</li> </ul>

<sup>1</sup> After an emergency shutdown or plugging or unplugging on-load

<sup>2</sup> After an inappropriate handling like e.g. after a hard hit of the equipment parts on the ground

<sup>3</sup> After contamination with acid or other fluids

## 7.4 Plugging operation

**WARNING**

The plugging and unplugging of device and charging connectors under electrical voltage generates electric arcs. Risk of electric shock!

- ▶ Always switch off the charging device before plugging or unplugging the connectors.

**WARNING**

The plugging and unplugging of the device and charging connectors under electrical voltage generates electric arcs. Risk of fire through overheating!

- ▶ Always switch off the charging device before plugging or unplugging the connectors.

**WARNING**

The plugging and unplugging of the device and charging connectors under electrical voltage generates electric arcs. Risk of explosion!

- ▶ Never plug or unplug the device and charging connectors on-load near to explosive substances or to ignition sources of any kind.
- ▶ Always switch off the charging device before plugging or unplugging the connectors.

In order to guarantee a safe operation of the current transmission and of the electrolyte recirculation (leak-tightness), the device and charging connectors must be completely pluggable by hand. Completely plugged means that the gap between the collar of the pin housing and the socket housing has a maximum of 2 mm.

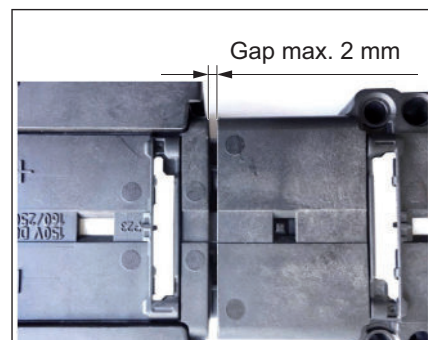

Fig. 42: Permissible gap between the collar of the pin housing and the socket housing

**NOTICE**

If a complete plugging by hand is not possible without an increased effort, the device and charging connectors (pin and socket) must be replaced immediately and completely. It is not sufficient to replace only one half of the plug connection!

### 7.5 Main contacts

Although a load disconnection is permissible under exceptional circumstances or in the case of hazards as an emergency shutdown according to the norm EN 1175-1, it may lead to serious damages.

Depending on the frequency of plugging under conditions of an emergency shutdown or with an overload respectively, material is coated or stripped on the contacts. There is a formation of material covering at the contact zone. The transition resistance rises continuously and an inadmissible heating of the device and charging connectors as well as of the connected cable is the consequence. There is a risk of fire! Increased insertion forces may be the consequence or a complete plugging may become impossible.

After every inappropriate handling at the latest, after every plugging and unplugging on-load, after every emergency shutdown as well as additionally at least every 1,000 operating hours the following items must be checked:

- ▶ Can the device and charging connectors be plugged and/or unplugged by hand only with an increased effort?
- ▶ Can the two halves of the connection not be completely plugged by hand (refer to **"Fig. 42: Permissible gap between the collar of the pin housing and the socket housing"**)?
- ▶ Is there a heating > 65K compared to the ambient temperature of the housing or the cables during operation?
- ▶ Do the main contacts show material covering and/or material removal, contamination or discoloration by dust, abrasion and media like e.g. acid when checked visually?
- ▶ Can the main contacts be moved or shifted by pulling slightly on the cables?
- ▶ Does the position of the pin and socket contacts in relation to the housing differ from the chart (refer to **Fig. 47** and **Fig. 48**)?

**NOTICE**

Device and charging connectors to which one of the before mentioned items applies, have to be replaced immediately!

- ▶ To increase the service life, the main contacts should be lubricated with copper contact grease every 1,000 mating cycles or at least every 1,000 operating hours.



Fig. 43: Right contact with material covering or removal on pin contact

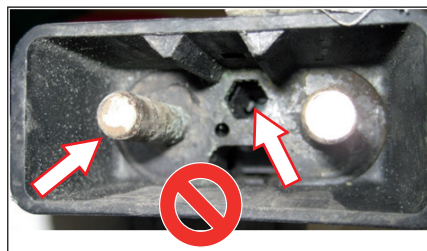

Fig. 44: Left pin contact contaminated due to acid exposure, keying plug is missing



Fig. 45: Socket contact with material covering or removal



Fig. 46: Socket contact contaminated due to acid exposure



## 7.6 Position of the main contacts and keying plugs

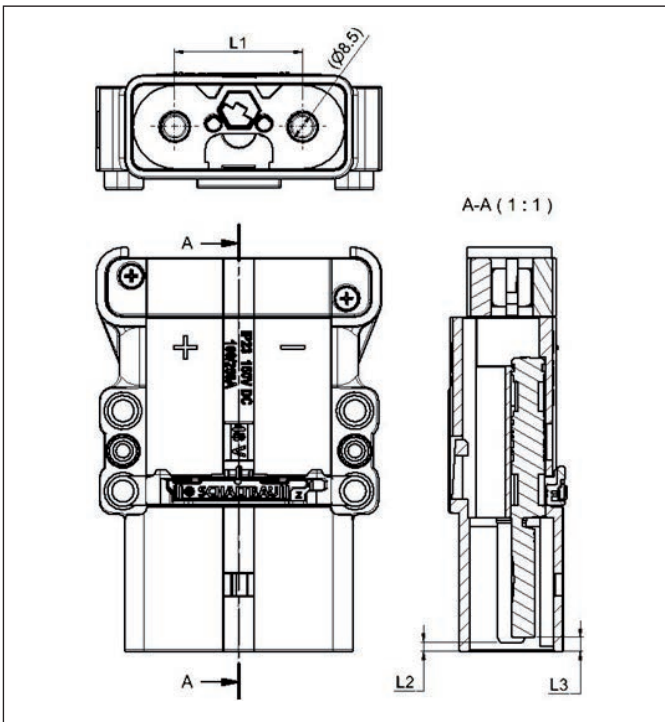

Fig. 47: Position of the pin contacts, keying plugs

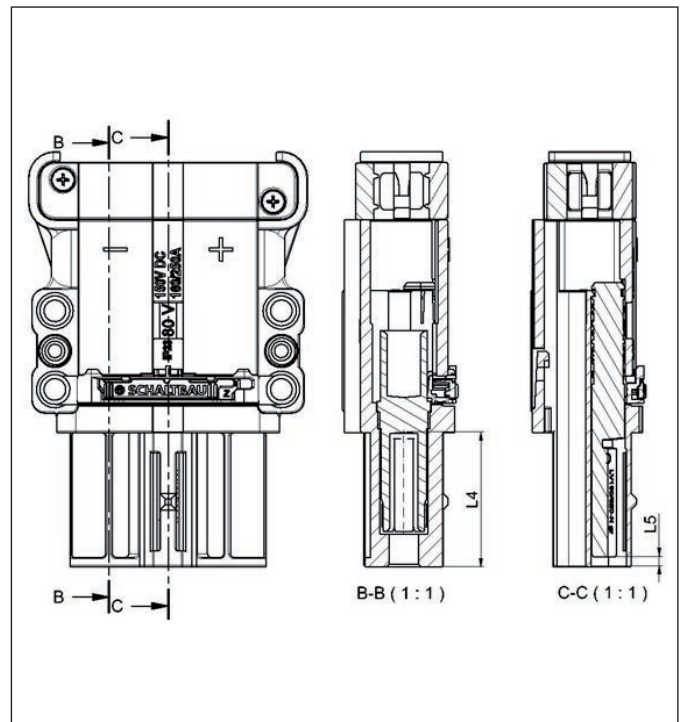

Fig. 48: Position of the socket contacts, keying plugs

Series	L1 [mm], ± 0.8	L2 [mm], 0/+1.5	L3 [mm], ± 1.55	L4 [mm], ± 2.2	L5 [mm], ± 1
LV80/120	32	2	1.5	26.5	1.5
LV160/250	38		4	40	3
LV320/400	41		10	48.9	

## 7.7 Pin and socket housing

Inappropriate handling of the device and charging connectors, e.g. by a hard hit on the ground, may lead to damages of the pin and socket housing, especially in the area of the strain relief.

- ▶ Check pin and socket housing for damages like breaks, cracks, deformations, discolourations and contamination.

### NOTICE

If the pin and socket housing show breaks, cracks or deformations, contaminations or discolourations by dust, abrasion or media/fluids like e.g. acid, the faulty components have to be replaced immediately!

- ▶ Check heating of pin and socket housing (as well as of the cables) during the operation. The rise in temperature of the housings (and cables) compared to the ambient temperature must be  $\leq 65$  K.

### NOTICE

When the heating is more than 65 K compared to the ambient temperature:

- ▶ Immediately replace the complete device and charging connectors. It is **not** sufficient to replace only one half of the plug connection!

### 7.8 Slider and lock

The slider has the function of holding the main contacts and prevents the contacts from being touched during operation.

Inappropriate handling of the device and charging connectors, e.g. by a hard hit on the ground, may lead to breaks, cracks and deformations or to a dropping of the slider or may alter the position of the slider respectively. After an inappropriate handling as well as additionally at least every 1,000 operating hours, the following must be checked:

- ▶ Is the slider existent in the device and charging connectors (refer to Fig. 49 and Fig. 50).
- ▶ Is the slider (with lock) securely attached in the device and charging connectors.
- ▶ Check fixation of the slider by slightly levering the slider with a slotted screwdriver, with slot thickness x slot width between 1.0 mm x 5.5 mm to 1.2 mm x 6.5 mm (refer to Fig. 51 and Fig. 52). The slider must be latched on both sides.
- ▶ Check whether the lock is in the locked position. The lock has to be locked again if necessary.
- ▶ If the slider shows breaks, visible cracks or deformations (refer to Fig. 53 to Fig. 56), contamination or discolouration by dust, abrasion and media like e.g. acid, the faulty components have to be replaced immediately!

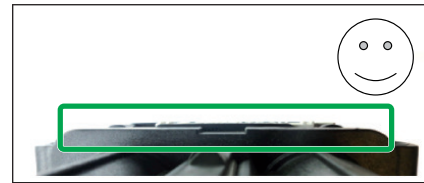

Fig. 51: Slider is in position and in latched position. O.k.! Slider is mounted parallel to the housing.



Fig. 52: Slider not parallel to the housing and thus not in the correct position. Left side of the slider is not latched.

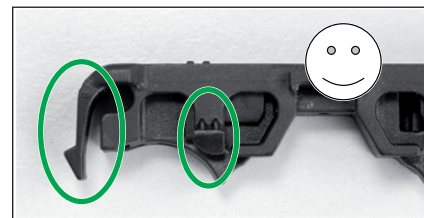

Fig. 53: All latching hooks (2 items per half) are o.k. ! Only one half is illustrated here.

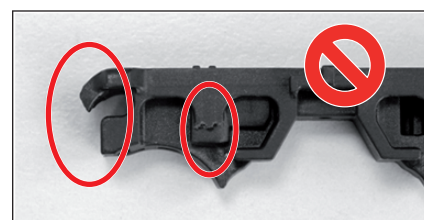

Fig. 54: Two latching hooks are broken. The slider is not o.k. as soon as one of the four latching hooks is missing or is broken or if the bearing surface is damaged.

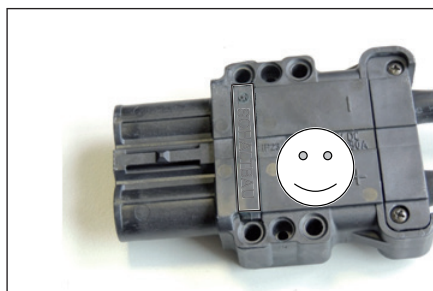

Fig. 49: Slider existent in the plug connection. O.k.!

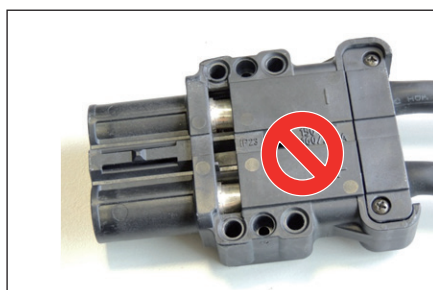

Fig. 50: Slider not existent in the plug connection. The charging connector device must not be used in this condition!





Fig. 55: LV 320/400 S slider with latching hooks that are intact



Fig. 56: LV 320/400 S slider with damaged latching hooks

### NOTICE

When one of the four latching hooks is missing or is broken and/or the bearing surfaces of the slider are damaged, the slider must be replaced immediately.

## 7.9 Heat-shrink tubings

- ▶ Check the proper condition of the heat-shrink tubings.
- ▶ Check the heat-shrink tubings for adherence to the dimensions according to the following illustrations.

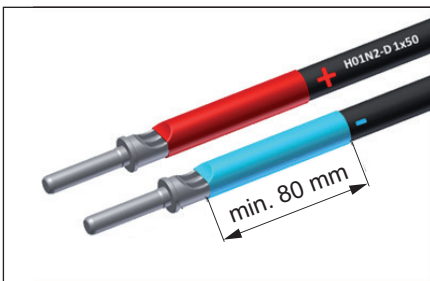

Fig. 57: Position and dimensions for the heat-shrink tubing from 16 mm<sup>2</sup> to AWG 4/0 in centre to the crimping; length of heat-shrink tubing at least 80 mm

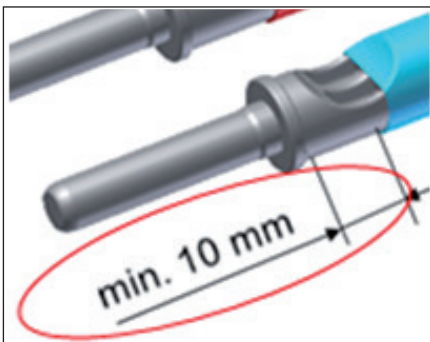

Fig. 58: Minimum distance between heat-shrink tubing and the collar of the contacts

## 7.10 Clamps (strain relief)

- ▶ Check clamps for breaks, cracks, deformations, contamination or discolouration by dust, abrasion and media like e.g. acid.
- ▶ Retighten the screws of the clamp (strain relief) with a tightening torque of 1.5 Nm.

### NOTICE

Immediately replace faulty clamps (strain reliefs).

## 7.11 Handles LV (snap-on, screwable)

### NOTICE

Faulty or missing handles must be replaced immediately.

### NOTICE

When plugging or unplugging the connectors, do **not** pull or push the cables. When the handle is missing, the connectors must be handled directly on the housing.

- ▶ Check the handles for malfunctions like breaks, cracks and deformations.

For snap-on handles:

- ▶ Check snap-on handle for correct and secure attachment.
- When a snap-on handle has slipped out of the housing (e.g. after a hard hit on the ground), let it latch again in the fixation holes.

For screwable handles:

- ▶ Check screwable handle for correct and secure attachment.
- ▶ Retighten the 4 fastening screws with a tightening torque of 0.5 Nm.

## 7.12 Pilot contact adapter and air tube adapter

### NOTICE





The connectors may only be operated when the socket housing is equipped with pilot contact adapter or air tube adapter including spacer..

- ▶ Check whether the pilot contact adapter or the air tube adapter including spacer respectively are existent in the socket housing!

### 7.13 Pilot and auxiliary contacts (pin, socket)

- ▶ Check by slightly pulling on the cables whether the pilot or the auxiliary contact is latched correctly.

### 7.14 Electrolyte recirculation

	<b>WARNING</b>
  	<p>Leaking media like e.g. acid (condensate of the battery electrolyte fluid) may strongly impair the current transmission and the plugging and unplugging forces of the charging connectors. Risk of electric shock, short circuit, explosion and fire!</p> <ul style="list-style-type: none"> <li>▶ If the following components show damages at the sealing contour, breaks, cracks, deformations, contaminations or discolourations by dust, abrasion oder media/fluids like e.g. acid, the faulty components have to be replaced immediately!</li> </ul>

The following components have to be checked for leak-tightness and damages.

- ▶ Air tube adapter and spacer (socket housing)
- ▶ Air tube adapter and spacer for LV160/250 and LV320/400 (pin housing)
- ▶ Connecting piece (extra air tube adapter)
- ▶ Check additionally whether the connecting tube has the correct quality and dimensions for a secure and tight connection and whether the connector was used properly. Also refer to section *“Use of air tubes according to specification” on page 18*

### 7.15 Keying plugs

<b>NOTICE</b>
<ul style="list-style-type: none"> <li>▶ When using keying plugs for the voltage coding, the charging and vehicle plug as well as the battery sockets must show the same voltage coding!</li> <li>▶ When using the connectors <b>without</b> keying plug, the operator must safeguard measures for the correct use!</li> </ul>

- ▶ Check the keying plugs for damages like breaks, cracks, deformations, discolourations and contamination.
- ▶ Check the position and the secure attachment of the keying plugs.
- ▶ Check whether the charging and vehicle plug as well as the battery sockets show the correct voltage coding. Immediately replace wrong keying plugs!

<b>NOTICE</b>
<p>When the keying plugs show damages in the plugging area, breaks, cracks, deformations or contaminations, the faulty components have to be replaced immediately!</p>

### 7.16 Cables

Check cable insulations for:

- ▶ Damages
- ▶ Carbonization or deposits of acid
- ▶ Cracks and strippings

<b>NOTICE</b>
<p>When the cables show damages or strippings of the cable insulation and/or a carbonised insulation of the cables or deposits of acid, the faulty components have to be replaced immediately!</p>

Check the heating of the cables (as well as of pin and socket housing) during operation. The rise in temperature of the cables (and housings) compared to ambient temperature must be  $\leq 65$  K.

<b>NOTICE</b>
<p>When the heating is more than 65 K compared to ambient temperature:</p> <ul style="list-style-type: none"> <li>▶ Immediately replace the complete device and charging connectors. It is <b>not</b> sufficient to replace only one half of the plug connection!</li> </ul>

## 8. Check lists



These check lists do not substitute the reading and the observation of the crimping, installation and maintenance instructions. They are only an assistance for the safe operation and use of the industrial truck in relation to the device and charging connectors.

### 8.1 Check list for the user of the industrial truck

Checks to be carried out	Criterion	Before startup on a daily basis	After an incident <sup>1,2,3</sup>	Done
1) Check the complete plugging by hand of the device and charging connectors.	Gap 2 mm at most	Yes	Yes <sup>1,2,3</sup>	<input type="checkbox"/>
2) Check the main contacts through a visual check for material covering and/or material removal, contamination or discolouration due to dust, abrasion and media like e.g. acid.	No faults visible	Yes	Yes <sup>1,3</sup>	<input type="checkbox"/>
3) Check notches and position of the main contacts and keying plugs.	Dimensions according to chart observed	Yes	Yes <sup>1,2</sup>	<input type="checkbox"/>
4) Check pin and socket housings, sliders, clamps, handles, pilot adapters, air tube adapters and spacer, connecting pieces (extra air tube adapters) and keying plugs through a visual check for breaks, visible cracks and deformations, contaminations and discolourations due to dust, abrasion and media like e.g. acid.	No faults visible, handle, pilot or air tube adapter latched	Yes	Yes <sup>1,2,3</sup>	<input type="checkbox"/>
5) Check if notches of the slider are existent and in proper condition. For slider with lock check optionally the position of the sliding part of the lock.	Latched on both sides, lock interlocked	Yes	Yes <sup>2</sup>	<input type="checkbox"/>
6) If there is an electrolyte recirculation existent, check air tube adapter and spacer (of socket housing), air tube adapter and spacer (of pin housing), and connecting piece (extra air tube adapter) for damages on the sealing contour, breaks, visible cracks and deformations, contaminations or discolourations by dust, abrasion or media/fluids like e.g. acid.	No faults visible	Yes	Yes <sup>1,2,3</sup>	<input type="checkbox"/>
7) Check the insulation of the cables (cable sheath) for damages, carbonization, residues of acid, cracks and strippings.	No faults visible	Yes	Yes <sup>1,2,3</sup>	<input type="checkbox"/>

<sup>1</sup> After an emergency shutdown or plugging and unplugging on-load

<sup>2</sup> After an inappropriate handling, e.g. after a hard hit of the equipment parts on the ground

<sup>3</sup> After contamination with acid or other fluids

## 8.2 Check list for the service personnel of the industrial truck

Checks to be carried out	Criterion	Service personnel: After an incident <sup>1,2,3</sup>	Service personnel: At least after 1,000 operating hours	Done
1) Check the complete plugging by hand of the device and charging connectors.	Gap 2 mm at most	Yes <sup>1,2,3</sup>	Yes	<input type="checkbox"/>
2) Check heating during operation. The rise in temperature of housing and cables must not be more than 65 K compared to the ambient temperature.	Heating of the housing and the cables ≤ 65K	Yes <sup>1,2</sup>	Yes	<input type="checkbox"/>
3) Check the main contacts through a visual check for material covering and/or material removal, contamination or discolouration due to dust, abrasion and media like e.g. acid.	No modifications visible	Yes <sup>1,3</sup>	Yes	<input type="checkbox"/>
4) Lubricate the main contacts with copper contact grease.	Every 1,000 plugging cycles or every 1,000 operating hours respectively	No	Yes	<input type="checkbox"/>
5) Check notches and position of the main contacts and keying plugs.	Dimensions according to chart observed	Yes <sup>1,2</sup>	Yes	<input type="checkbox"/>
6) Check the pin and socket housings, sliders, clamps, handles, pilot adapters, air tube adapters and spacers, connecting pieces (extra air tube adapters) and keying plugs through a visual control for breaks, visible cracks and deformations, contaminations and discolourations due to dust, abrasion and media like e.g. acid.	No faults visible, handle, pilot or air tube adapter latched	Yes <sup>1,2,3</sup>	Yes	<input type="checkbox"/>
7) Check if notches of the slider are existent and in proper condition. Check position of the lock.	Latched on both sides, lock interlocked	Yes <sup>2</sup>	Yes	<input type="checkbox"/>
8) If heat-shrink tubings are existent, check their proper condition.	Dimensions according to chart observed	Yes <sup>1,3</sup>	Yes	<input type="checkbox"/>
9) Check existence of pilot contact adapter or air tube adapter including spacer respectively in the socket housing and in the pin housing!	Existence	Yes <sup>1,2,3</sup>	Yes	<input type="checkbox"/>
10) If there is an electrolyte recirculation existent, check air tube adapter and spacer (of socket housing), air tube adapter with spacer (of pin housing), and connecting piece (extra air tube adapter) for damages on the sealing contour, breaks, visible cracks and deformations, contaminations oder discolourations by dust, abrasion oder media/fluids, like e.g. acid. Check the connecting tube for correct quality and dimensions to ensure secure and tight connection. If applicable, check the connecting piece for leak-tightness at the connections.	No faults visible	Yes <sup>1,2,3</sup>	Yes	<input type="checkbox"/>
11) Check the insulation of the cables (cable sheath) through a visual check for damages, carbonization, residues of acid, cracks and strippings.	No faults visible	Yes <sup>1,2,3</sup>	Yes	<input type="checkbox"/>

<sup>1</sup> After an emergency shutdown or plugging and unplugging on-load.

<sup>2</sup> After an inappropriate handling, e.g. after a hard hit of the equipment parts on the ground

<sup>3</sup> After contamination with acid or other fluids

## 9. List of spare parts

The latest version of the spare parts can be downloaded from <https://www.schaltbau.com/en/media-library/>

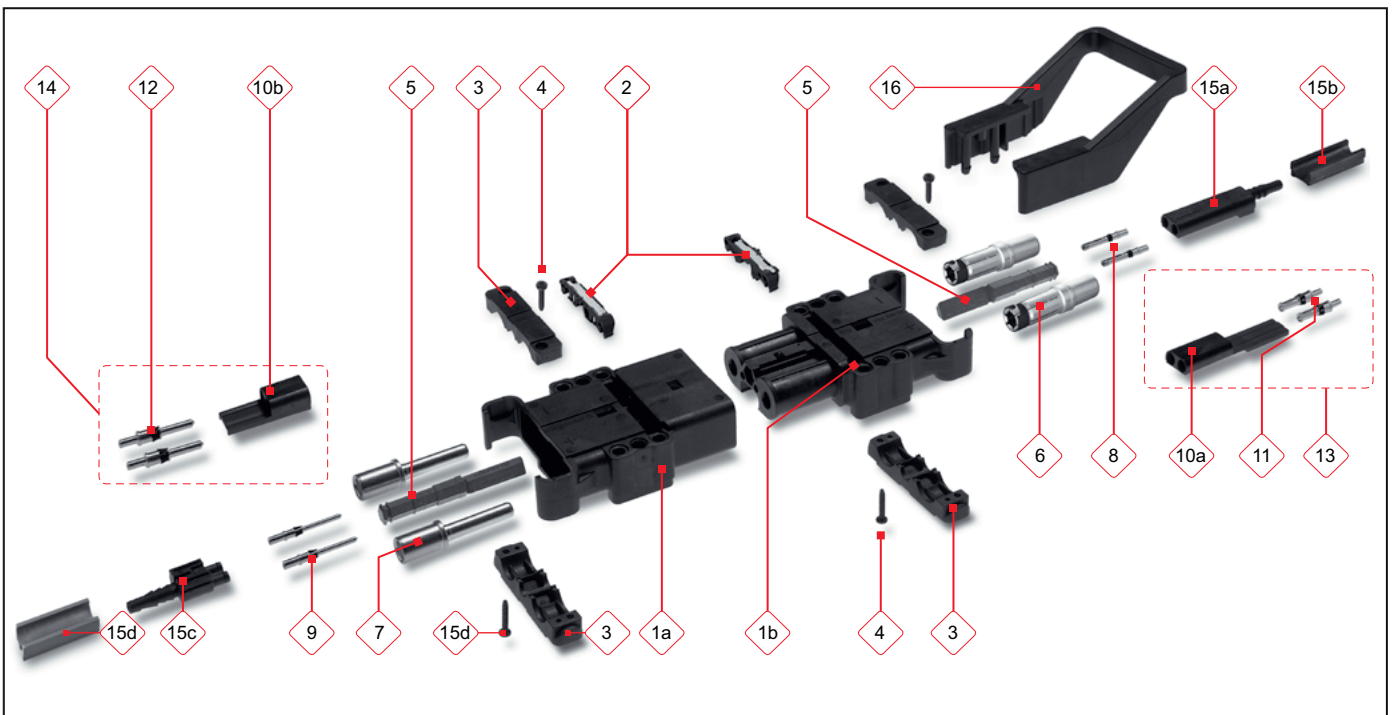

Fig. 59: Overview of spare parts LV series

Item	Designation		Ordering code			Description
			LV320/400	LV160/250	LV80/120	
1a 1b	Plug shell Receptacle shell		LV320/400 G-P LV320/400 G-SP LV320/400 G-SL	LV160/250 G-P LV160/250 G-SP LV160/250 G-SL	LV80/120 G-P LV80/120 G-SP LV80/120 G-SL	Shell to enclose pin contacts Receptacle with pre-assembled item 10a Receptacle with added item 15a
2	Slider	black grey green	LV320/400 S	LV160/250 S	LV80 S	Locks main contacts in place (LV320 also auxiliary contacts)
3	Clamp		LV320 D	LV160 D	LV 80 D	2x for strain relief
4	Screw for clamp		SC 3.5x19 SC 3.5x25	SC 3.5x16 ---	SC 3.5x16 ---	2x self-tapping screw for strain relief: Wire gauge AWG 1/0 max. (50 mm <sup>2</sup> ) Wire gauge AWG 3/0 / AWG 4/0 (70 mm <sup>2</sup> /95 mm <sup>2</sup> )
5	Keying plug	red red grey green yellow	LV250/400 NrS LV250/400 NrP LV160/320 Ngr LV160/320 Tgn LV160/320 Uge		LV120 NrS LV120 NrP LV80 Ngr LV80 Tgn LV80 Uge	for battery receptacle, high amperage, wet-cell for charging plug, high amperage, wet-cell for battery receptacle/charging plug, wet-cell for battery receptacle/charging plug, dry-cell for vehicle plug
6	Main contact (socket)	AWG 4/0 (120 mm <sup>2</sup> ) 95 mm <sup>2</sup> AWG 3/0 (70 mm <sup>2</sup> ) AWG 1/0 (50 mm <sup>2</sup> ) AWG 4 (25 mm <sup>2</sup> )	LV500 S10/AWG4/0 LV320 S10/95 LV320 S10/70 LV320 S10/50 ---	---	---	2x for battery receptacle AWG 4/0 2x for battery receptacle 95 mm <sup>2</sup> 2x for battery receptacle AWG 3/0 2x for battery receptacle AWG 1/0 2x for battery receptacle AWG 4
7	Main contact (pin)	AWG 4/0 (95 mm <sup>2</sup> ) 95 mm <sup>2</sup> AWG 3/0 (70 mm <sup>2</sup> ) AWG 1/0 (50 mm <sup>2</sup> ) AWG 4 (25 mm <sup>2</sup> )	LV500 P10/AWG4/0 LV320 P10/95 LV320 P10/70 LV320 P10/50 ---	---	---	2x for charging plug/vehicle plug AWG 4/0 2x for charging plug/vehicle plug 95 mm <sup>2</sup> 2x for charging plug/vehicle plug AWG 3/0 2x for charging plug/vehicle plug AWG 1/0 2x for charging plug/vehicle plug AWG 4
---	Reducer	70/50 (AWG 3/0 to 1/0) 50/35 (AWG 1/0 to 1) 50/25 (AWG 1/0 to 3) 25/16 (AWG 4 to 5)	LV RH70/50 LV RH50/35 ---	---	---	Reducing AWG 3/0 down to AWG 1/0 Reducing AWG 1/0 down to AWG 1 Reducing AWG 1/0 down to AWG 4 Reducing AWG 4 down to AWG 5



Item	Designation		Ordering code			Description
			LV320/400	LV160/250	LV80/120	
8	<b>Aux. contacts</b>	Socket AWG 13 (2.5 mm <sup>2</sup> )	LV320 BCC-2.5-Ag	LV160 BBC-2.5-Ag	LV80 BBC-2.5-Ag	2x auxiliary contact for battery receptacle
9		Pin AWG 13 (2.5 mm <sup>2</sup> )	LV320 SCC-2.5-Ag	LV160 SBC-2.5-Ag	LV80 SBC-2.5-Ag	2x aux. contact for charging plug/vehicle plug
10a	<b>Pilot contact adapter</b>	Receptacle	LV160/320 PA-S		LV80 PA-S	Adapter for pilot contacts, sockets
10b		Plug	LV160/320 PA-P		LV80 PA-P	Adapter for pilot contacts, pins
11	<b>Pilot contacts</b>	Socket AWG 13 (2.5 mm <sup>2</sup> )	BCC-2.5-Ag		LV80 BBC-2.5-Ag	2x pilot contact for battery receptacle
12		Pin AWG 13 (2.5 mm <sup>2</sup> )	SCC-2.5-Ag		LV80 SBC-2.5-Ag	2x pilot contact for charging plug/vehicle plug
13	<b>Pilot contact set</b>	Adapter + socket contacts	LV160/320 P-S/S		LV80 P-S/S	Set, including items 10a, 11
14		Adapter + pin contacts	LV160/320 P-P/S		LV80 P-P/S	Set, including items 10b, 12
15a	<b>Air tube adapter</b>	for receptacle	LV160/320 LV-S		LV80 LV-S	for air tube with inside Ø 6 mm
15b	<b>Spacer</b>	for receptacle	LV160/320 DS-LS		LV80 DS-L	for securing air tube adapter (item 15a) in receptacle shell (item 1b)
15c	<b>Air tube adapter</b>	for plug	LV160/320 LV-P		LV80 LV-P	for air tube with inside Ø 6 mm
15d	<b>Spacer</b>	for plug	LV160/320 DS-LP		---	for securing air tube adapter (item 15c) in receptacle shell (item 1a)
---	<b>Connecting piece</b>	Extra air tube adapter	LV80/160/320 V-S 6/6			for tube diameter 6 mm
			LV80/160/320 V-S 6/10			for tube diameter 9...10 mm
16	<b>Handle</b>	Black, snap-on	LV160/320 H3		LV80 H1	Snap-on handle for receptacle /
		Red, snap-on	LV160/320 H4		LV80 H2	plug shell
		Black, screw-on	LV160/320 H1/S		LV80 H1/S	Screw-on handle for receptacle/
		Red, screw-on	LV160/320 H2/S		LV80 H2/S	plug shell, including screws

## Ordering of spare parts

SCHALTBAU GmbH is not liable for damages resulting from the fact that the Crimping, Installation and Maintenance Instructions were not observed or were observed only partially, or that no original SCHALTBAU GmbH spare parts were used or that altered components were used respectively, or connector halves of different series were combined when using the electrolyte recirculation.

The air tube interfaces of the connector halves of the older LB-L series are **not** compatible with the air tube interfaces of connector halves of the LV series.

### NOTICE

Only use the designated spare parts of the device and charging connectors series!

# Schaltbau GmbH

For detailed information on our products and services visit our website – or give us a call!

Schaltbau GmbH  
Hollerithstrasse 5  
81829 Munich  
Germany



Phone +49 89 9 30 05-0  
Fax +49 89 9 30 05-350  
Internet [www.schaltbau.com](http://www.schaltbau.com)  
e-Mail [contact@schaltbau.de](mailto:contact@schaltbau.de)

with compliments:



The production facilities of Schaltbau GmbH have been IRIS certified since 2008.



Certified to DIN EN ISO 14001 since 2002. For the most recent certificate visit our website.



Certified to DIN EN ISO 9001 since 1994. For the most recent certificate visit our website.

## Electrical Components and Systems for Railway Engineering and Industrial Applications

### Connectors

- Connectors manufactured to industry standards
- Connectors to suit the special requirements of communications engineering (MIL connectors)
- Charging connectors for battery-powered machines and systems
- Connectors for railway engineering, including UIC connectors
- Special connectors to suit customer requirements

### Snap-action switches

- Snap-action switches with positive opening operation
- Snap-action switches with self-cleaning contacts
- Snap-action switch made of robust polyetherimide (PEI)
- Snap-action switch with two galvanically isolated contact bridges
- Special switches to suit customer requirements

### Contactors Emergency disconnect switches

- Single and multi-pole DC contactors
- High-voltage AC/DC contactors
- Contactors for battery powered vehicles and power supplies
- Contactors for railway applications
- Terminal bolts and fuse holders
- DC emergency disconnect switches
- Special contactors to suit customer requirements

### Electrics for rolling stock

- Equipment for driver's cab
- Equipment for passenger use
- High-voltage switchgear
- High-voltage heaters
- High-voltage roof equipment
- Equipment for electric brakes
- Design and engineering of train electrics to customer requirements